

MeiKi明希®

MeiKi明希®
定制家具五金

定制家具五金



MeiKi明希®

生产基地 Production base

地址：四川省成都市天府新区邛崃产业园区羊纵一线 17 号
Add: No.17,Yangzong Yixian Qionglai Industrial Park,
Tianfu New Area,Chengdu,Sichuan,China.
Tel: 028-80256133
Wed: www.meikifittings.com



全国销售中心 National Sales Center

广东分公司 Guangdong Branch

地址：广东省佛山市南海区里水镇沙涌工业园
三星装饰工业有限公司内-明希五金
Add: Sanxing Decoration Industry Co., Ltd.--MeiKi Hardware,
Shayong Industrial Park, Lishui Town, Nanhai District,
Foshan City, Guangdong Province
Tel: 0757-85785666 0757-85705999

四川分公司 Sichuan Branch

地址：四川省成都市双流区东升西航港大道北段 333 号
Add: No. 333, North Section of Xihanggang Avenue,
Dongsheng, Shuangliu District, Chengdu, Sichuan
Tel: 028-85018999

为全屋定制家具企业提供完整专业的解决方案
Provide complete and professional solutions for whole-house customized furniture enterprises

Product Manual
SINCE 1994



Connect to
the world
in minutes
/

锁紧分秒间
连接全世界



SMALL BODY TIGHTLY CLOSED

小小身躯 亲密无间

三合一连接件的优点如下:

- 预埋螺母: 加固专用; 连接杆: 连接专用; 偏心头: 解决了板材之间锁紧问题。通过、涨栓, 螺栓, 偏心件组合的三合一连接, 牢固。
- 三合一连接可以多次拆装。这也是板式家具的优点之一。
- 隐蔽。从外表面看不到三合一连接件。
- 三合一连接, 减少了黏合剂的使用。更加环保。

The advantages of the three-in-one connector are as follows:

- Embedded nut: special for reinforcement; connecting rod: special for connection; eccentric head: solves the problem of locking between plates. The three-in-one connection of pass, expansion bolt, bolt and eccentric combination is firm.
- The three-in-one connection can be disassembled multiple times. This is also one of the advantages of panel furniture.
- Concealed. The three-in-one connector cannot be seen from the outer surface.
- Three-in-one connection reduces the use of adhesives. More environmentally friendly.



HISTORY OF CONNECTORS

连接件的历史

在家具生产过程中，板与板之间起到紧固和连接作用的部件，就是家具连接件，家具连接件中使用最多的是偏心连接件，因此，现代家具行业中家具连接件一般就是指偏心连接件。

中国传统家具原本不需要家具五金配件，所有功能的实现都是以木质结构为基础，金属在古代只作为一种装饰应用在家具中，直至清明时期，金属才在家具实现了简单的功能。板材家具和目前国外采用的“偏心连接件”的名称自 80 年代传入中国，家具五金配件才开始在家具中大量使用。经过近30年的发展，家具五金配件在家具中的作用也越来越重要，人们对家具的品质关注也开始从板材、环保慢慢转向了五金配件。随着近年来家具现代化、个性化的发展步伐，人们家具的需求也已经从最原始的收纳功能慢慢转向对精致生活的体验需求，而这些这种体验就直接感受自家具五金配件，因此，在未来一段时间内，家具五金配件将成为家具整体品质的最关键因素。

人们就以配件的数量取名:三合一连接件，还有二合一、四合一及其他的连接件，因为三合一这种类型用的最为普遍，所以在国内三合一连接件就成了偏心连接件的代称。三合一连接件主要用于板式家具的连接件，三合一由三部分组成:三合一相当于传统木工里的钉子和槽隼结构。分别是偏心头（又名偏心螺母、偏心轮、偏心件等等）、连接杆（螺栓）、预埋螺母（涨栓、塑料的俗称塑胶粒）三部分。

明希一直致力于用心筑就美好的家居生活，让五金连接件如何与家具的设计、生产、安装等环节实现无缝嫁接，规范家具五金连接件的应用，蕴含着深邃的产业文化，努力填补家具连接件技术领域的空白。

In the furniture production process, the parts that play the role of fastening and connecting between the board and the board are the furniture connectors. The most commonly used furniture connectors are the eccentric connectors. Therefore, the furniture connectors in the modern furniture industry generally refer to Eccentric connector.

Traditional Chinese furniture originally did not require furniture hardware accessories. All functions are realized based on wooden structures. Metal was only used as a decoration in furniture in ancient times. It was not until the Qingming period that metal realized simple functions in furniture. Panel furniture and the name "eccentric connector" currently used abroad have been introduced to China since the 1980s, and furniture hardware accessories have only begun to be widely used in furniture. After nearly 30 years of development, the role of furniture hardware accessories in furniture has become more and more important, and people's attention to the quality of furniture has gradually shifted from sheet metal and environmental protection to hardware accessories. With the development of modernization and personalization of furniture in recent years, people's needs for furniture have gradually shifted from the most primitive storage function to the demand for exquisite life experience, and these experiences are directly felt from furniture hardware accessories. Therefore, in the future, furniture hardware accessories will become the most critical factor in the overall quality of furniture.

People named it after the number of accessories: three-in-one connectors, as well as two-in-one, four-in-one and other connectors. Because the three-in-one type is the most common type, it is a three-in-one connector in China. It became a synonym for eccentric connector, The three-in-one connector is mainly used for the connector of panel furniture. The three-in-one is composed of three parts: the three-in-one is equivalent to the nail and groove structure in traditional woodworking. There are three parts: eccentric head (also known as eccentric nut, eccentric wheel, eccentric piece, etc.), connecting rod (bolt), and embedded nut (expanding bolt, commonly known as plastic pellets).

MeiKi has always been committed to building a beautiful home life with heart, so that how hardware connectors can be seamlessly integrated with furniture design, production, installation and other links, and standardizing the application of furniture hardware connectors, contains profound industrial culture, and strives to fill The gap in the field of furniture connector technology.

为家居提供环保整体解决方案

Provide an overall environmental protection solution for the home

MeiKi 明希, 专注于家具五金行业

二十五年来, 从未满足于过去的点滴成就

从一家生产家具五金企业迈向高端家具五金定制专家之路

我们勇于担当重任, 敢于接受考验。

MeiKi , specializing in furniture hardware industry

Twenty-five years, never resting on our laurels

From a production of furniture hardware enterprises to high-end furniture hardware customization experts

We dare to take responsibility, dare to be tested.

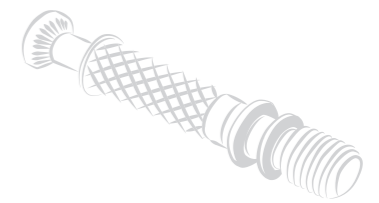

MEIKI PRODUCTION BASE

明希生产基地

SINCE 1994
10,000 m²

MeiKi 明希源于日本明希株式会社, 拥有 10 万平方米的现代化生产基地, 是集研发、制造、销售为一体的智能家居五金企业。

MeiKi originates from Japan's Meiki Co., Ltd., and has a modern production base of 100,000 square meters. It is a smart home hardware enterprise integrating R&D, manufacturing and sales.





Professional technology/Precision
manufacturing
专业技术/精工制造

Modern Production Equipment 一流的现代化生产设备

MeiKi明希斥巨资引进国内外一线品牌冷墩机、合模机、搓牙机、螺母机、注塑机、压铸机以及全自动攻牙机、光学智能筛选机、组装机等生产设备。设有冷墩线材改制、标准件、压铸、注塑四个制造事业部，以及自动化包装车间、标准化现代仓储物流配送中心。

专业为中高端定制家居提供智能、环保的系统性五金配件和解决方案。

MeiKi has invested heavily in the introduction of domestic and foreign first-line brand cold heading machines, mold clamping machines, threading machine, nut machines, injection molding machines, die casting machines and automatic tapping machines, optical intelligent screening machines, assembly machines and other production equipment. It has four manufacturing divisions of cold-rolled wire, standard parts, die-casting and injection molding, as well as an automated packaging workshop and a standardized modern warehouse logistics distribution center.

Professional to provide intelligent, environmentally friendly system hardware accessories and solutions for high-end custom homes.



◀ 高线盘圆 High-line coil



◀ 线材改制拉丝机 Wire Reforming Drawing Machine



◀ 热室压铸机 Hot chamber die casting machine



◀ 模具车间 Mold workshop



◀ 线材改制拉丝机 Wire Reforming Drawing Machine



◀ 多工位冷墩机 Multi-station Cold Heading machine



◀ 立式注塑机 Vertical injection molding machine



◀ 卧式注塑机 Horizontal injection molding machine



◀ 搓牙机 Threading Machine



◀ 光学智能筛选机 Optical intelligent screening machine

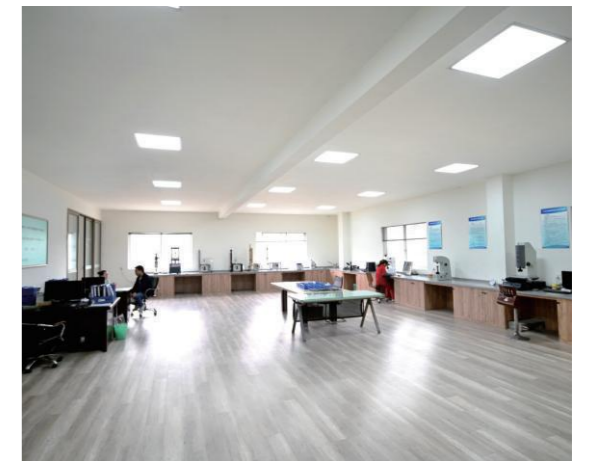

◀ 实验室 Laboratory



◀ 螺母机 Nut Machine



◀ 合模机 Mold clamping machine

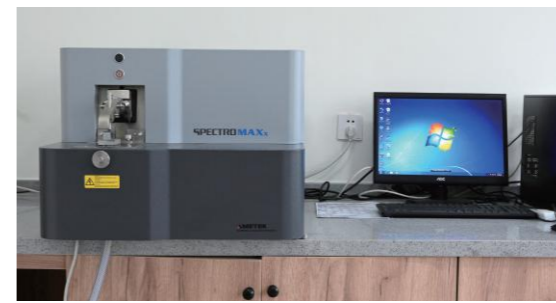

◀ 光谱仪 Spectrograph



◀ 程式恒温恒湿试验箱
Programmable Constant
Temperature And
Humidity Test Chamber



◀ 自动包装机
Automatic packaging
machine



Strong research and development team

强大的技术研发团队

MeiKi明希现有员工200多名,其中高素质管理团队10余人,研发技术骨干30余人,品质管控20余人,拥有高水平的研发能力,以特色开发为核心,自主设计产品已达500余种。生产管理严格按照汽车行业IATF16949标准要求,荣获CE认证、质量管理体系ISO9001认证、环境管理体系IS14001认证、职业健康管理体系OHSAS18001认证、SGS 通标标准技术服务检测。

MeiKi has more than 200 employees, including more than 10 high-quality management teams, more than 30 technical and technical backbones, more than 20 quality control personnel, and a high level of research and development capabilities. With its characteristic development as its core, its own design products have reached more than 500 kinds. Production management is strictly in accordance with the requirements of the automotive industry IATF16949 standard, and has been awarded CE certification, ISO9001 certification for quality management system, ISO14001 certification for environmental management system, OHSAS18001 certification for occupational health management system, and technical service testing for SGS standard.

Our source
of
power
我们的源动力

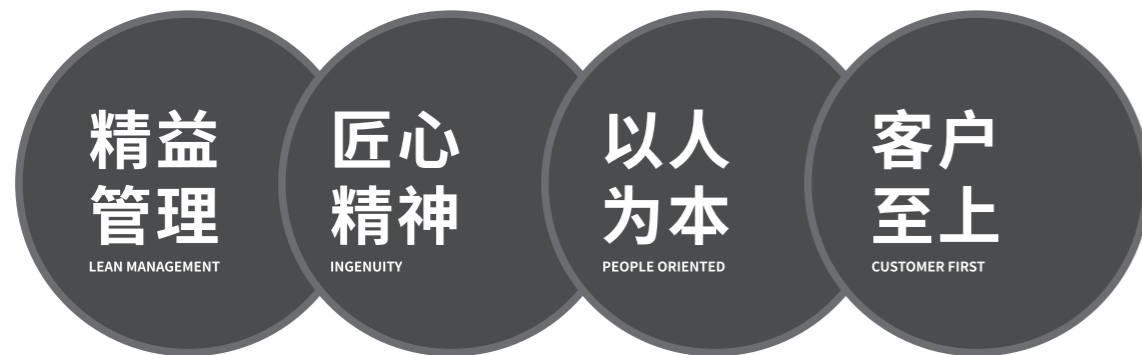

精益管理打造百年企业 匠心精神传承企业文化

MeiKi明希不忘初心、创新进取、砥砺前行，秉持精工制造、品质卓越、以人为本、客户至上的经营理念，以开放式的战略合作模式，通过持续创新为客户创造价值，与合作伙伴、行业组织、高校、研究机构等构建共赢生态圈，加大研发投入，提高产品质量管控，厚积薄发，推动技术进步和企业发展。

MeiKi明希怀揣梦想和荣耀，以领军定制家具五金配件行业的雄心，向着国内市场领跑者和全球主流供应商的企业目标迈进。

MeiKi has not forgotten its original intentions, innovation and progress, and is committed to the business philosophy of precision manufacturing, quality, people-oriented and customer first. With an open strategic cooperation model, we create value for our customers through continuous innovation, with partners and industry organizations, Universities, research institutions, etc. to build a win-win ecosystem, increase investment in research and development, improve product quality control, accumulate and promote technological progress and enterprise development.

With its ambition to lead the custom furniture hardware accessories industry, MeiKi is marching towards the corporate goals of the domestic market leader and the global mainstream suppliers.





The creator of the design 设计创造者

回归生活本源是设计的灵魂。好的设计，不在乎它有多复杂有多华丽，最完美的设计，往往是最量身定制的设计。明希是设计的创造者，它的设计使每一款螺丝都仿似一件会呼吸的作品，它融入了到你的生活家具空间，你的生活方式，与你同步呼吸一样的空气。

Returning to the origin of life is the soul of design. Good design, do not care how complex and gorgeous it is, the most perfect design, often the most customized design. MeiKi is the creator of the design, it is designed so that each screw is like a piece of work that can breathe, it is integrated into your life furniture space, your lifestyle, and you synchronize the same air.

Peak quality glory witness

巅峰品质/荣耀见证

Enterprise certification
企业认证



Enterprise certification
企业认证



Utility model
Patent certificate
实用新型
专利证书



一种板材连接卡扣 (实用新型专利证书) 一种角度可调的板式家具
隐形连接件(实用新型专利证书) 一种家具用膨胀螺栓
(实用新型专利证书) 一种包装自动接驳机构
(实用新型专利证书) 一种零件与料枝自动分离机构
(实用新型专利证书)



一种嵌入式隐形连接件
(实用新型专利证书) 一种快装锁紧隐形连接件
(实用新型专利证书) 一种快装锁紧连接件
(实用新型专利证书) 一种板材连接结构
(实用新型专利证书) 一种增强承重能力的层板连接结构
(实用新型专利证书)



一种膨胀螺栓 (实用新型专利证书) 隐形连接件
(实用新型专利证书) 隐形层板连接件
(实用新型专利证书) 一种嵌入式翻板连接件
(实用新型专利证书) 一种偏心驱动的板体连接件
(实用新型专利证书) 一种板体的滑入式连接结构
(实用新型专利证书)



一种膨胀连接件
(实用新型专利证书) 一种便于层板拆装的层板连接件
(实用新型专利证书) 一种隐藏式双头膨胀连接件
(实用新型专利证书) 一种快速装入家具板材及门框的
隐形连接杆(实用新型专利证书) 一种双头锁紧的隐藏式连接件
(实用新型专利证书) 弹性层板托
(实用新型专利证书)

Appearance design
Patent certificate
外观设计
专利证书



板件连接卡扣 (外观设计专利证书) 反弹器
(外观设计专利证书) 反弹器
(外观设计专利证书) WG-HG2022013 螺杆
(外观设计专利证书)



HG2022011 螺杆
(外观设计专利证书) 隐形层板连接件
(外观设计专利证书) WG-HG2022010 装饰盖
(外观设计专利证书) 螺旋隐形连接件
(外观设计专利证书) 带边偏心轮
(外观设计专利证书) 带盖偏心轮
(外观设计专利证书)



为家居提供
环保整体解决方案
Provide an overall
environmental protection solution
for the home

Meiki明希[®]

定制家具五金

CONTENT

目录

Connecting fitting series 拆装连接件系列

001

Eccentric cam series
偏心轮系列

015

Connecting bolt series
连接杆系列

041

Strong connector series
强力连接件系列

047

Bolt and decorative screw series
螺杆装饰螺丝系列

055

Shelf support screw series
板托螺丝系列

061

Decorative cover of eccentric cam series
偏心轮装饰盖系列

067

Embedded part series
预埋件系列

Shelf supports series 层板连接件系列

083

Shelf supports series
层板连接件系列

101

Glass clip series
玻璃夹系列

Wardrobe tube support series 衣管座系列

111

Wardrobe tube support series
衣管座系列

Push open system series 反弹器系列

119

Push open system series
反弹器系列

Cabinet hanger series 挂码系列

125

Cabinet hanger series
挂码系列

Gas support series 支撑系列

129

Gas support series
支撑系列

Adjustable foot series 可调脚系列

143

Adjustable foot series
可调脚系列

Slide series 滑轨系列

179

Slide series
滑轨系列

Push open system series 反弹器系列

189

Metalbox runners series
骑马抽系列

Hinge series 铰链系列

197

Hinge series
铰链系列

Lock series 锁具系列

231

Lock series
锁具系列

Accessory series 小件系列

237

Accessory series
小件系列

247

Lazy susan turntable series
转盘系列

150-170°最佳锁紧状态 Optimum locking condition

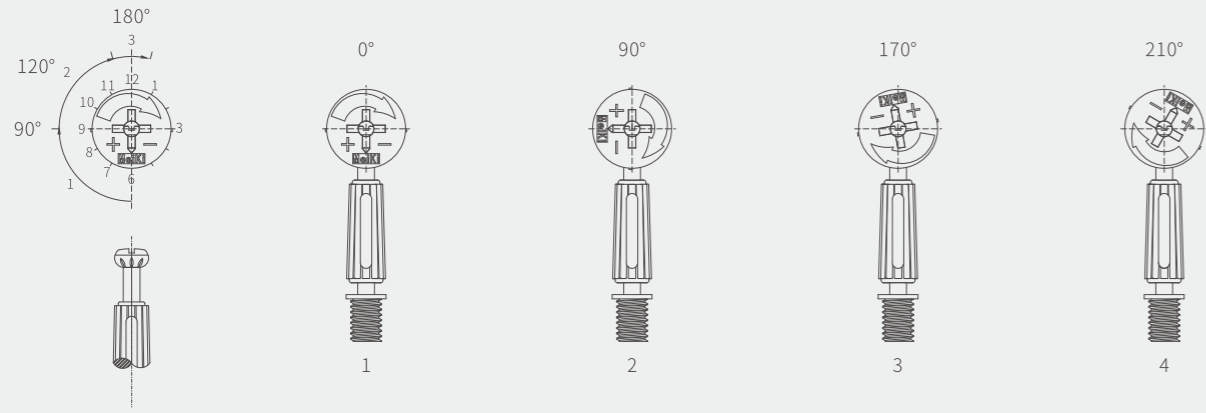

偏心轮锁紧行程可以分三个阶段

The Cam locking stroke can be divided into three stages:

1. 装配阶段
0°安装时便于安装拆卸连接件。
2. 紧固阶段
0°-170°转动偏心轮开始锁紧, 偏心轮一般从100°开始受力进入锁紧状态, 最佳紧固状态为150°-170°
3. 过度锁防退加固
170°-190°
该阶段仅在如下特殊情况发生
(1) 钻孔尺寸偏差、(2) 家具反复拆装、(3) 由于过负荷要求过度加固

1. Assembly stage
0° mounting facilitates installation and removal of connecting parts.
2. Tightening stage
0°-170° rotation of the cam to start locking, the cam is generally from 100° to start the force into the locking state, the best tightening state is 150°-170°.
3. Excessive locking anti-return reinforcement
170°-190°
This stage only occurs in the following special circumstances
(1) Deviation of drilling size, (2) Repeated disassembly and assembly of furniture, (3) Over-reinforcement due to overload.

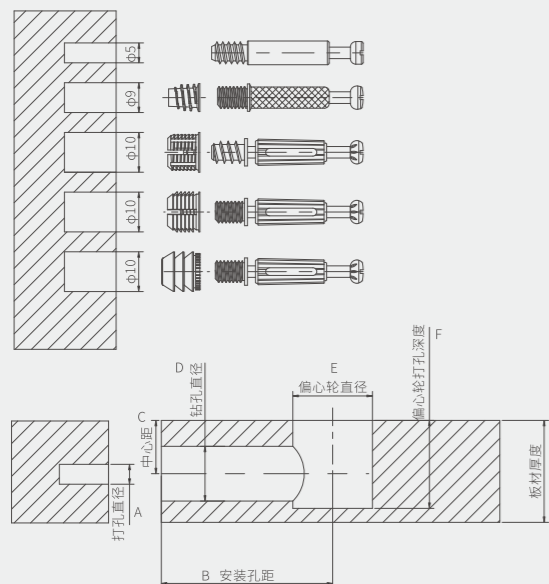
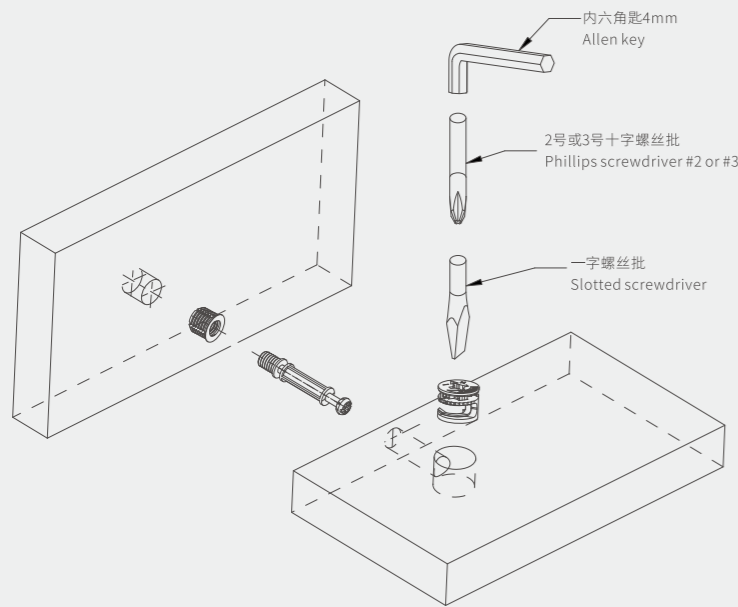

打孔直径A: 按连接杆自攻牙径、预埋件外径要求钻孔;
安装孔距B: 按连接杆安装尺寸选择标准钻孔距离, 详见连接杆页面;
中心距C: 根据板材厚度进行开孔;
钻孔直径D: 按连接杆外径选择打孔直径;
偏心轮直径E: 按偏心轮直径钻孔, 详见偏心轮页面;
偏心轮打孔深度F: 根据偏心轮不同高度、中心距和不同板材的厚度开孔详见偏心轮页面。

Drilling diameter A: According to the connecting bolt self-tapping teeth diameter, embedded parts outer diameter requirements drilling;
Installation hole distance B: According to the connecting bolt installation size selection of standard drilling distance, see connecting bolt page for details;
Center distance C: According to the thickness of the plate to open the hole;
Drilling Diameter D: Select the drilling diameter according to the outer diameter of the connecting bolt;
Eccentric cam diameter E: Drill holes according to the diameter of the eccentric cam, see the page on eccentric cam;
Eccentric cam drilling depth F: Drilling holes according to different heights of the eccentric cam, center distance, and thickness of different plates, see the page on the eccentric wheel.

三合一连接方式主要分直角连接和平面连接、三板交互连接三种方式
Three-in-one connection methods are mainly divided into right-angle connection, plane connection, and three-plate interactive connection.

平面连接 Plane connection

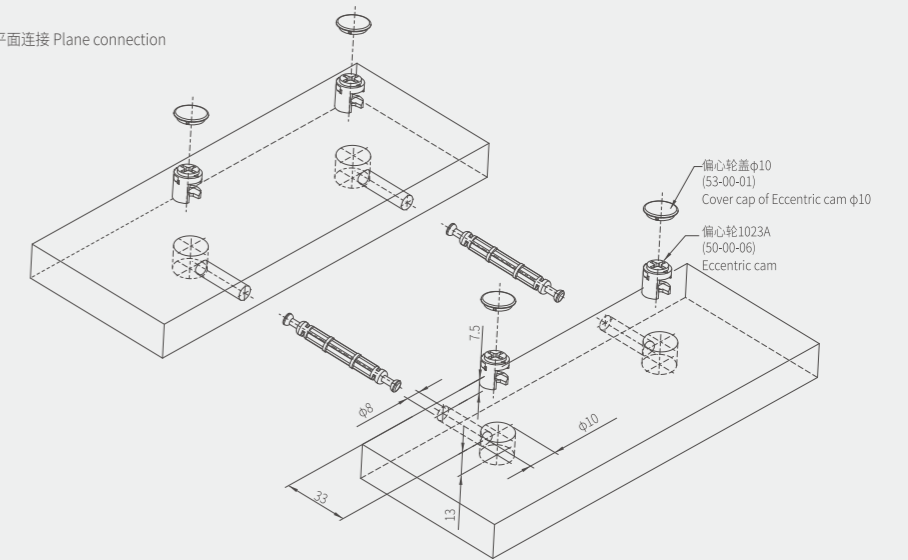

三板交互连接 Three-plate interactive connection

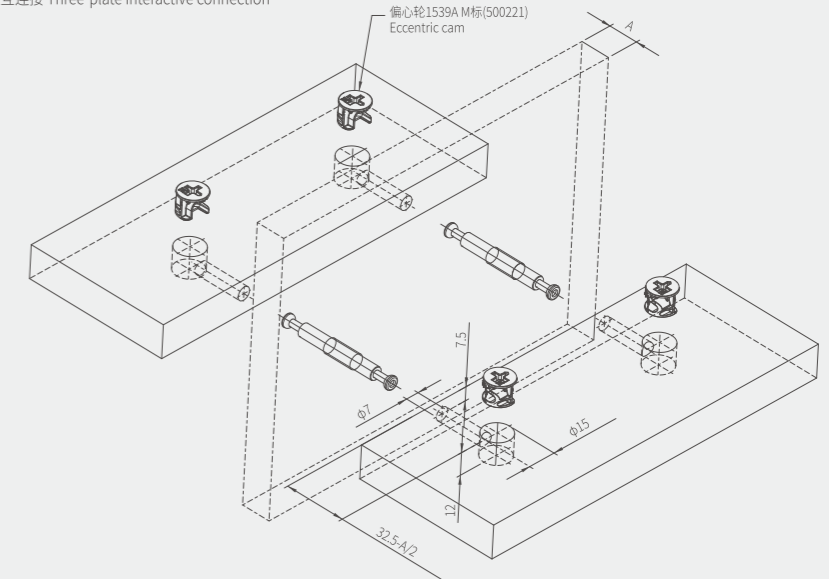

直角连接 Right-angled connection

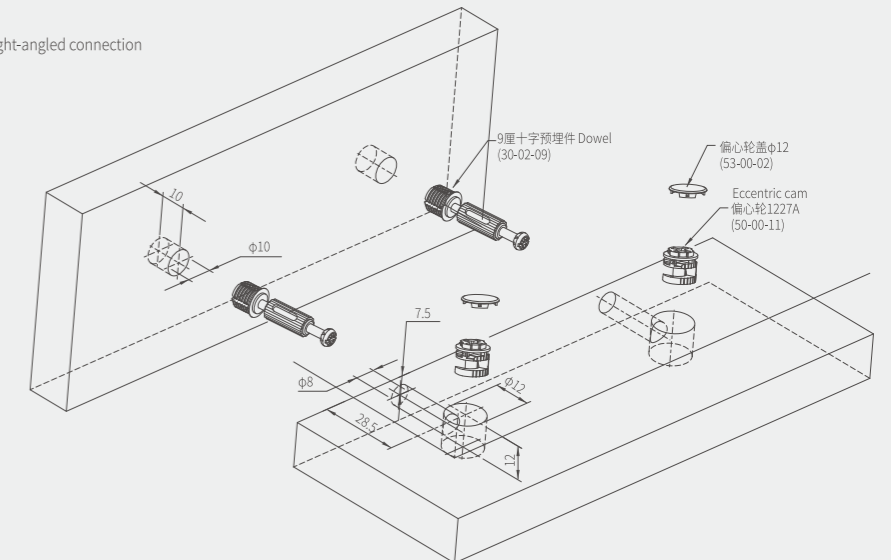

MeiKi明希®

ECCENTRIC CAM SERIES
偏心轮系列



DURABLE AND LONG-LASTING
坚固耐用 历久弥新

小巧精致, 质感出色
咬合紧密, 不易滑牙或松动
Small and delicate, excellent quality
Tight bite, not easy to slip or loose teeth



Meiki明希®

DURABLE AND LONG-LASTING
坚固耐用 历久弥新

小巧精致, 质感出色
咬合紧密, 不易滑牙或松动
Small and delicate, excellent quality
Tight bite, not easy to slip or loose teeth

MKCAM-ZA-50-00-06 锌合金偏心轮 MKCAM-ZA-50-00-06 Zinc alloy eccentric cam



订货号 Item number	MKCAM-ZA-50-00-06
适用板材 Applicable panel	≥15mm
中心距离 Central distance	6.7mm
产品材质 Material	锌合金 Zinc alloy
颜色可选 Finish	蓝白锌 Blue zinc, 镍 Nickel plating, 枪色 Gun-black
可选装饰盖 Optional decorative cover	2# 10锌合金盖 2# 10 Zinc alloy cover 4# 10下沉式塑料盖 4# 10 Countersunk plastic cover

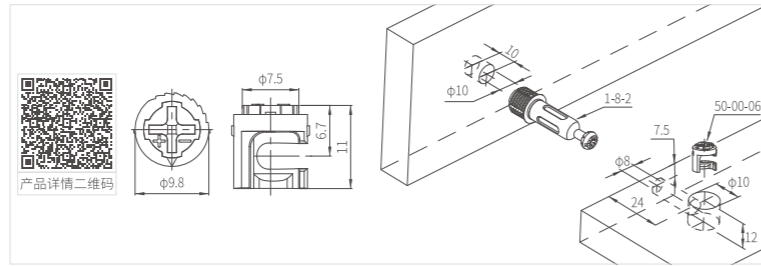

MKCAM-ZA-50-42-05 锌合金偏心轮 MKCAM-ZA-50-42-05 Zinc alloy eccentric cam



订货号 Item number	MKCAM-ZA-50-42-05
适用板材 Applicable panel	≥12mm
中心距离 Central distance	5.8mm
产品材质 Material	锌合金 Zinc alloy
颜色可选 Finish	蓝白锌 Blue zinc, 镍 Nickel plating, 枪色 Gun-black
可选装饰盖 Optional decorative cover	7# 12塑料盖 7# 12 Plastic cover

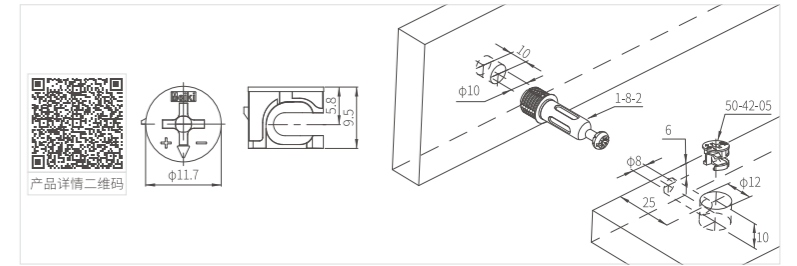

MKCAM-ZA-50-00-11 锌合金偏心轮 MKCAM-ZA-50-00-11 Zinc alloy eccentric cam

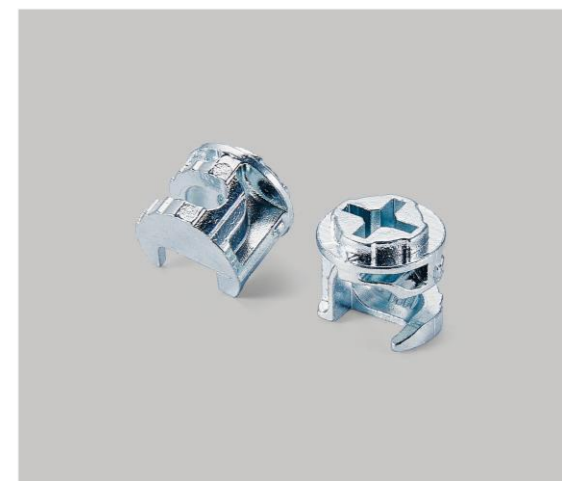

订货号 Item number	MKCAM-ZA-50-00-11
适用板材 Applicable panel	≥15mm
中心距离 Central distance	7.0mm
产品材质 Material	锌合金 Zinc alloy
颜色可选 Finish	蓝白锌 Blue zinc, 镍 Nickel plating, 枪色 Gun-black
可选装饰盖 Optional decorative cover	1# 12锌合金盖 1# 12 Zinc alloy cover 3# 12下沉式塑料盖 3# 12 Countersunk plastic cover

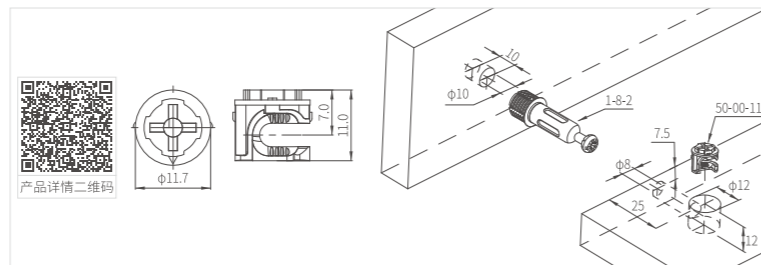

MKCAM-ZA-50-00-03 锌合金偏心轮 MKCAM-ZA-50-00-03 Zinc alloy eccentric cam



订货号 Item number	MKCAM-ZA-50-00-03
适用板材 Applicable panel	≥15mm
中心距离 Central distance	7.3mm
产品材质 Material	锌合金 Zinc alloy
颜色可选 Finish	蓝白锌 Blue zinc, 镍 Nickel plating, 枪色 Gun-black
可选装饰盖 Optional decorative cover	7# 12塑料盖 7# 12 Plastic cover

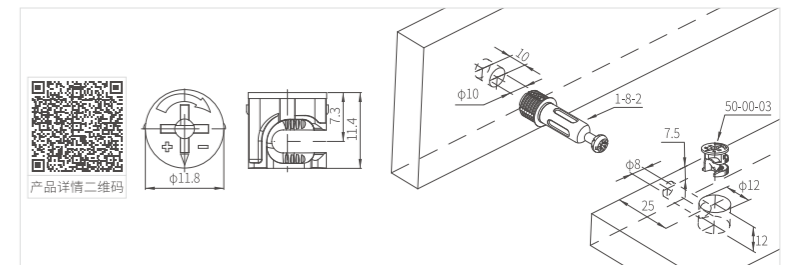

MKCAM-ZA-50-00-02 锌合金偏心轮 MKCAM-ZA-50-00-02 Zinc alloy eccentric cam



订货号 Item number	MKCAM-ZA-50-00-02
适用板材 Applicable panel	≥15mm
中心距离 Central distance	6.7mm
产品材质 Material	锌合金 Zinc alloy
颜色可选 Finish	蓝白锌 Blue zinc, 镍 Nickel plating, 枪色 Gun-black
可选装饰盖 Optional decorative cover	1# 12锌合金盖 1# 12 Zinc alloy cover 3# 12下沉式塑料盖 3# 12 Countersunk plastic cover

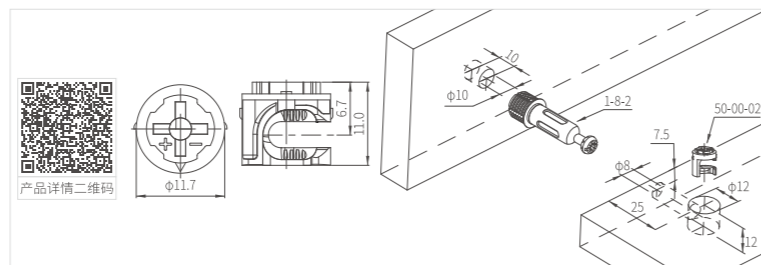

MKCAM-ZA-50-00-15 锌合金偏心轮 MKCAM-ZA-50-00-15 Zinc alloy eccentric cam



订货号 Item number	MKCAM-ZA-50-00-15
适用板材 Applicable panel	≥18mm
中心距离 Central distance	8.5mm
产品材质 Material	锌合金 Zinc alloy
颜色可选 Finish	蓝白锌 Blue zinc, 镍 Nickel plating, 枪色 Gun-black
可选装饰盖 Optional decorative cover	7# 12塑料盖 7# 12 Plastic cover

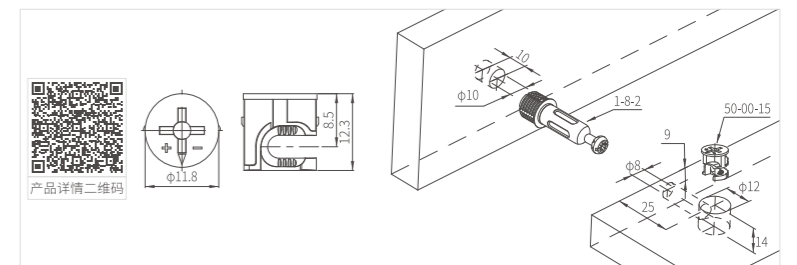

MKCAM-ZA-50-46-18 锌合金偏心轮 MKCAM-ZA-50-46-18 Zinc alloy eccentric cam



订货号 Item number	MKCAM-ZA-50-46-18
适用板材 Applicable panel	≥15mm
中心距离 Central distance	7.2mm
产品材质 Material	锌合金 Zinc alloy
颜色可选 Finish	蓝白锌 Blue zinc, 镍 Nickel plating, 枪色 Gun-black

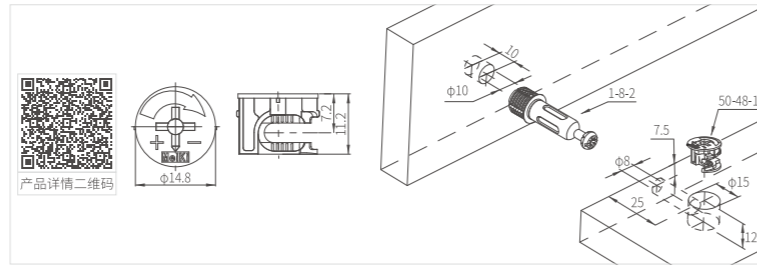

MKCAM-ZA-50-53-27 锌合金偏心轮 MKCAM-ZA-50-53-27 Zinc alloy eccentric cam



订货号 Item number	MKCAM-ZA-50-53-27
适用板材 Applicable panel	≥18mm
中心距离 Central distance	8.7mm
产品材质 Material	锌合金 Zinc alloy
颜色可选 Finish	蓝白锌 Blue zinc, 镍 Nickel plating, 枪色 Gun-black

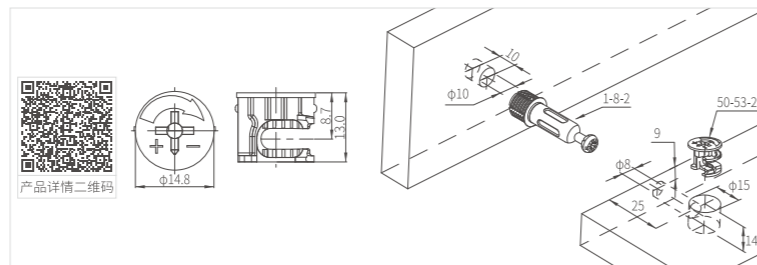

MKCAM-ZA-50-46-23 锌合金偏心轮 MKCAM-ZA-50-46-23 Zinc alloy eccentric cam



订货号 Item number	MKCAM-ZA-50-46-23
适用板材 Applicable panel	≥15mm
中心距离 Central distance	7.45mm
产品材质 Material	锌合金 Zinc alloy
颜色可选 Finish	蓝白锌 Blue zinc, 镍 Nickel plating, 枪色 Gun-black

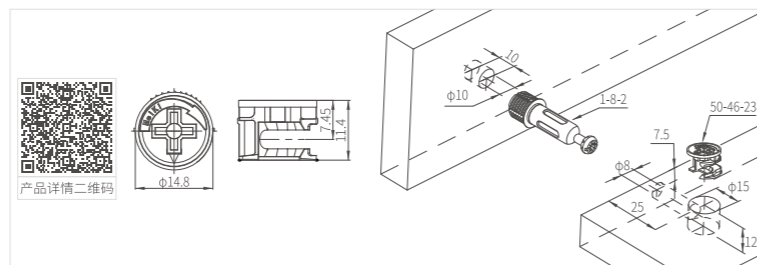

MKCAM-ZA-50-26-22 锌合金偏心轮 MKCAM-ZA-50-26-22 Zinc alloy eccentric cam



订货号 Item number	MKCAM-ZA-50-26-22
适用板材 Applicable panel	≥15mm
中心距离 Central distance	7.4mm
产品材质 Material	锌合金 Zinc alloy
颜色可选 Finish	蓝白锌 Blue zinc, 镍 Nickel plating, 枪色 Gun-black

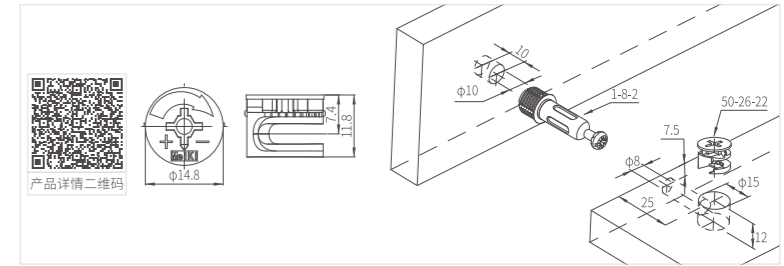

MKCAM-ZA-50-28-22 锌合金偏心轮 MKCAM-ZA-50-28-22 Zinc alloy eccentric cam



订货号 Item number	MKCAM-ZA-50-28-22
适用板材 Applicable panel	≥18mm
中心距离 Central distance	8.8mm
产品材质 Material	锌合金 Zinc alloy
颜色可选 Finish	蓝白锌 Blue zinc, 镍 Nickel plating, 枪色 Gun-black

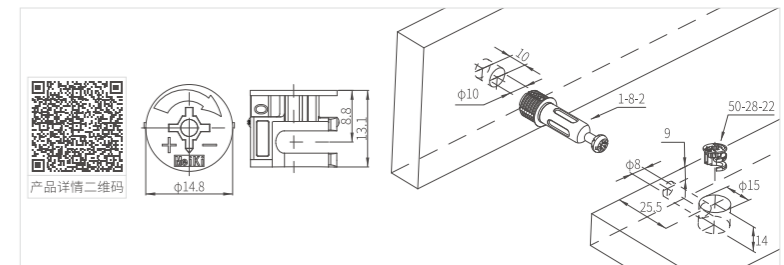

MKCAM-ZA-50-13-31 锌合金偏心轮 MKCAM-ZA-50-13-31 Zinc alloy eccentric cam



订货号 Item number	MKCAM-ZA-50-13-31
适用板材 Applicable panel	≥18mm
中心距离 Central distance	8.1mm
产品材质 Material	锌合金 Zinc alloy
颜色可选 Finish	蓝白锌 Blue zinc, 镍 Nickel plating, 枪色 Gun-black

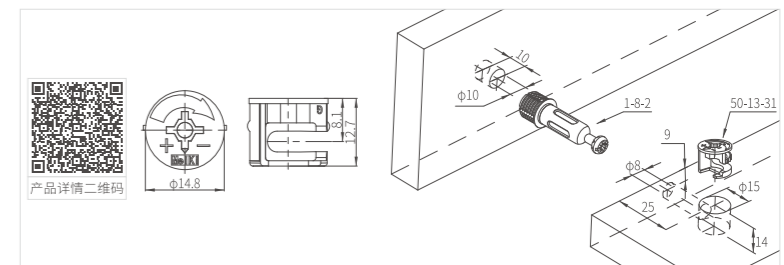

MKCAM-ZA-50-89-01 锌合金偏心轮 MKCAM-ZA-50-89-01 Zinc alloy eccentric cam



订货号 Item number	MKCAM-ZA-50-89-01
适用板材 Applicable panel	≥25mm
中心距离 Central distance	≥13.7mm
产品材质 Material	锌合金 Zinc alloy
颜色可选 Finish	蓝白锌 Blue zinc, 镍 Nickel plating

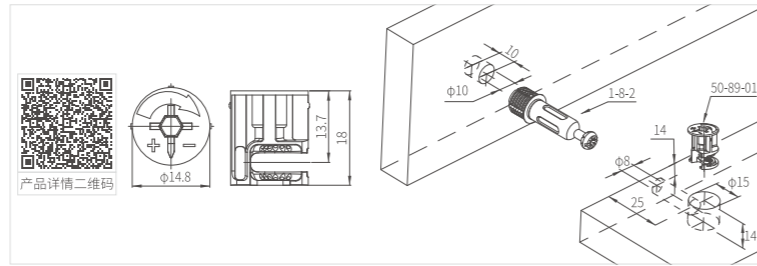

MKCAM-ZA-23-02-01 铁偏心轮 MKCAM-ZA-23-02-01 Iron eccentric cam

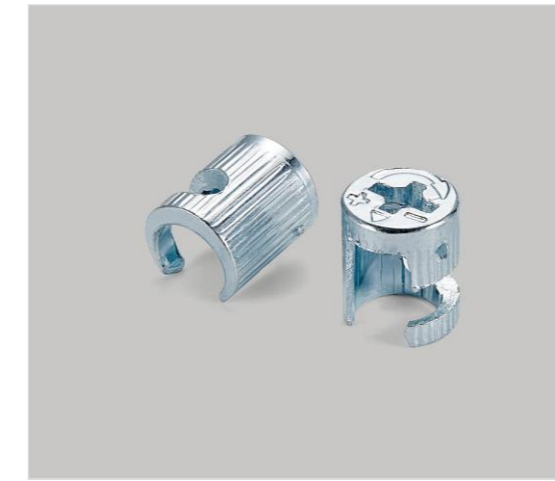

订货号 Item number	MKCAM-ZA-23-02-01
适用板材 Applicable panel	≥18mm
中心距离 Central distance	7.8mm
产品材质 Material	铁 Iron
颜色可选 Finish	蓝白锌 Blue zinc, 镍 Nickel plating, 枪色 Gun-black
可选装饰盖 Optional decorative cover	8# 10塑料盖 8# 10 Plastic cover

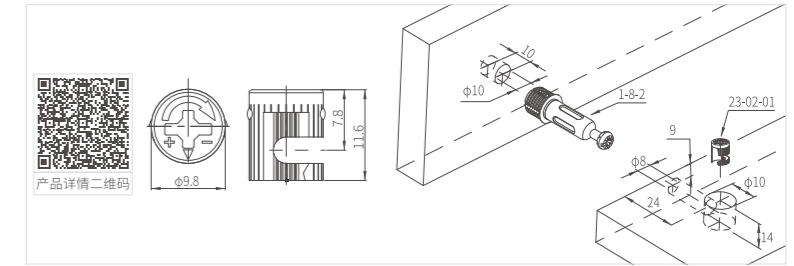

MKCAM-ZA-23-02-02 铁偏心轮 MKCAM-ZA-23-02-02 Iron eccentric cam



订货号 Item number	MKCAM-ZA-23-02-02
适用板材 Applicable panel	≥15mm
中心距离 Central distance	6.7mm
产品材质 Material	铁 Iron
颜色可选 Finish	蓝白锌 Blue zinc, 镍 Nickel plating, 枪色 Gun-black
可选装饰盖 Optional decorative cover	2# 10锌合金盖 2# 10 Zinc alloy cover 4# 10下沉式塑料盖 4# 10 Countersunk plastic cover

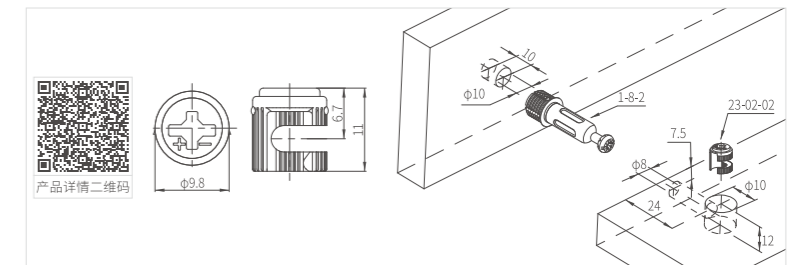

MKCAM-ZA-23-01-09 铁偏心轮 MKCAM-ZA-23-01-09 Iron eccentric cam



订货号 Item number	MKCAM-ZA-23-01-09
适用板材 Applicable panel	≥15mm
中心距离 Central distance	7.0mm
产品材质 Material	铁 Iron
颜色可选 Finish	蓝白锌 Blue zinc, 镍 Nickel plating, 枪色 Gun-black
可选装饰盖 Optional decorative cover	1# 12锌合金盖 1# 12 Zinc alloy cover 3# 12下沉式塑料盖 3# 12 Countersunk plastic cover

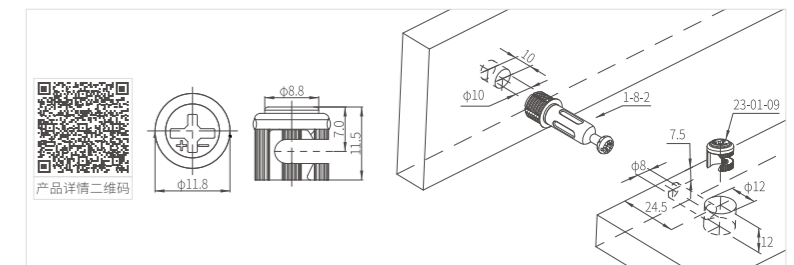

MKCAM-ZA-23-01-05 铁偏心轮 MKCAM-ZA-23-01-05 Iron eccentric cam



订货号 Item number	MKCAM-ZA-23-01-05
适用板材 Applicable panel	≥18mm
中心距离 Central distance	8.0mm
产品材质 Material	铁 Iron
颜色可选 Finish	蓝白锌 Blue zinc, 镍 Nickel plating, 枪色 Gun-black
可选装饰盖 Optional decorative cover	7# 12塑料盖 7# 12 Plastic cover

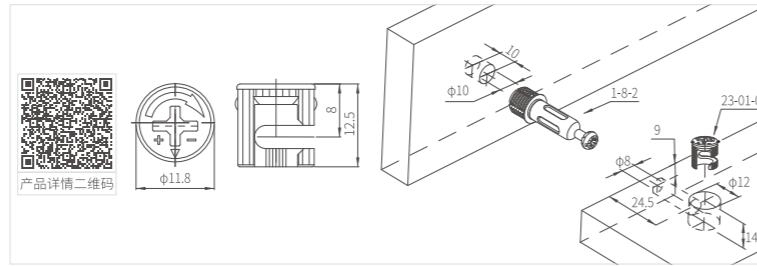

MKCAM-ZA-23-01-12 铁偏心轮 MKCAM-ZA-23-01-12 Iron eccentric cam



订货号 Item number	MKCAM-ZA-23-01-12
适用板材 Applicable panel	≥12mm
中心距离 Central distance	6.0mm
产品材质 Material	铁 Iron
颜色可选 Finish	蓝白锌 Blue zinc, 镍 Nickel plating, 枪色 Gun-black
可选装饰盖 Optional decorative cover	7# 12塑料盖 7# 12 Plastic cover

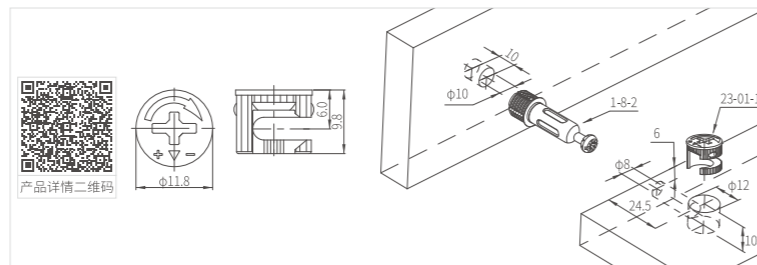

MKCAM-ZA-23-01-11 铁偏心轮 MKCAM-ZA-23-01-11 Iron eccentric cam



订货号 Item number	MKCAM-ZA-23-01-11
适用板材 Applicable panel	≥15mm
中心距离 Central distance	7.1mm
产品材质 Material	铁 Iron
颜色可选 Finish	蓝白锌 Blue zinc, 镍 Nickel plating, 枪色 Gun-black
可选装饰盖 Optional decorative cover	7# 12塑料盖 7# 12 Plastic cover

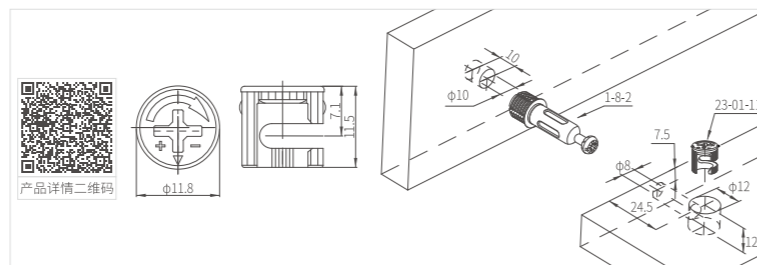

MKCAM-ZA-23-04-07 铁偏心轮 MKCAM-ZA-23-04-07 Iron eccentric cam



订货号 Item number	MKCAM-ZA-23-04-07
适用板材 Applicable panel	≥15mm
中心距离 Central distance	6.9mm
产品材质 Material	铁 Iron
颜色可选 Finish	蓝白锌 Blue zinc, 镍 Nickel plating, 枪色 Gun-black

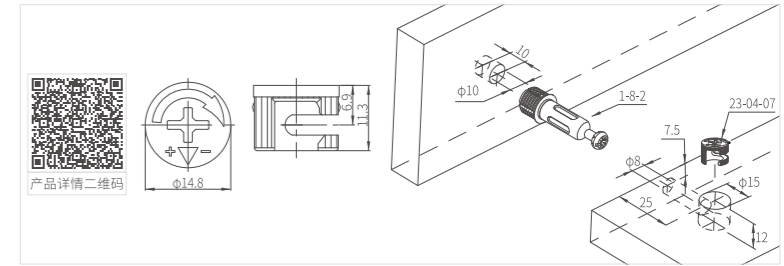

MKCAM-ZA-23-04-11 铁偏心轮 MKCAM-ZA-23-04-11 Iron eccentric cam



订货号 Item number	MKCAM-ZA-23-04-11
适用板材 Applicable panel	≥15mm
中心距离 Central distance	6.1mm
产品材质 Material	铁 Iron
颜色可选 Finish	蓝白锌 Blue zinc, 镍 Nickel plating, 枪色 Gun-black
可选装饰盖 Optional decorative cover	7# 12塑料盖 7# 12 Plastic cover

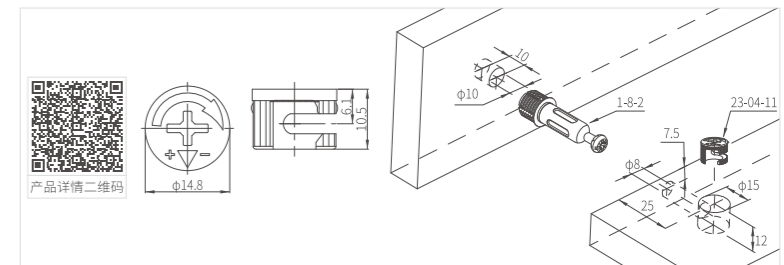

MKCAM-ZA-23-04-14 铁偏心轮 MKCAM-ZA-23-04-14 Iron eccentric cam



订货号 Item number	MKCAM-ZA-23-04-14
适用板材 Applicable panel	≥15mm
中心距离 Central distance	6.9mm
产品材质 Material	铁 Iron
颜色可选 Finish	蓝白锌 Blue zinc, 镍 Nickel plating, 枪色 Gun-black

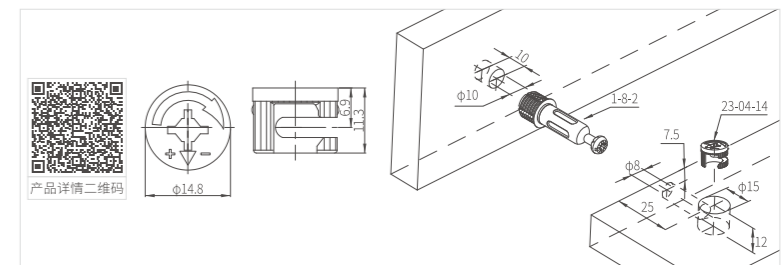

MeiKi明希®

CONNECTING BOLT SERIES
连接杆系列



FURNITURE SMOOTH YEARS QUIET GOOD
家具平稳 岁月静好

平稳连接每一件家具
连接生活的美好与宁静
Smoothly connect each piece of furniture
Connect the beauty and tranquility of life



MeiKi明希®

FURNITURE SMOOTH YEARS QUIET GOOD
家具平稳 岁月静好

平稳连接每一件家具
连接生活的美好与宁静
Smoothly connect each piece of furniture
Connect the beauty and tranquility of life

MK-JSG-6-5-1 多介金属杆 MK-JSG-6-5-1 Metal bolt



订货号 Item number	MK-JSG-6-5-1
安装尺寸 Installation size	33mm
产品材质 Material	碳钢 Carbon steel
表面处理 Finish	蓝白锌 Blue zinc

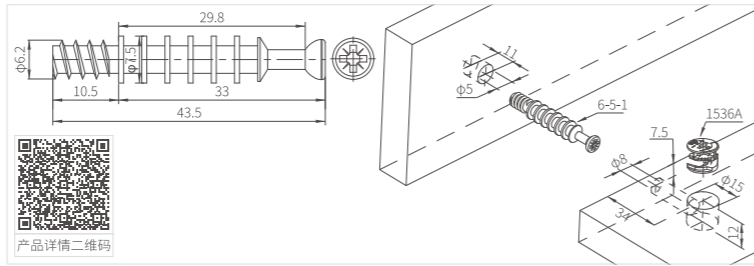

MK-JSG-6-5-2 多介金属杆 MK-JSG-6-5-2 Metal bolt



订货号 Item number	MK-JSG-6-5-2
安装尺寸 Installation size	33mm
产品材质 Material	碳钢 Carbon steel
表面处理 Finish	蓝白锌 Blue zinc

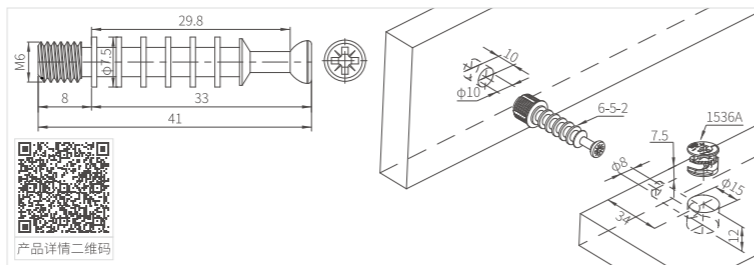

MK-JSG-6-7-4 多介金属杆 MK-JSG-6-7-4 Metal bolt



订货号 Item number	MK-JSG-6-7-4
安装尺寸 Installation size	33.5mm
产品材质 Material	碳钢 Carbon steel
表面处理 Finish	蓝白锌 Blue zinc

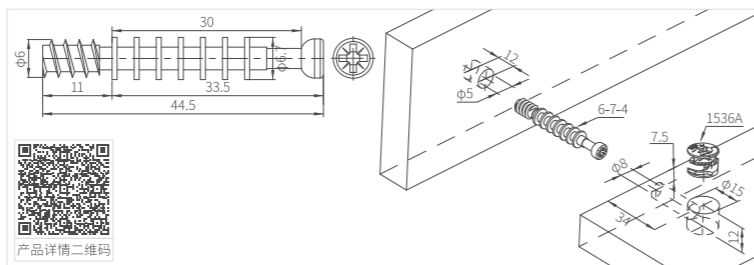

MK-JSG-9-7 金属自攻牙 MKJSG-9-7 Metal self-driven screw



订货号 Item number	MK-JSG-9-7
产品材质 Material	碳钢 Carbon steel
表面处理 Finish	蓝白锌 Blue zinc

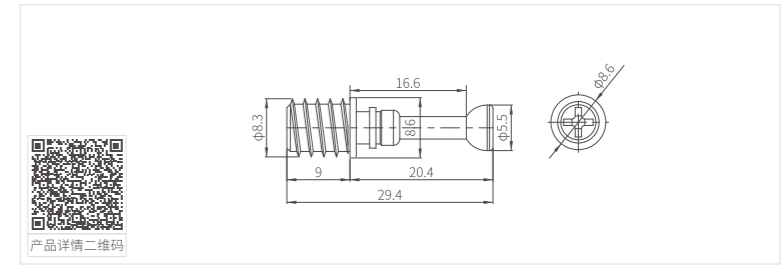

MK-JSG-4-20 金属竖纹杆 MK-JSG-4-20 Metal bolt with vertical grain

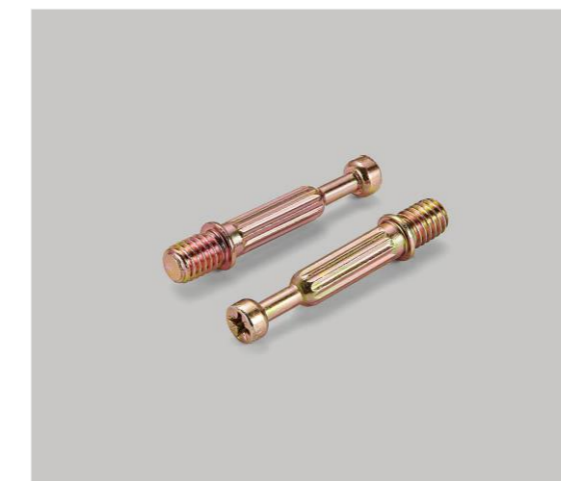

订货号 Item number	MK-JSG-4-20
安装尺寸 Installation size	30mm
产品材质 Material	碳钢 Carbon steel
表面处理 Finish	蓝白锌 Blue zinc, 彩锌 Colored zinc

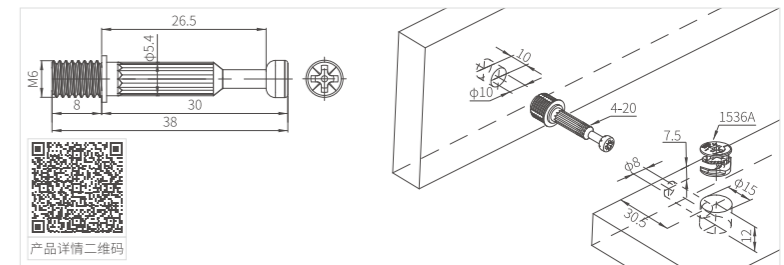

MK-JSG-4-22-1 金属竖纹杆 MK-JSG-4-22-1 Metal bolt with vertical grain



订货号 Item number	MK-JSG-4-22-1
安装尺寸 Installation size	29mm
产品材质 Material	碳钢 Carbon steel
表面处理 Finish	蓝白锌 Blue zinc

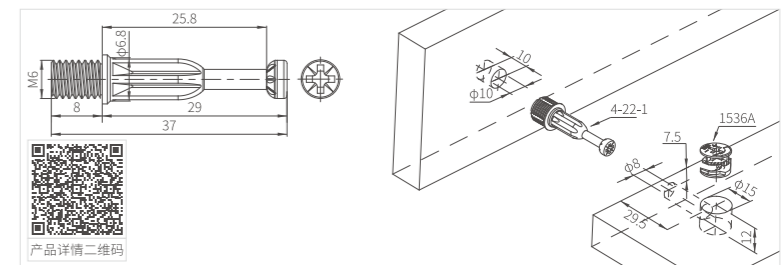

MK-GHG-6-7-8 金属双介滚花杆 MK-GHG-6-7-8 Metal bolt



订货号 Item number	MK-GHG-6-7-8
安装尺寸 Installation size	33.3mm
产品材质 Material	碳钢 Carbon steel
表面处理 Finish	蓝白锌 Blue zinc

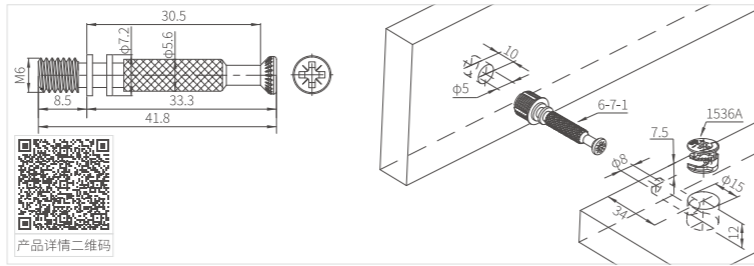

产品详情二维码

MK-GHG-6-7-9 金属双介滚花杆 MK-GHG-6-7-9 Metal bolt



订货号 Item number	MK-GHG-6-7-9
安装尺寸 Installation size	23.3mm
产品材质 Material	碳钢 Carbon steel
表面处理 Finish	蓝白锌 Blue zinc

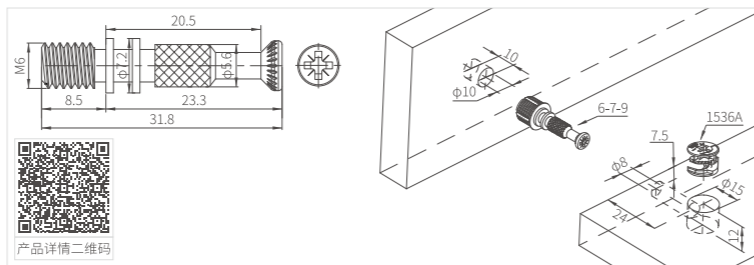

产品详情二维码

MK-GHG-6-7-10 金属双介滚花杆 MK-GHG-6-7-10 Metal bolt



订货号 Item number	MK-GHG-6-7-10
安装尺寸 Installation size	23.3mm
产品材质 Material	碳钢 Carbon steel
表面处理 Finish	蓝白锌 Blue zinc

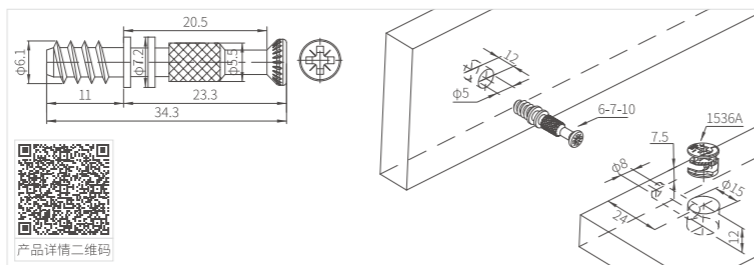

产品详情二维码

MK-SZ-3-10-7 金属双头折叠杆 MK-SZ-3-10-7 Double folded bolt



订货号 Item number	MK-SZ-3-10-7
产品材质 Material	铁 Iron
表面处理 Finish	彩锌 Colored zinc

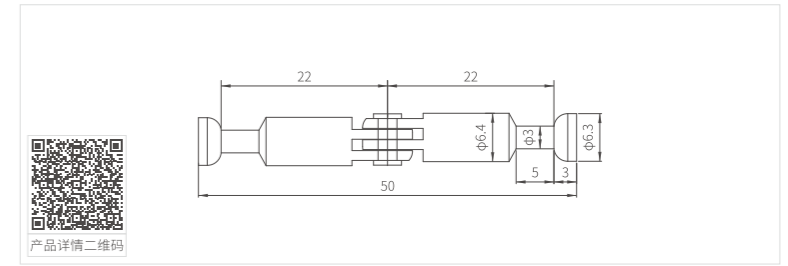

产品详情二维码

MK-KNT-DSZDC-56 带丝折叠杆 MK-KNT-DSZDC-56 Double folded bolt



订货号 Item number	MK-KNT-DSZDC-56
产品材质 Material	碳钢 Carbon steel
表面处理 Finish	蓝白锌 Blue zinc、镍 Nickel

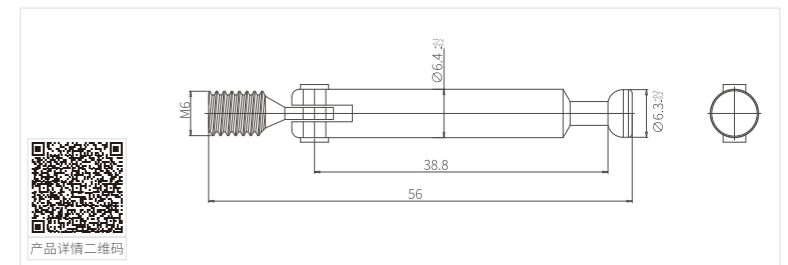

产品详情二维码

MK-ST-3-10-1 金属双头折叠杆 MK-ST-3-10-1 Double folded bolt



订货号 Item number	MK-ST-3-10-1
安装尺寸 Installation size	84mm
产品材质 Material	碳钢 Carbon steel
表面处理 Finish	蓝白锌 Blue zinc

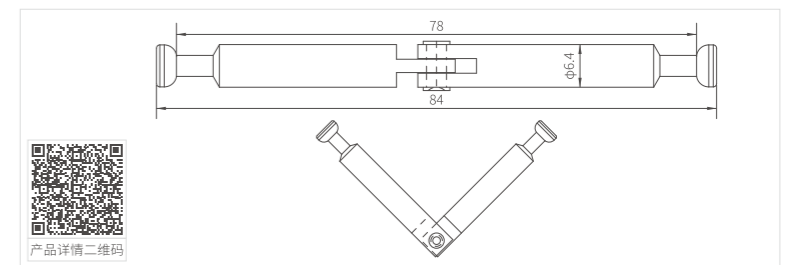

产品详情二维码

MK-DTG-3-8 单头杆 MK-DTG-3-8 Single-ended bolt



订货号 Item number	MK-DTG-3-8
安装尺寸 Installation size	50.8mm
产品材质 Material	碳钢 Carbon steel
表面处理 Finish	镍 Nickel plating

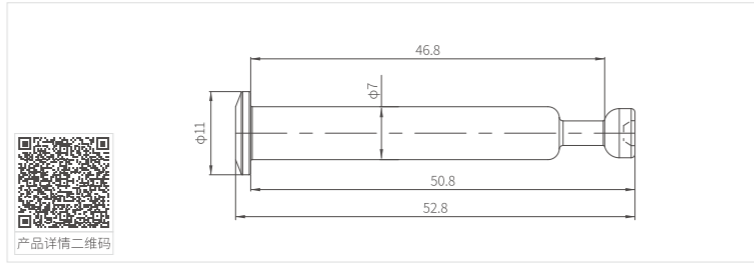

产品详情二维码

MK-64 双头金属杆 MK-64 Double-ended bolt



订货号 Item number	MK-64
产品材质 Material	铁 Iron
表面处理 Finish	蓝白锌 Blue zinc

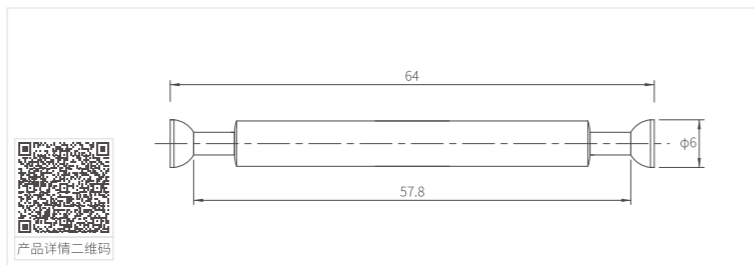

产品详情二维码

MK-ST-3-10-4 包塑双头杆 MK-ST-3-10-4 Plastic double-ended bolt



订货号 Item number	MK-ST-3-10-4
安装尺寸 Installation size	66.2mm
产品材质 Material	碳钢+塑料 Carbon steel+plastic
表面处理 Finish	蓝白锌+黑色 Blue zinc+black

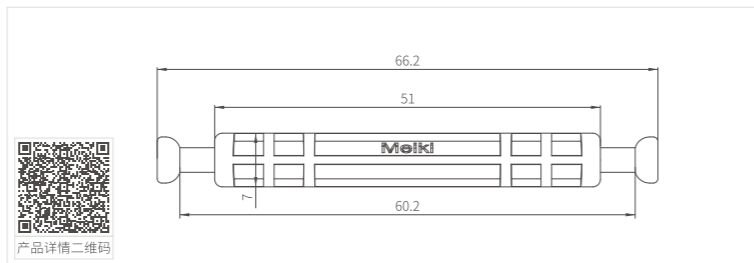

产品详情二维码

MK-MY-10-1-1 米字沉孔木牙 MK-MY-10-1-1 POZI countersunk confirmat screw



订货号 Item number	MK-MY-10-1-1
产品材质 Material	碳钢+塑料 Carbon steel+plastic
表面处理 Finish	蓝白锌 Blue zinc

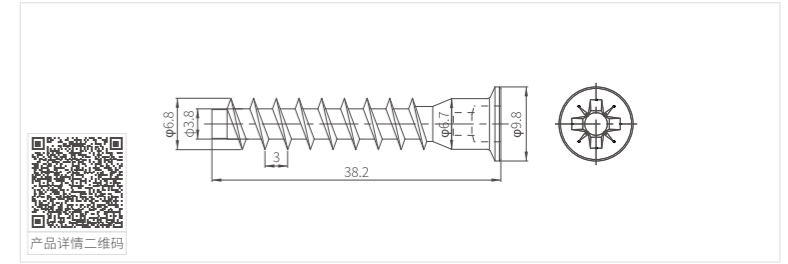

产品详情二维码

MK-MY-10-8-1 内六角木牙 MK-MY-10-8-1 Internal hexagon confirmat screw



订货号 Item number	MK-MY-10-8-1
产品材质 Material	碳钢 Carbon steel
表面处理 Finish	蓝白锌 Blue zinc

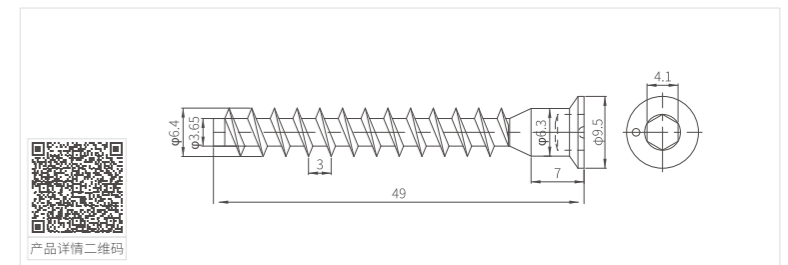

产品详情二维码

MK-MY-10-8-3 内六角木牙 MK-MY-10-8-3 Internal hexagon confirmat screw



订货号 Item number	MK-MY-10-8-3
产品材质 Material	碳钢 Carbon steel
表面处理 Finish	蓝白锌 Blue zinc

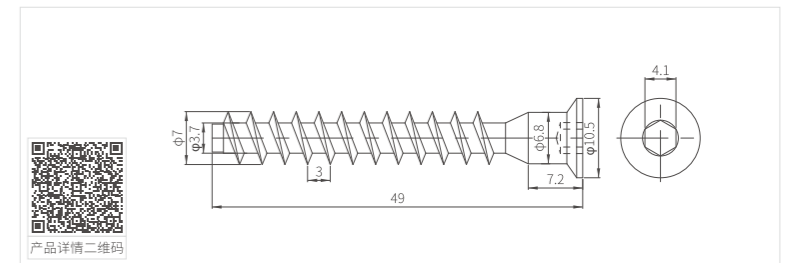

产品详情二维码

MK-KZG-3-11 快装一体杆 (φ10) MK-KZG-3-11 Spreading bolt



订货号 Item number	MK-KZG-3-11 (φ10)
产品材质 Material	碳钢+塑料 Carbon steel+plastic
表面处理 Finish	蓝白锌+黑色 Blue zinc+Black

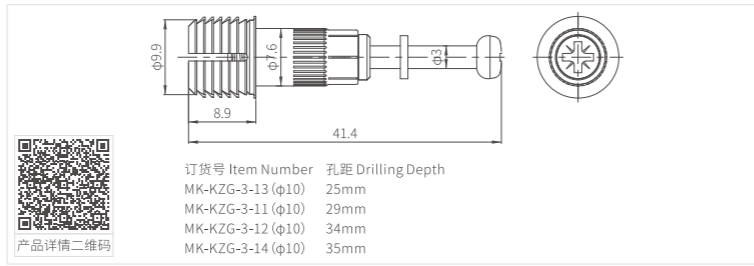

MK-KZG-3-11 快装一体杆 (φ8) MK-KZG-3-11 Spreading bolt



订货号 Item number	MK-KZG-3-11 (φ8)
产品材质 Material	碳钢+塑料 Carbon steel+plastic
表面处理 Finish	蓝白锌+黑色 Blue zinc+Black

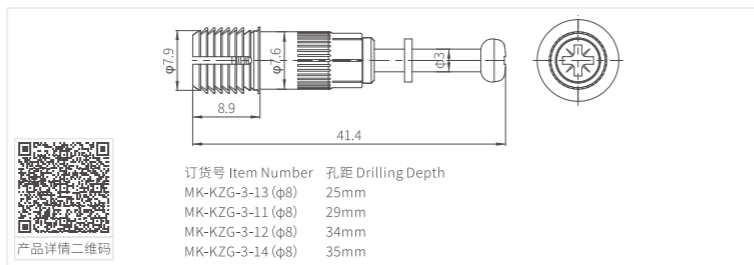

MK-LB-3-3-2 二合一拉爆杆 (φ8) MK-LB-3-3-2 Spreading bolt



订货号 Item number	MK-LB-3-3-2 (φ8)
产品材质 Material	碳钢+尼龙 Carbon steel+nylon
表面处理 Finish	蓝白锌+绿色 Blue zinc+Green

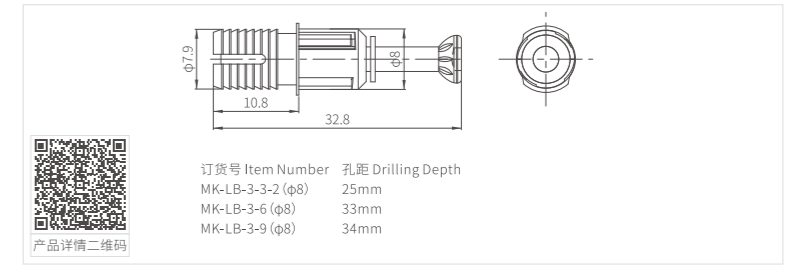

MK-LB-3-9 二合一拉爆杆 (φ10) MK-LB-3-9 Spreading bolt



订货号 Item number	MK-LB-3-9 (φ10)
产品材质 Material	碳钢+尼龙 Carbon steel+nylon
表面处理 Finish	蓝白锌+绿色 Blue zinc+Green

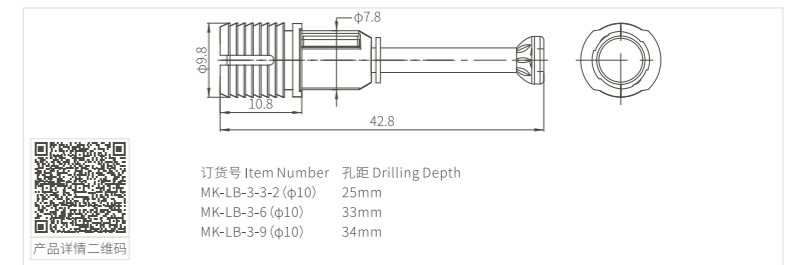

MK-LB-3-3-4 上拉式二合一拉爆杆 (φ8) MK-LB-3-3-4 Pull-up spreading bolt



订货号 Item number	MK-LB-3-3-4 (φ8)
产品材质 Material	碳钢+塑料 Carbon steel+plastic
表面处理 Finish	蓝白锌+黑色 Blue zinc+Black

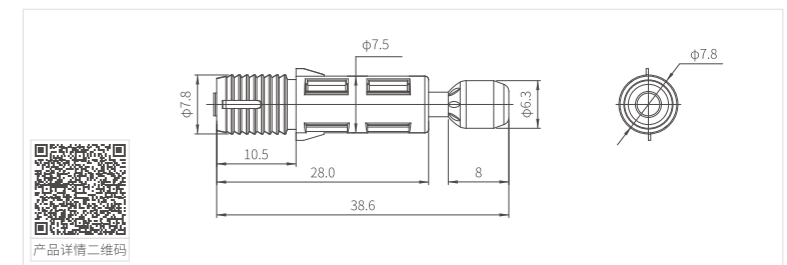

MKBS-LXG-1-2-1 螺旋形隐形连接件 MKBS-LXG-1-2-1 Spiral Invisible connecting bolt



订货号 Item number	MKBS-LXG-1-2-1
产品材质 Material	碳钢+塑料 Carbon steel+plastic
表面处理 Finish	蓝白锌+灰色 Blue zinc+gray

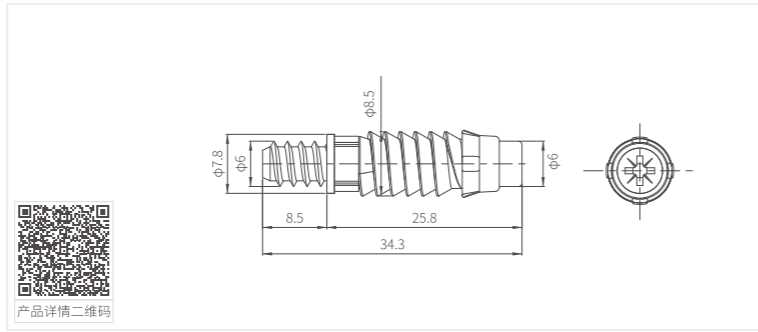

MKBS-LXG-1-2-2 螺旋形隐形连接件 MKBS-LXG-1-2-2 Spiral Invisible connecting bolt



订货号 Item number	MKBS-LXG-1-2-2
产品材质 Material	碳钢+塑料 Carbon steel+plastic
表面处理 Finish	蓝白锌+灰色 Blue zinc+gray

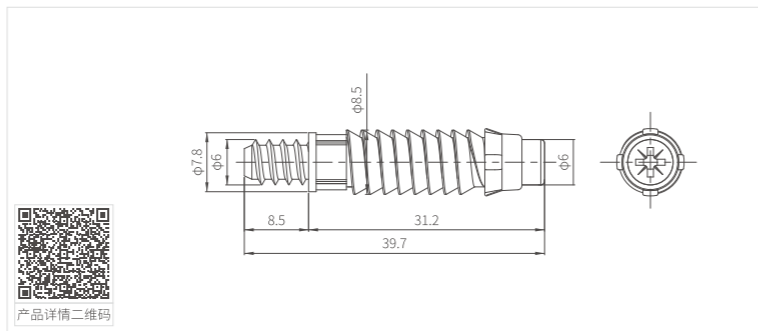

MKBS-LYG-1-2-3 狼牙隐形连接件 MKBS-LYG-1-2-3 Invisible connecting bolt

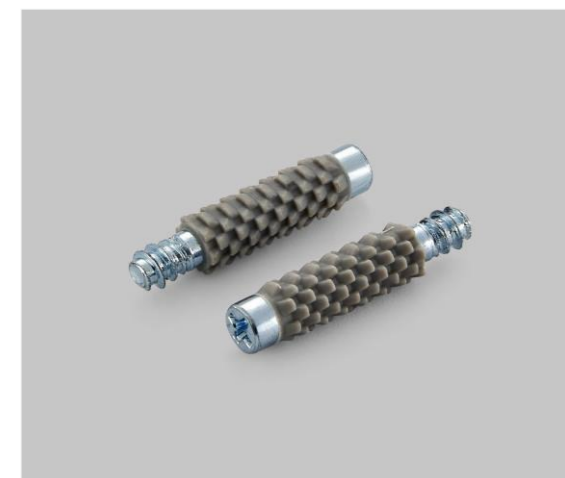

订货号 Item number	MKBS-LYG-1-2-3
产品材质 Material	碳钢+塑料 Carbon steel+plastic
表面处理 Finish	蓝白锌+灰色 Blue zinc+gray

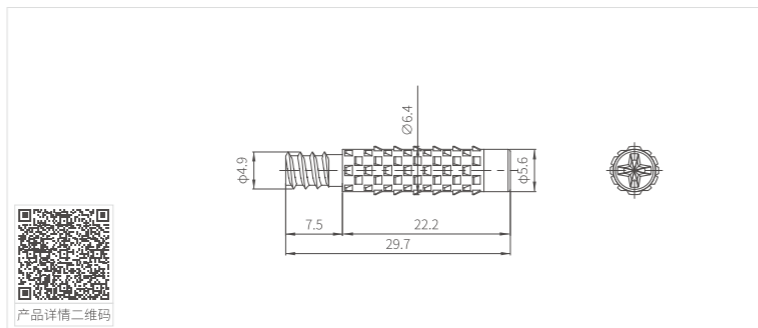

MKBS-YXG-1-9-5 隐形连接件 MKBS-YXG-1-9-5 Invisible connectors



订货号 Item number	MKBS-YXG-1-9-5
产品材质 Material	碳钢+塑料 Carbon steel+plastic
表面处理 Finish	蓝白锌+橙色 Blue zinc+orange

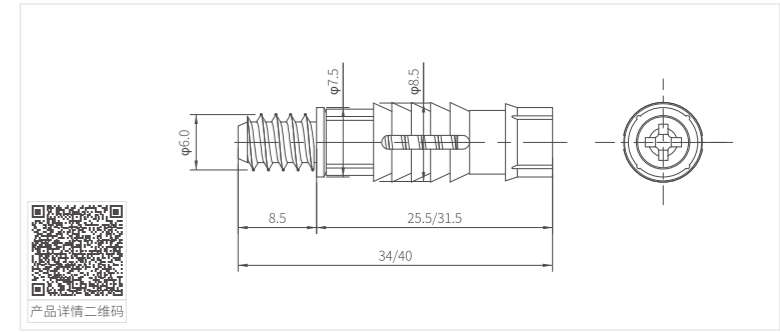

MeiKi明希®
定制家具五金

为全屋定制家具企业提供完整专业的解决方案
Provide complete and professional solutions for whole-house customized furniture enterprises

MK-IF-1# IF隐形连接件 MK-IF-1# IF Invisible Parts



订货号 Item number	MK-IF-1#
产品材质 Material	塑料 Plastic
表面处理 Finish	黑色 Black

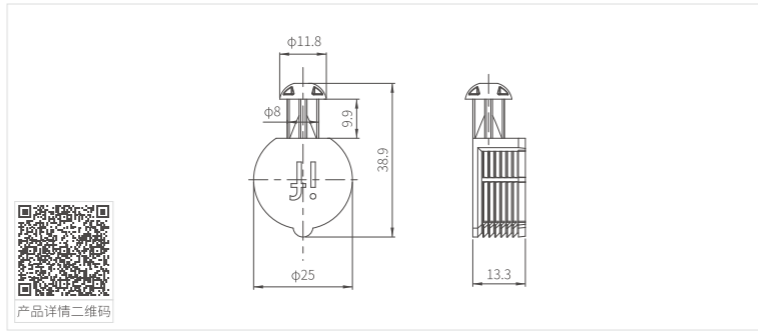

MK-IF-2# IF隐形连接件 MK-IF-2# IF Invisible Parts



订货号 Item number	MK-IF-2#
产品材质 Material	塑料 Plastic
表面处理 Finish	黑色 Black

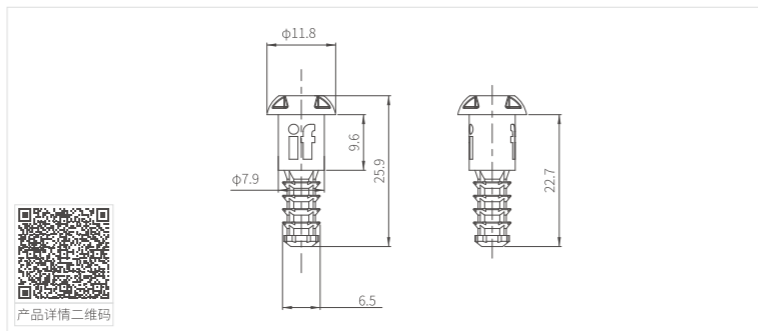

MK-IF-3# IF隐形连接件 MK-IF-3# IF Invisible Parts



订货号 Item number	MK-IF-3#
产品材质 Material	塑料 Plastic
表面处理 Finish	黑色 Black

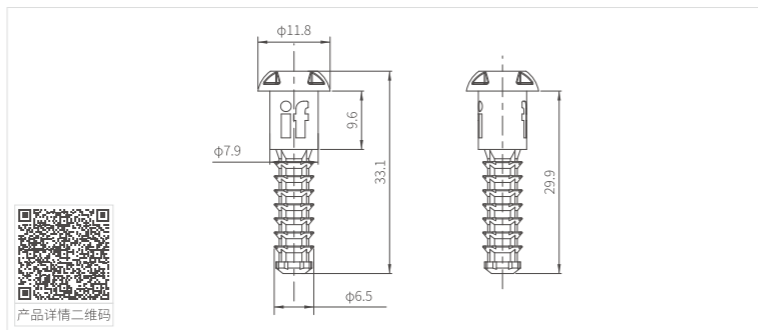

MKBS-2-1 包塑杆 MKBS-2-1 Connecting bolt



订货号 Item number	MKBS-2-1-S9
安装尺寸 Installation size	33.5mm
产品材质 Material	碳钢+塑料 Carbon steel + plastic
包塑可选形状 Optional shape of plastic sleeve	S9环形扣 Ring buckle
连接杆可选颜色 Finish of connecting bolt	蓝白锌 Blue zinc、彩锌 colored zinc
塑料件可选颜色 Finish of plastic sleeve	黑色 Black、蓝色 Blue

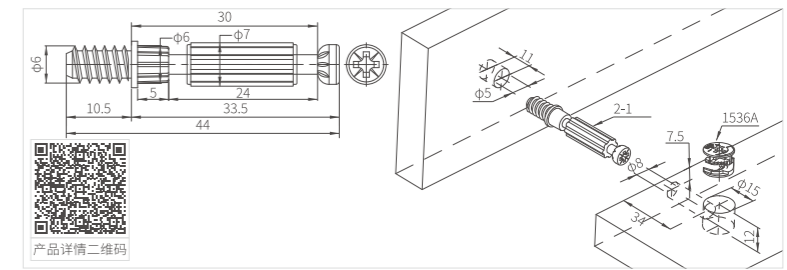

MKBS-2-2 包塑杆 MKBS-2-2 Connecting bolt



订货号 Item number	MKBS-2-2-S9
安装尺寸 Installation size	33.5mm
产品材质 Material	碳钢+塑料 Carbon steel + plastic
包塑可选形状 Optional shape of plastic sleeve	S9环形扣 Ring buckle
连接杆可选颜色 Finish of connecting bolt	蓝白锌 Blue zinc、彩锌 colored zinc
塑料件可选颜色 Finish of plastic sleeve	黑色 Black、蓝色 Blue

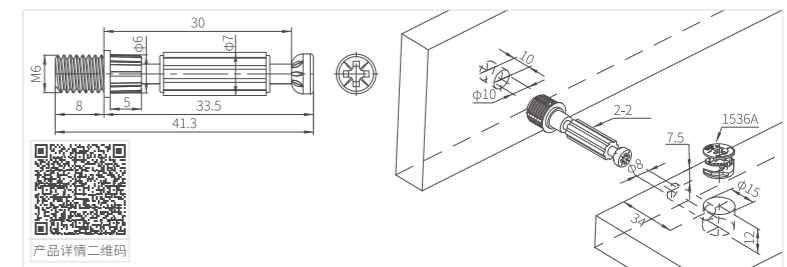

MKBS-1-9-13 包塑杆 MKBS-1-9-13 Connecting bolt



订货号 Item number	MKBS-1-9-13-S6
安装尺寸 Installation size	33.5mm
产品材质 Material	碳钢+塑料 Carbon steel + plastic
包塑可选形状 Optional shape of plastic sleeve	S6
连接杆可选颜色 Finish of connecting bolt	蓝白锌 Blue zinc、彩锌 colored zinc
塑料件可选颜色 Finish of plastic sleeve	黑色 Black、蓝色 Blue

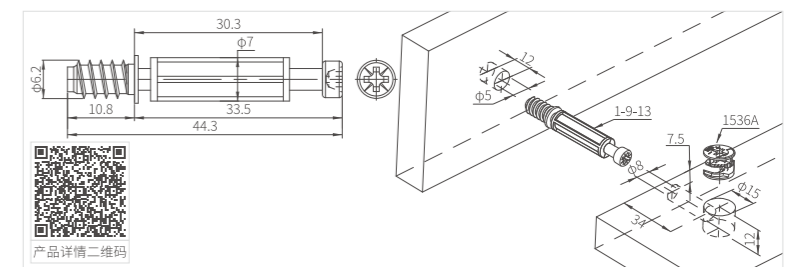

MKBS-1-3-1 包塑杆 MKBS-1-3-1 Connecting bolt



订货号 Item number	MKBS-1-3-1-S5
安装尺寸 Installation size	33.5mm
产品材质 Material	碳钢+塑料 Carbon steel + plastic
包塑可选形状 Optional shape of plastic sleeve	S3/S4/S5
连接杆可选颜色 Finish of connecting bolt	蓝白锌 Blue zinc、彩锌 colored zinc
塑料件可选颜色 Finish of plastic sleeve	黑色 Black、蓝色 Blue

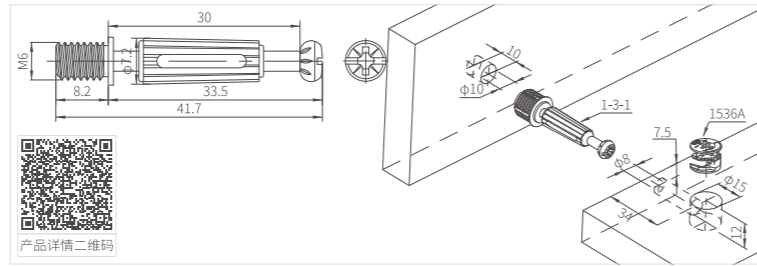

产品详情二维码

MKBS-1-5-1 包塑杆 MKBS-1-5-1 Connecting bolt



订货号 Item number	MKBS-1-5-1-S5
安装尺寸 Installation size	32.5mm
产品材质 Material	碳钢+塑料 Carbon steel + plastic
包塑可选形状 Optional shape of plastic sleeve	S3/S4/S5/S7/S8
连接杆可选颜色 Finish of connecting bolt	蓝白锌 Blue zinc、彩锌 colored zinc
塑料件可选颜色 Finish of plastic sleeve	黑色 Black、蓝色 Blue

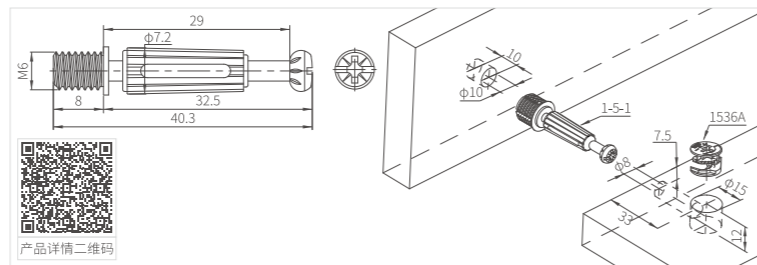

产品详情二维码

MKBS-1-3-3 包塑杆 MKBS-1-3-3 Connecting bolt



订货号 Item number	MKBS-1-3-3-S4
安装尺寸 Installation size	33.5mm
产品材质 Material	碳钢+塑料 Carbon steel + plastic
包塑可选形状 Optional shape of plastic sleeve	S4
连接杆可选颜色 Finish of connecting bolt	蓝白锌 Blue zinc、彩锌 colored zinc
塑料件可选颜色 Finish of plastic sleeve	黑色 Black、蓝色 Blue

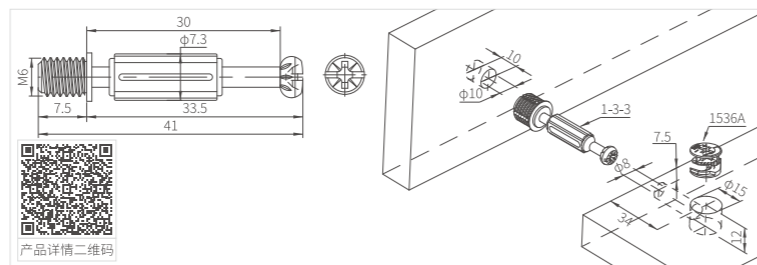

产品详情二维码

MKBS-1-9-2 包塑杆 MKBS-1-9-2 Connecting bolt

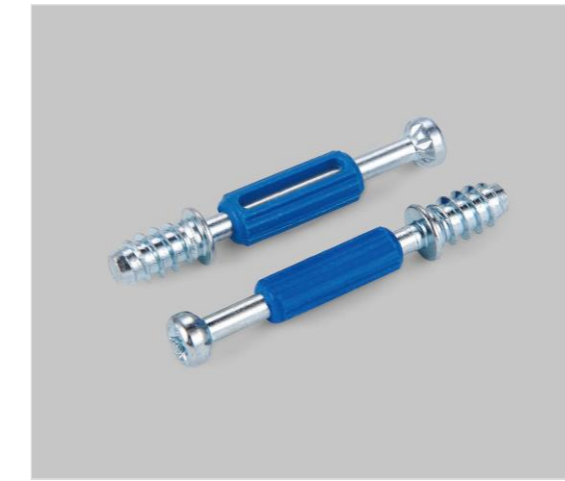

订货号 Item number	MKBS-1-9-2-S4
安装尺寸 Installation size	33.5mm
产品材质 Material	碳钢+塑料 Carbon steel + plastic
包塑可选形状 Optional shape of plastic sleeve	S1/S4
连接杆可选颜色 Finish of connecting bolt	蓝白锌 Blue zinc、彩锌 colored zinc
塑料件可选颜色 Finish of plastic sleeve	黑色 Black、蓝色 Blue

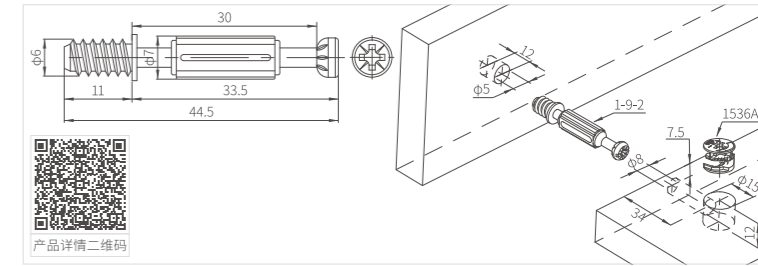

产品详情二维码

MKBS-1-9-18 包塑杆 MKBS-1-9-18 Connecting bolt



订货号 Item number	MKBS-1-9-18-S4
安装尺寸 Installation size	33.5mm
产品材质 Material	碳钢+塑料 Carbon steel + plastic
包塑可选形状 Optional shape of plastic sleeve	S4
连接杆可选颜色 Finish of connecting bolt	蓝白锌 Blue zinc、彩锌 colored zinc
塑料件可选颜色 Finish of plastic sleeve	黑色 Black、蓝色 Blue

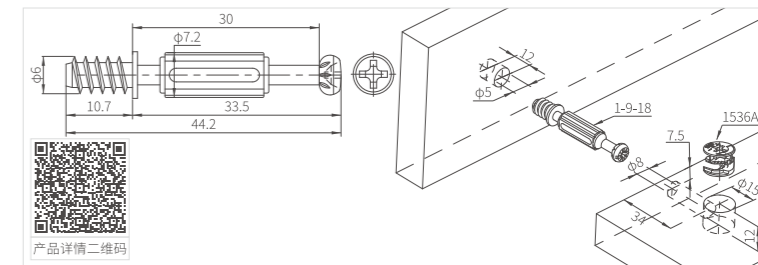

产品详情二维码

MKBS-1-9-24 包塑杆 MKBS-1-9-24 Connecting bolt



订货号 Item number	MKBS-1-9-24-S5
安装尺寸 Installation size	28.5mm
产品材质 Material	碳钢+塑料 Carbon steel + plastic
包塑可选形状 Optional shape of plastic sleeve	S5
连接杆可选颜色 Finish of connecting bolt	蓝白锌 Blue zinc、彩锌 colored zinc
塑料件可选颜色 Finish of plastic sleeve	黑色 Black、蓝色 Blue

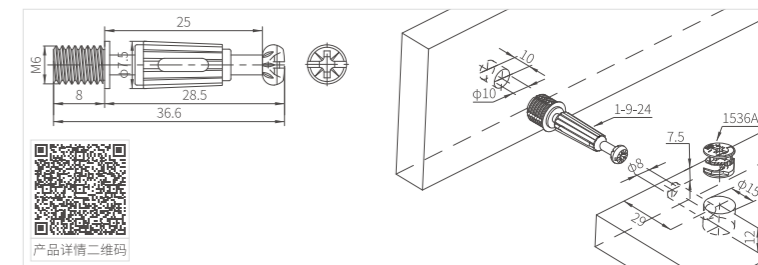

产品详情二维码

MKBS-1-9-42 包塑杆 MKBS-1-9-42 Connecting bolt



订货号 Item number	MKBS-1-9-42-S5
安装尺寸 Installation size	33.5mm
产品材质 Material	碳钢+塑料 Carbon steel + plastic
包塑可选形状 Optional shape of plastic sleeve	S5
连接杆可选颜色 Finish of connecting bolt	蓝白锌 Blue zinc、彩锌 colored zinc
塑料件可选颜色 Finish of plastic sleeve	黑色 Black、蓝色 Blue

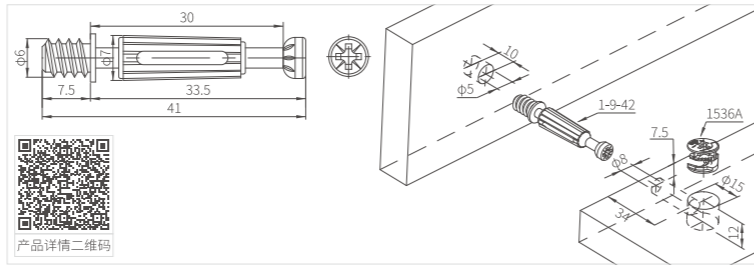

产品详情二维码

MKBS-1-9-22 包塑杆 MKBS-1-9-22 Connecting bolt



订货号 Item number	MKBS-1-9-22-S7
安装尺寸 Installation size	33.5mm
产品材质 Material	碳钢+塑料 Carbon steel + plastic
包塑可选形状 Optional shape of plastic sleeve	S4/S7
连接杆可选颜色 Finish of connecting bolt	蓝白锌 Blue zinc、彩锌 colored zinc
塑料件可选颜色 Finish of plastic sleeve	黑色 Black、蓝色 Blue

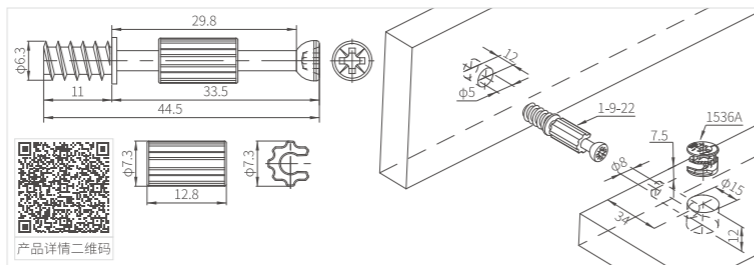

产品详情二维码

MKBS-1-9-26 包塑杆 MKBS-1-9-26 Connecting bolt



订货号 Item number	MKBS-1-9-26-S2
安装尺寸 Installation size	24mm
产品材质 Material	碳钢+塑料 Carbon steel + plastic
包塑可选形状 Optional shape of plastic sleeve	S2
连接杆可选颜色 Finish of connecting bolt	蓝白锌 Blue zinc、彩锌 colored zinc
塑料件可选颜色 Finish of plastic sleeve	黑色 Black、蓝色 Blue

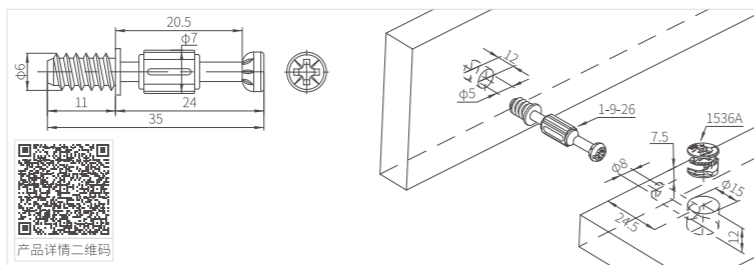

产品详情二维码

MKBS-1-9-30 包塑杆 MKBS-1-9-30 Connecting bolt



订货号 Item number	MKBS-1-9-30-S2
安装尺寸 Installation size	28mm
产品材质 Material	碳钢+塑料 Carbon steel + plastic
包塑可选形状 Optional shape of plastic sleeve	S2
连接杆可选颜色 Finish of connecting bolt	蓝白锌 Blue zinc、彩锌 colored zinc
塑料件可选颜色 Finish of plastic sleeve	黑色 Black、蓝色 Blue

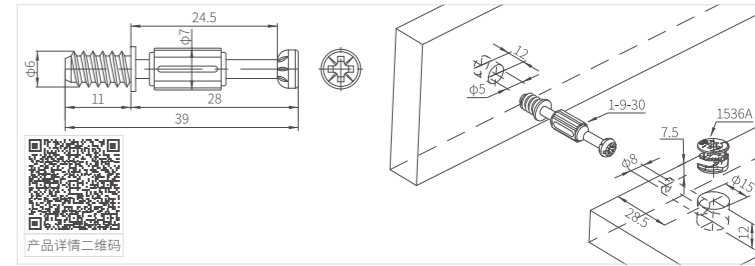

产品详情二维码

MKBS-1-1-1 包塑杆 MKBS-1-1-1 Connecting bolt

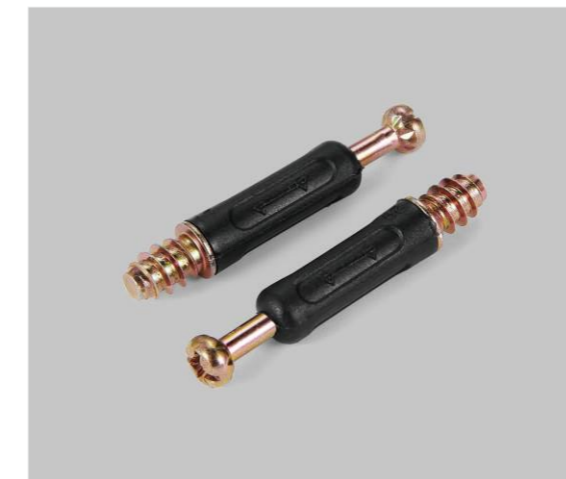

订货号 Item number	MKBS-1-1-1-S3
安装尺寸 Installation size	33.5mm
产品材质 Material	碳钢+塑料 Carbon steel + plastic
包塑可选形状 Optional shape of plastic sleeve	S1/S3/S4/S5
连接杆可选颜色 Finish of connecting bolt	蓝白锌 Blue zinc、彩锌 colored zinc
塑料件可选颜色 Finish of plastic sleeve	黑色 Black、蓝色 Blue

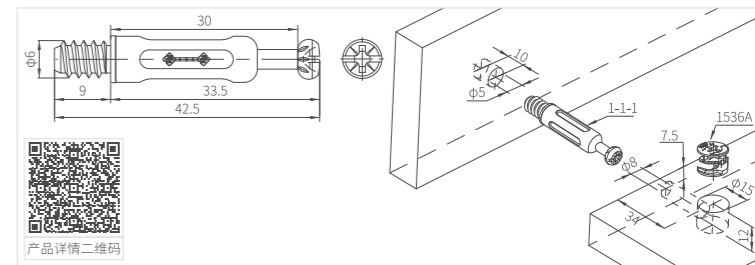

产品详情二维码

MKBS-1-3-1 包塑杆 MKBS-1-3-1 Connecting bolt



订货号 Item number	MKBS-1-3-1-S3
安装尺寸 Installation size	33.5mm
产品材质 Material	碳钢+塑料 Carbon steel + plastic
包塑可选形状 Optional shape of plastic sleeve	S3/S4/S5
连接杆可选颜色 Finish of connecting bolt	蓝白锌 Blue zinc、彩锌 colored zinc
塑料件可选颜色 Finish of plastic sleeve	黑色 Black、蓝色 Blue

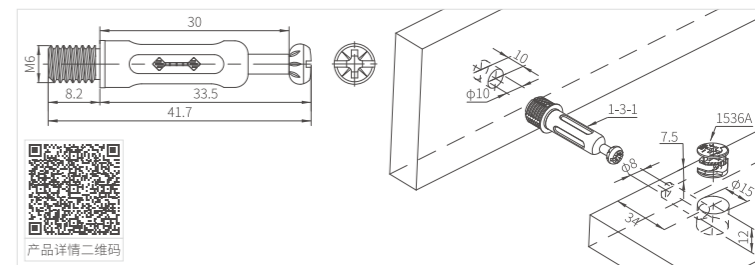

产品详情二维码

MKBS-1-5-1 包塑杆 MKBS-1-5-1 Connecting bolt



订货号 Item number	MKBS-1-5-1-S3
安装尺寸 Installation size	32.5mm
产品材质 Material	碳钢+塑料 Carbon steel + plastic
包塑可选形状 Optional shape of plastic sleeve	S3/S4/S5/S7/S8
连接杆可选颜色 Finish of connecting bolt	蓝白锌 Blue zinc、彩锌 colored zinc
塑料件可选颜色 Finish of plastic sleeve	黑色 Black、蓝色 Blue

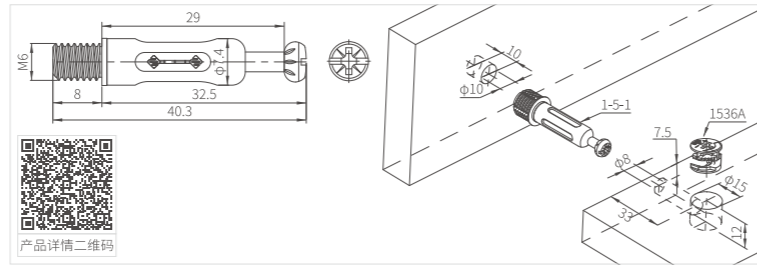

产品详情二维码

MKBS-1-8-2 包塑杆 MKBS-1-8-2 Connecting bolt



订货号 Item number	MKBS-1-8-2-S3
安装尺寸 Installation size	24.5mm
产品材质 Material	碳钢+塑料 Carbon steel + plastic
包塑可选形状 Optional shape of plastic sleeve	S2/S3
连接杆可选颜色 Finish of connecting bolt	蓝白锌 Blue zinc、彩锌 colored zinc
塑料件可选颜色 Finish of plastic sleeve	黑色 Black、蓝色 Blue

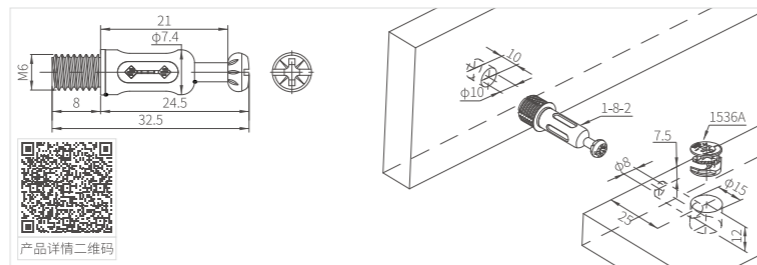

产品详情二维码

MKBS-1-5-6 包塑杆 MKBS-1-5-6 Connecting bolt



订货号 Item number	MKBS-1-5-6-S8
安装尺寸 Installation size	32.5mm
产品材质 Material	碳钢+塑料 Carbon steel + plastic
包塑可选形状 Optional shape of plastic sleeve	S3/S5/S8
连接杆可选颜色 Finish of connecting bolt	蓝白锌 Blue zinc、彩锌 colored zinc
塑料件可选颜色 Finish of plastic sleeve	黑色 Black、蓝色 Blue

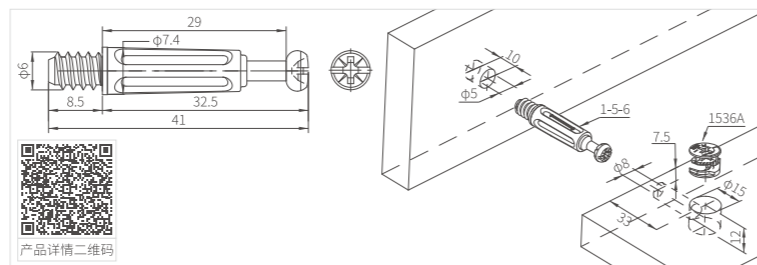

产品详情二维码

MKBS-1-9-28 包塑杆 MKBS-1-9-28 Connecting bolt



订货号 Item number	MKBS-1-9-28
安装尺寸 Installation size	33mm
产品材质 Material	碳钢+塑料 Carbon steel + plastic
包塑可选形状 Optional shape of plastic sleeve	/
连接杆可选颜色 Finish of connecting bolt	蓝白锌 Blue zinc、彩锌 colored zinc
塑料件可选颜色 Finish of plastic sleeve	黑色 Black、蓝色 Blue

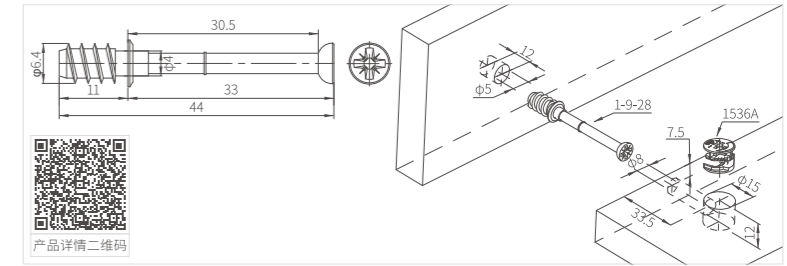

产品详情二维码

MKBS-1-9-35 包塑杆 MKBS-1-9-35 Connecting bolt



订货号 Item number	MKBS-1-9-35
安装尺寸 Installation size	33mm
产品材质 Material	碳钢+塑料 Carbon steel + plastic
包塑可选形状 Optional shape of plastic sleeve	/
连接杆可选颜色 Finish of connecting bolt	蓝白锌 Blue zinc、彩锌 colored zinc
塑料件可选颜色 Finish of plastic sleeve	黑色 Black、蓝色 Blue

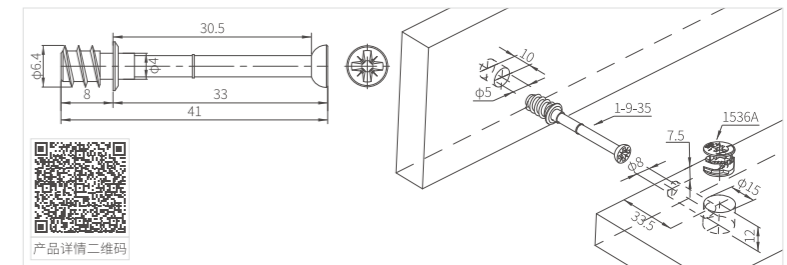

产品详情二维码

MKBS-1-9-36 包塑杆 MKBS-1-9-36 Connecting bolt

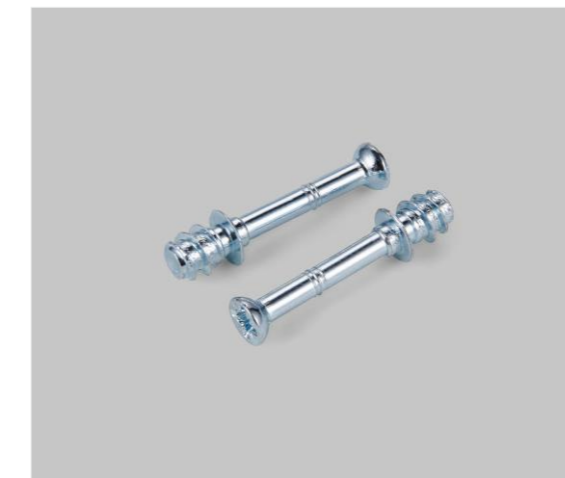

订货号 Item number	MKBS-1-9-36
安装尺寸 Installation size	23mm
产品材质 Material	碳钢+塑料 Carbon steel + plastic
包塑可选形状 Optional shape of plastic sleeve	/
连接杆可选颜色 Finish of connecting bolt	蓝白锌 Blue zinc、彩锌 colored zinc
塑料件可选颜色 Finish of plastic sleeve	黑色 Black、蓝色 Blue

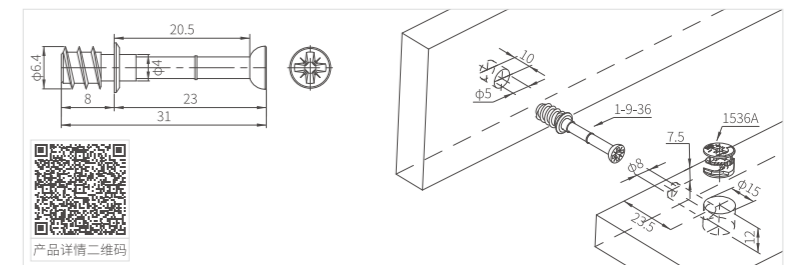

产品详情二维码



MeiKi明希®

STRONG CONNECTOR SERIES
强力连接件系列

STRONG CONNECTION UNBREAKABLE
强力连接 固若金汤

加深加密螺纹, 加倍稳固
厚重板材也能轻松连接

Encrypted tightening threads for extra stability
Easy connection even with heavy plates

MK-QLJ-5-15-1 强力连接件 MK-QLJ-5-15-1 Strong connector



订货号 Item number	MK-QLJ-5-15-1
产品材质 Material	碳钢 Carbon steel
表面处理 Finish	蓝白锌 Blue zinc, 枪色 Gun-black
适配榔头 Applicable nut	MK-QLJ-24-01-01

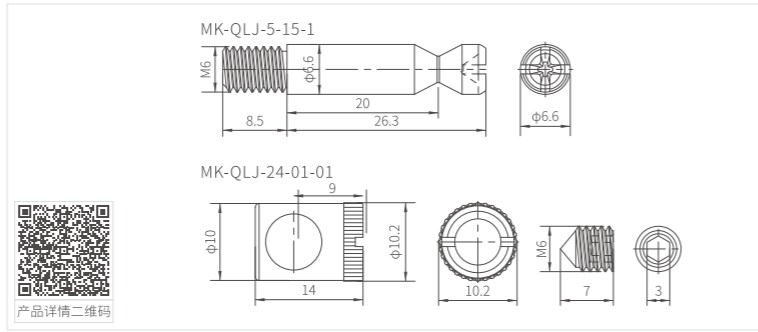

产品详情二维码

MK-QLJ-5-15-12 强力连接件 MK-QLJ-5-15-12 Strong connector



订货号 Item number	MK-QLJ-5-15-12
产品材质 Material	碳钢 Carbon steel
表面处理 Finish	蓝白锌 Blue zinc, 枪色 Gun-black
适配榔头 Applicable nut	MK-QLJ-24-01-01

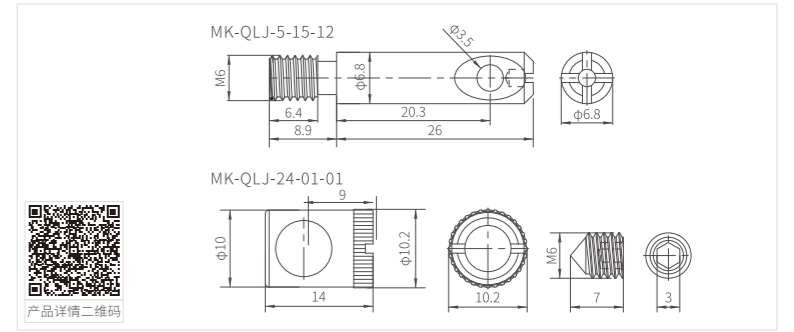

产品详情二维码

MK-QLJ-5-15-2 强力连接件 MK-QLJ-5-15-2 Strong connector



订货号 Item number	MK-QLJ-5-15-2
产品材质 Material	碳钢 Carbon steel
表面处理 Finish	蓝白锌 Blue zinc, 枪色 Gun-black, 彩锌 Colored zinc
适配榔头 Applicable nut	MK-QLJ-24-01-02

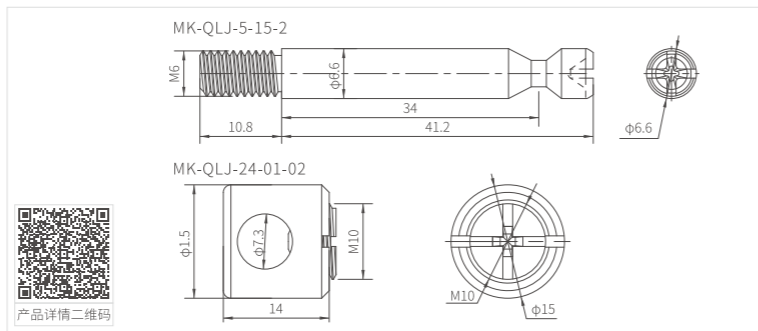

产品详情二维码

MK-QLJ-5-15-13 强力连接件 MK-QLJ-5-15-13 Strong connector



订货号 Item number	MK-QLJ-5-15-13
产品材质 Material	碳钢 Carbon steel
表面处理 Finish	蓝白锌 Blue zinc, 枪色 Gun-black
适配榔头 Applicable nut	MK-QLJ-24-01-07

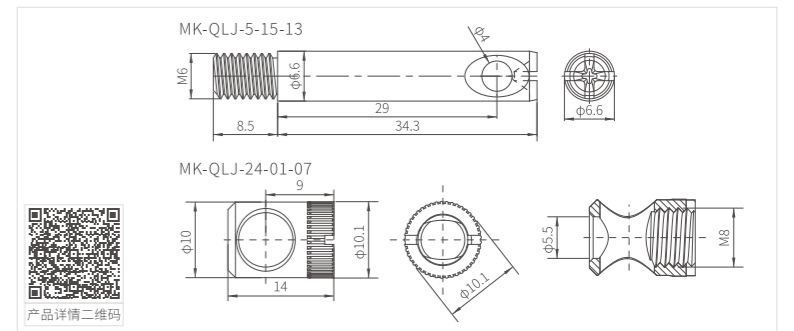

产品详情二维码

MK-QLJ-5-17 强力连接件 MK-QLJ-5-17 Strong connector



订货号 Item number	MK-QLJ-5-17
产品材质 Material	碳钢 Carbon steel
表面处理 Finish	蓝白锌 Blue zinc, 枪色 Gun-black
适配榔头 Applicable nut	MK-QLJ-24-01-06

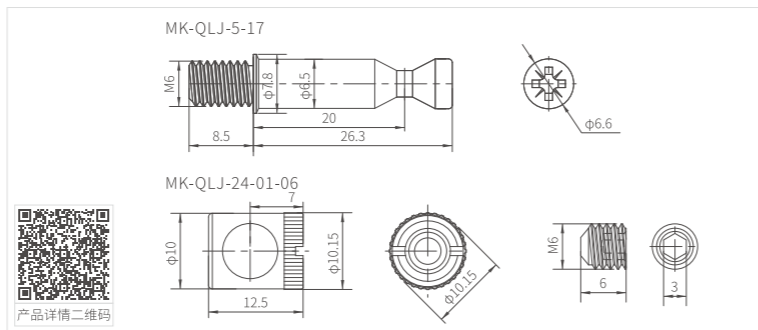

产品详情二维码

MK-KNT-NXQLJ-35MM 内旋强力连接件 MK-KNT-NXQLJ-35MM Internal Rotation Strong Connector



订货号 Item number	MK-KNT-NXQLJ-35MM
产品材质 Material	锌合金+碳钢 Zinc alloy+Carbon steel
表面处理 Finish	蓝白锌 Blue zinc, 镍 Nickel
适配连接杆 Application Connector	68mm、88mm

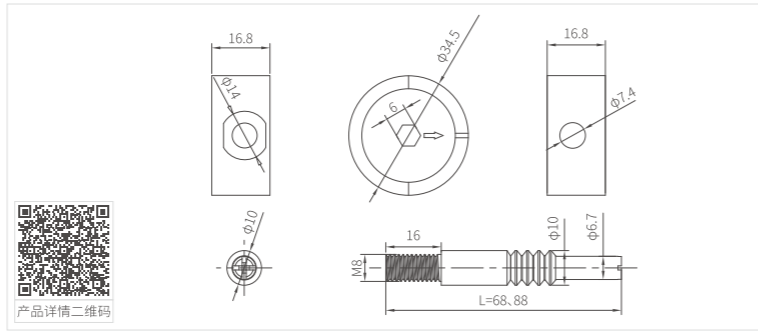

MK-QLJ-54-00-44 内旋强力连接件 MK-QLJ-54-00-44 Internal Rotation Strong Connector



订货号 Item number	MK-QLJ-54-00-44
产品材质 Material	锌合金 Zinc alloy
表面处理 Finish	蓝白锌 Blue zinc
适配连接杆 Application Connector	5-15-3

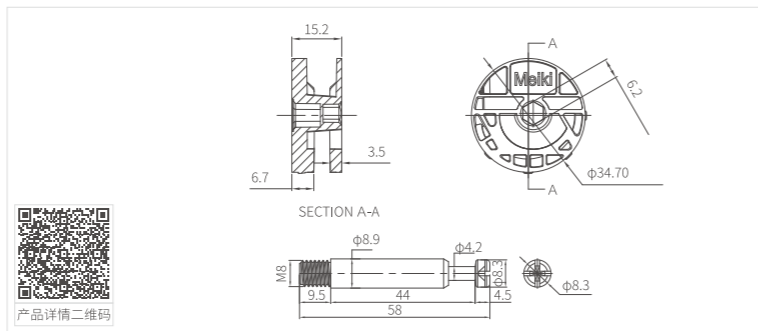

MK-LFBLJ-34-01-01 16板铝蜂板连接件 MK-LFBLJ-34-01-01 P16-Panel Aluminum honeycomb panel connector



订货号 Item number	MK-LFBLJ-34-01-01
产品材质 Material	碳钢+塑料 Carbon steel+plastic
表面处理 Finish	按样品 By sample

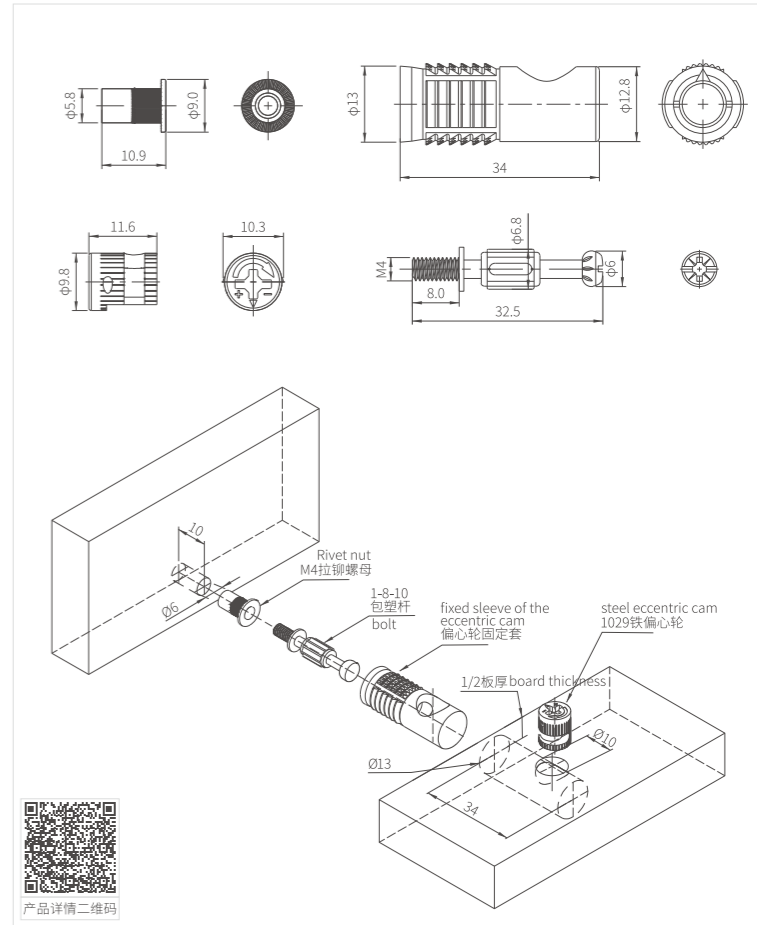



MeiKi明希®

BOLT AND DECORATIVE SCREW SERIES
螺杆装饰螺丝系列

CRAFTED WITH EXQUISITE DETAIL
精雕细琢 细节考究

螺纹深邃, 不易滑牙, 不晃动
防锈能力更强, 时光见证品质
Deep thread, not easy to slip teeth, no shaking
Stronger rust resistance, time witness quality

MK-ZSLS-12-7-9 十字机丝牙装饰螺丝 MK-ZSLS-12-7-9 Phillips thread decorative screw



订货号 Item number	MK-ZSLS-12-7-9
产品材质 Material	碳钢 Carbon steel
表面处理 Finish	蓝白锌 Blue zinc、镍 Nickel
装饰盖配 Decorative cap	9#32-01-11
装饰盖材质 Decorative cap material	塑料 Plastic
装饰盖可选颜色 Decorative cap finish	枪色 Gun-black、哑光银 Matte silver

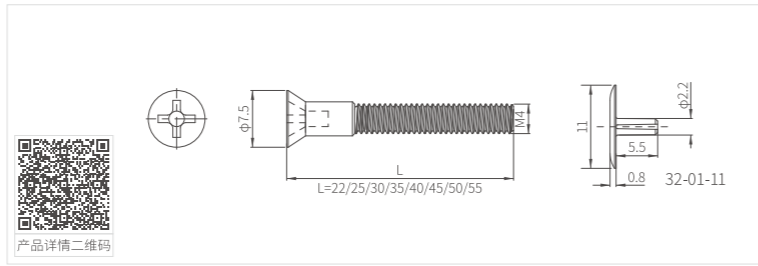

产品详情二维码

MK-ZSLS-12-7-5 十字自攻装饰螺丝 MK-ZSLS-12-7-5 Phillips self-driven decorative screw



订货号 Item number	MK-ZSLS-12-7-5
产品材质 Material	碳钢 Carbon steel
表面处理 Finish	蓝白锌 Blue zinc、镍 Nickel
装饰盖配 Decorative cap	9#32-01-11
装饰盖材质 Decorative cap material	塑料 Plastic
装饰盖可选颜色 Decorative cap finish	枪色 Gun-black、哑光银 Matte silver

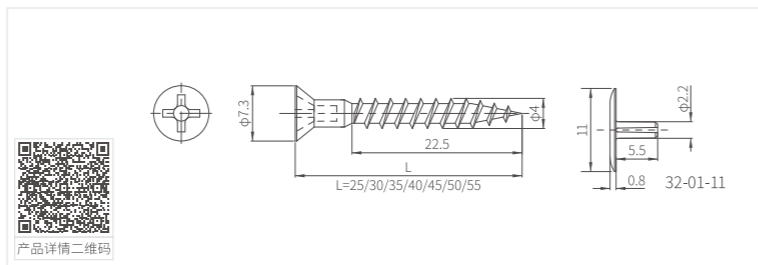

产品详情二维码

MKLG-12-9-3 大扁头内六角螺栓 MKLG-12-9-3 Round head hexagon bolt



订货号 Item number	MKLG-12-9-3
产品材质 Material	铁 Iron
表面处理 Finish	彩锌 Colored zinc、蓝白锌 Blue zinc 镍 Nickel plating、黑锌 Black zinc

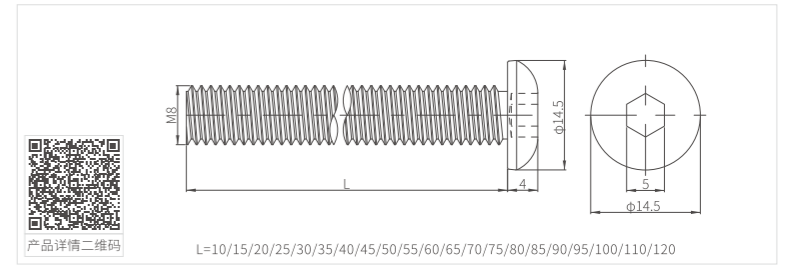

产品详情二维码

MKLG-12-9-13 大扁头内六角螺栓 MKLG-12-9-13 Round head hexagon bolt



订货号 Item number	MKLG-12-9-13
产品材质 Material	铁 Iron
表面处理 Finish	彩锌 Colored zinc、蓝白锌 Blue zinc 镍 Nickel plating、黑锌 Black zinc

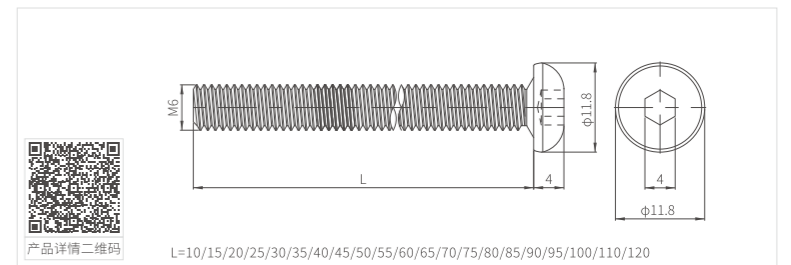

产品详情二维码

MKLG-12-2-1 平元十一字螺杆 MKLG-12-2-1 Pan head phillips slot bolt

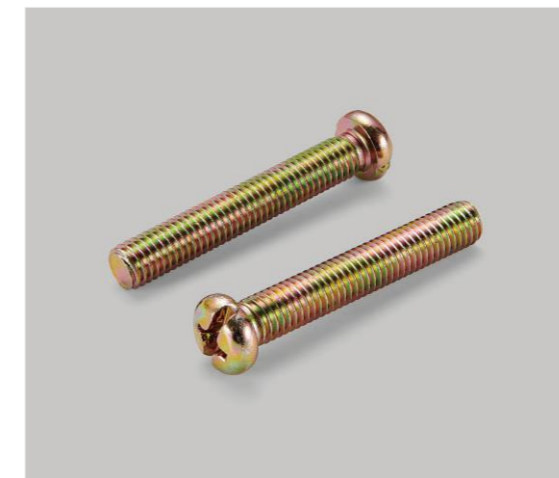

订货号 Item number	MKLG-12-2-1
产品材质 Material	铁 Iron
表面处理 Finish	彩锌 Colored zinc、蓝白锌 Blue zinc 镍 Nickel plating、黑锌 Black zinc

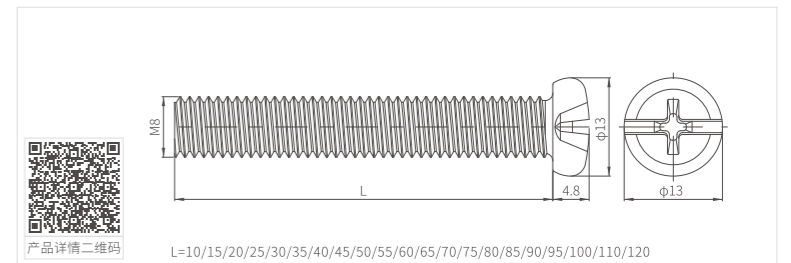

产品详情二维码

MKLG-12-2-7 平元内六角螺栓 MKLG-12-2-7 Pan head hexagon bolt

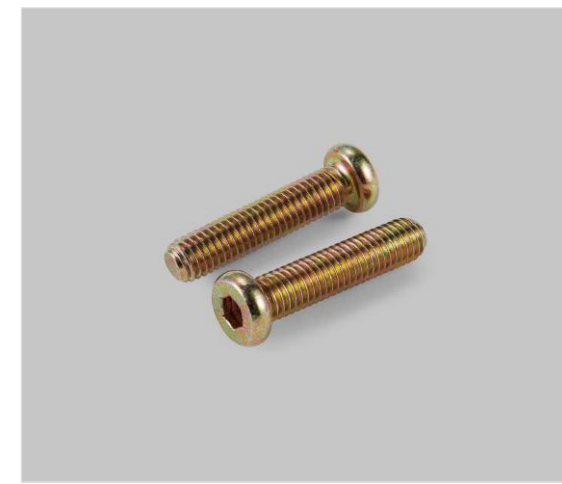

订货号 Item number	MKLG-12-2-7
产品材质 Material	铁 Iron
表面处理 Finish	彩锌 Colored zinc、蓝白锌 Blue zinc 镍 Nickel plating、黑锌 Black zinc

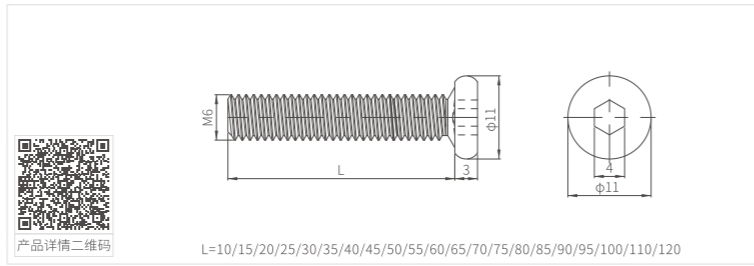

MKLG-12-2-3 平元内六角螺栓 MKLG-12-2-3 Pan head hexagon bolt



订货号 Item number	MKLG-12-2-3
产品材质 Material	铁 Iron
表面处理 Finish	彩锌 Colored zinc、蓝白锌 Blue zinc 镍 Nickel plating、黑锌 Black zinc

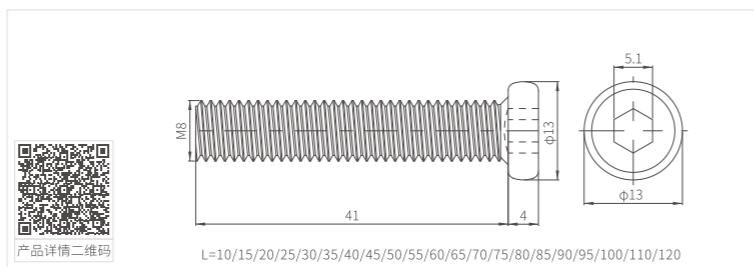

MKLG-12-1-1 倒边十字螺栓 MKLG-12-1-1 Flat chamfered head phillips bolt

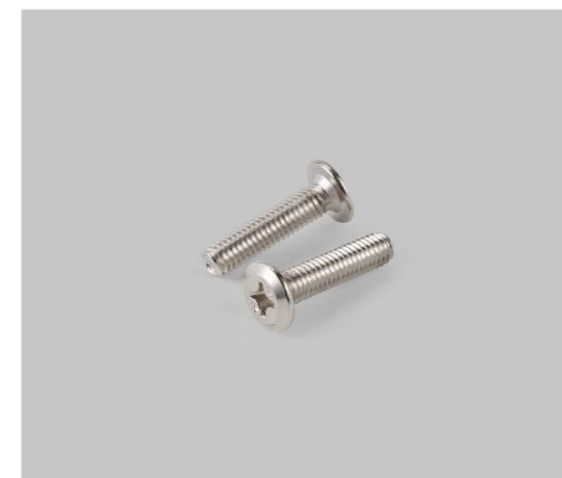

订货号 Item number	MKLG-12-1-1
产品材质 Material	铁 Iron
表面处理 Finish	彩锌 Colored zinc、蓝白锌 Blue zinc 镍 Nickel plating、黑锌 Black zinc

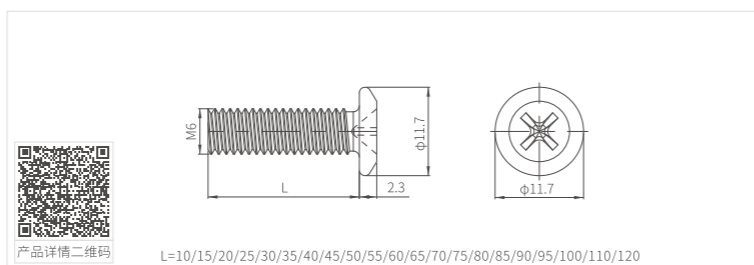

MKLG-M8FY 倒边内六角螺栓 MKLG-M8FY Chamfered hexagon bolt



订货号 Item number	MKLG-M8FY
产品材质 Material	铁 Iron
表面处理 Finish	彩锌 Colored zinc、蓝白锌 Blue zinc 镍 Nickel plating、黑锌 Black zinc

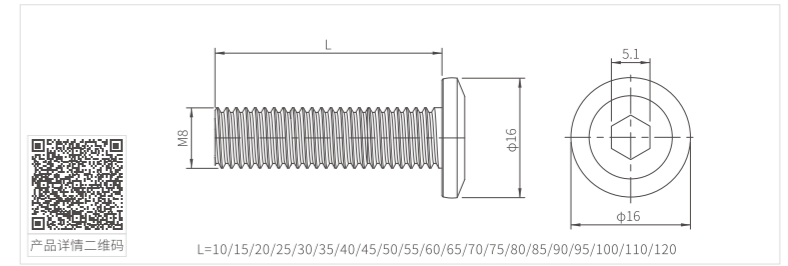

MKLG-M10SJ 双牙单尖拍扁螺栓 MKLG-M10SJ Double-ended thread hanger bolt

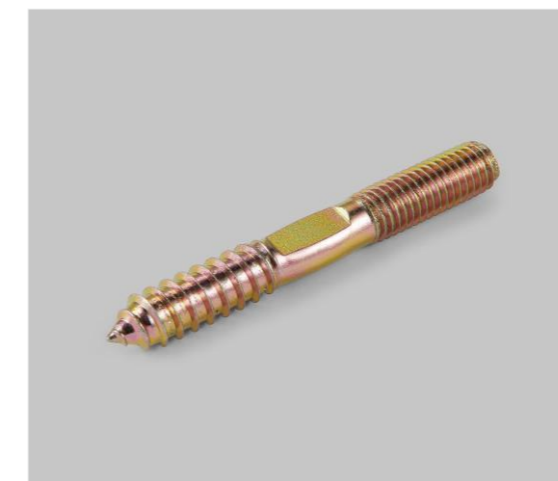

订货号 Item number	MKLG-M10SJ
产品材质 Material	铁 Iron
表面处理 Finish	彩锌 Colored zinc、蓝白锌 Blue zinc 镍 Nickel plating、黑锌 Black zinc

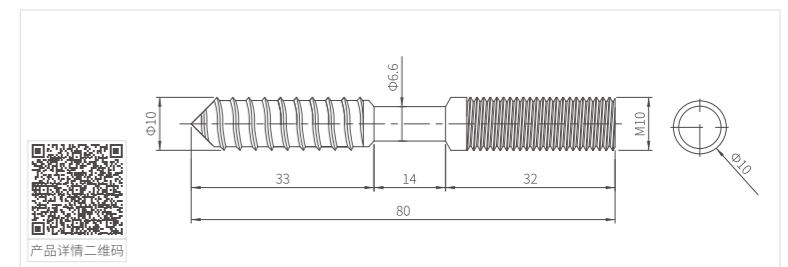

MKLG-M4LH 4厘沉头螺丝 MKLG-M4LH Countersunk head bolt

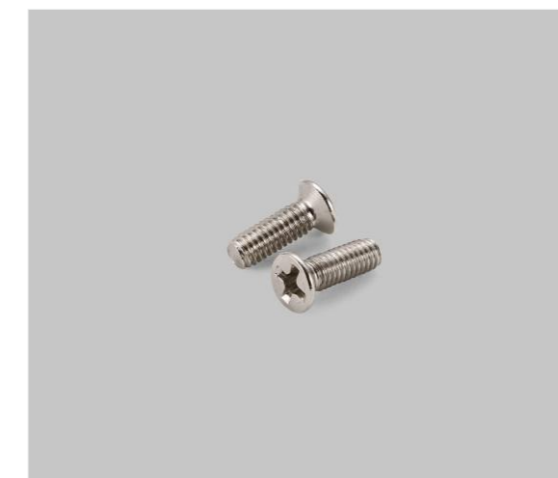

订货号 Item number	MKLG-M4LH
产品材质 Material	铁 Iron
表面处理 Finish	彩锌 Colored zinc、蓝白锌 Blue zinc 镍 Nickel plating、黑锌 Black zinc

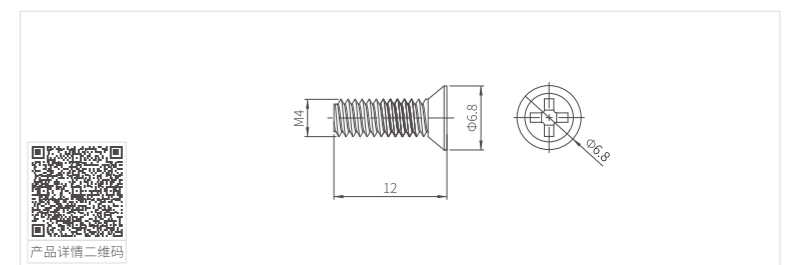

MKLG-M4-30-ZH 组合螺丝 MKLG-M4-30-ZH Furniture combination bolt



订货号 Item number	MKLG-M4-30-ZH
产品材质 Material	铁 Iron
表面处理 Finish	彩锌 Colored zinc、蓝白锌 Blue zinc 镍 Nickel plating、黑锌 Black zinc

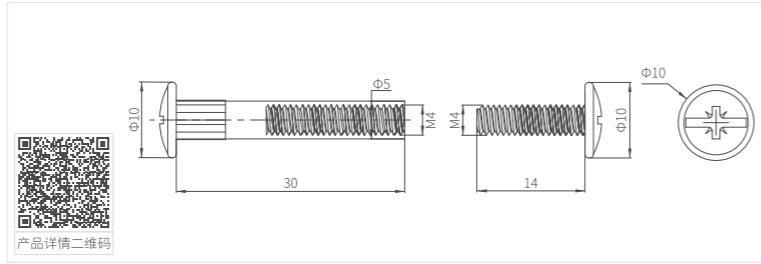

MKLG-13-7-1 内六角螺丝 MKLG-13-7-1 Hexagon screw



订货号 Item number	MKLG-13-7-1
产品材质 Material	碳钢 Carbon steel
表面处理 Finish	彩锌 Colored zinc、蓝白锌 Blue zinc 镍 Nickel plating、黑锌 Black zinc

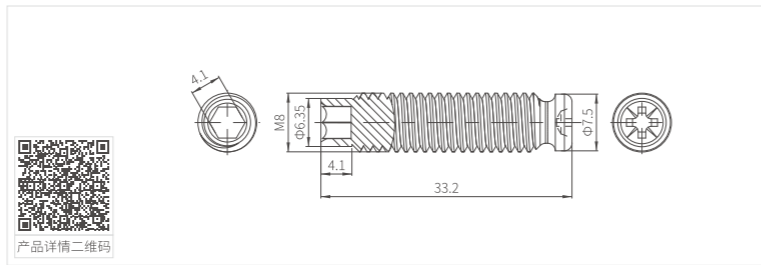

MeiKi明希®

SHELF SUPPORT SCREW SERIES
板托螺丝系列

ONE-PIECE MOLDING IS DURABLE
一体成型 经久耐用

自带螺纹, 安装便捷
紧密衔接, 久用稳固如初
With thread, easy to install
Close connection, long lasting stable as before

MKZZ-13-1 中柱 MKZZ-13-1 Shelf support



订货号 Item number	MKZZ-13-1
产品材质 Material	碳钢 Carbon steel
表面处理 Finish	镍 Nickel plating、蓝白锌 Blue zinc

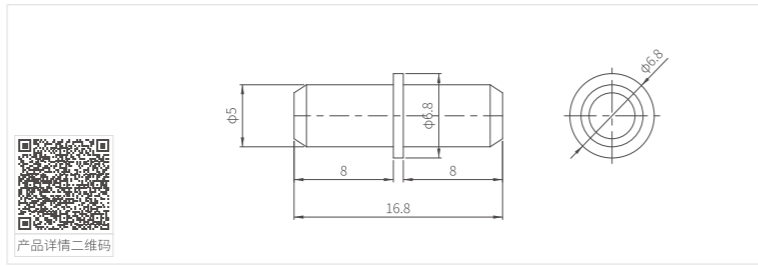

MKZZ-13-1-1 中柱 MKZZ-13-1-1 Shelf support



订货号 Item number	MKZZ-13-1-1
产品材质 Material	碳钢 Carbon steel
表面处理 Finish	镍 Nickel plating、蓝白锌 Blue zinc

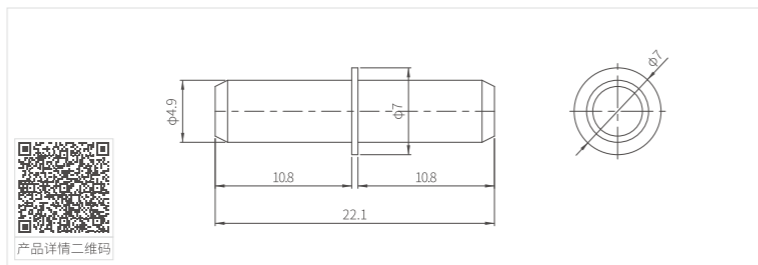

MKGBD-13-2-1 隔板钉 MKGBD-13-2-1 Shelf support screw

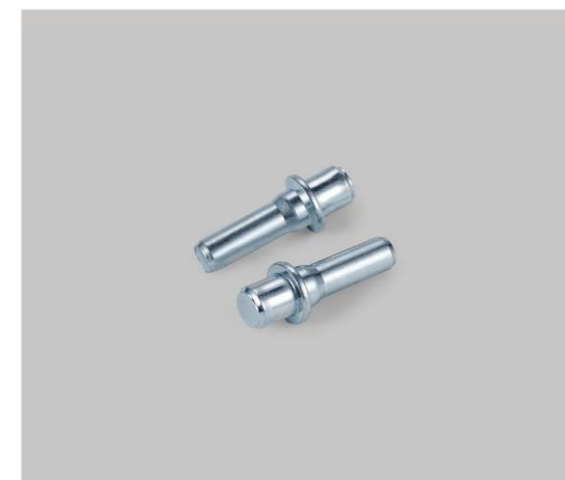

订货号 Item number	MKGBD-13-2-1
产品材质 Material	碳钢 Carbon steel
表面处理 Finish	镍 Nickel plating、蓝白锌 Blue zinc

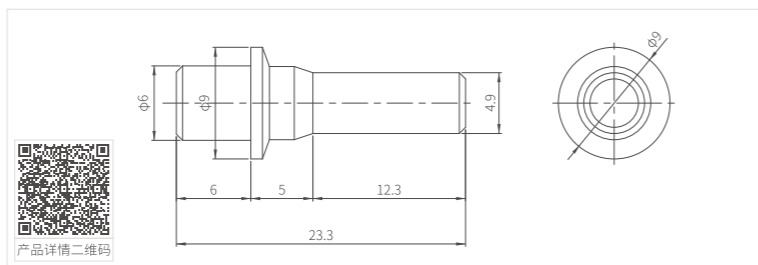

MKGBD-13-2-2 隔板钉 MKGBD-13-2-2 Shelf support screw



订货号 Item number	MKGBD-13-2-2
产品材质 Material	碳钢 Carbon steel
表面处理 Finish	镍 Nickel plating、蓝白锌 Blue zinc

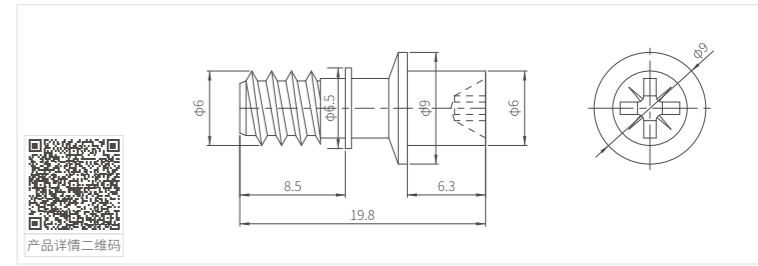

MKGBD-13-2-3 隔板钉 MKGBD-13-2-3 Self-driven screw

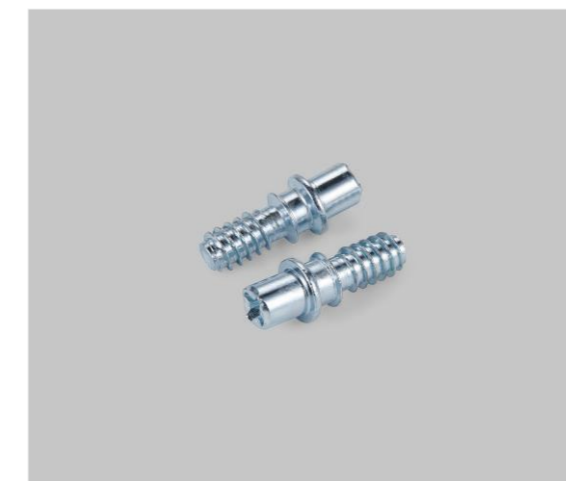

订货号 Item number	MKGBD-13-2-3
产品材质 Material	碳钢 Carbon steel
表面处理 Finish	镍 Nickel plating、蓝白锌 Blue zinc

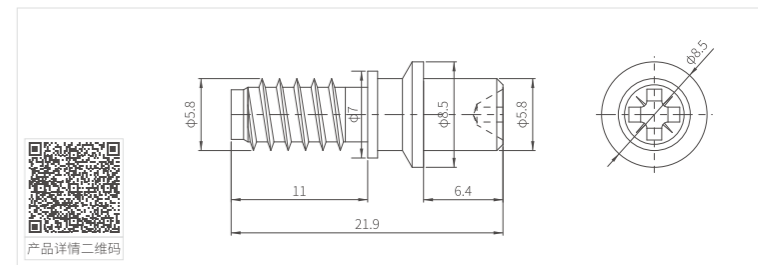

MKGBD-13-2-4 隔板钉 MKGBD-13-2-4 Shelf support screw



订货号 Item number	MKGBD-13-2-4
产品材质 Material	碳钢 Carbon steel
表面处理 Finish	镍 Nickel plating、蓝白锌 Blue zinc

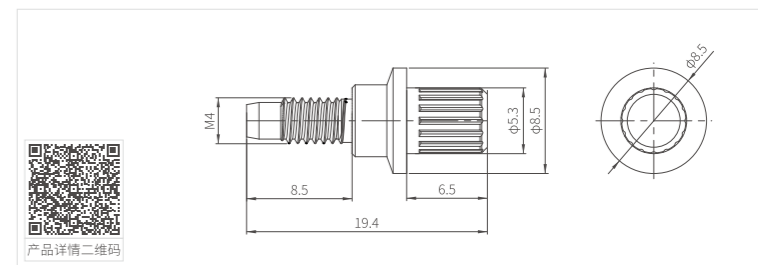

MKBTLS-9-5 T型板托螺丝 MKBTLS-9-5 Shelf support screw

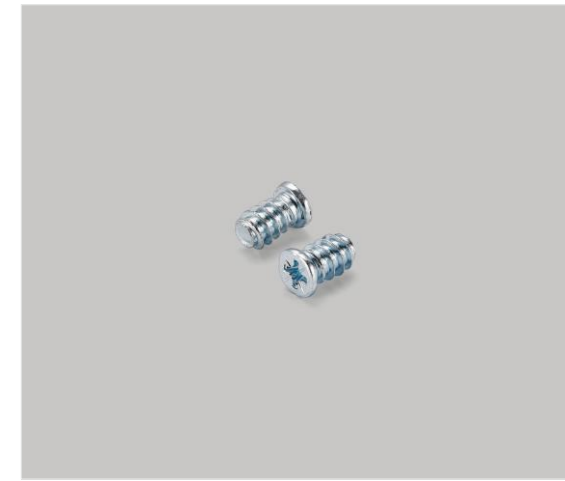

订货号 Item number	MKBTLS-9-5
产品材质 Material	碳钢 Carbon steel
表面处理 Finish	镍 Nickel plating、蓝白锌 Blue zinc

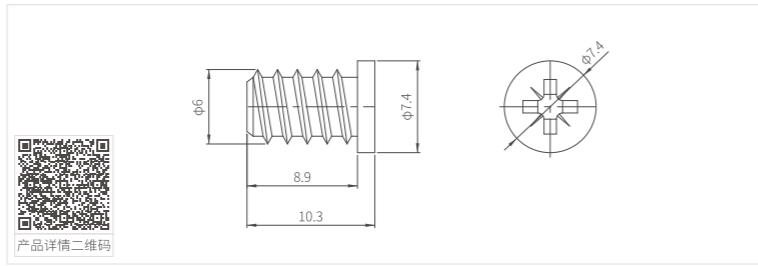

MKCT-9-5-4 沉头螺丝 MKCT-9-5-4 Countersunk screw

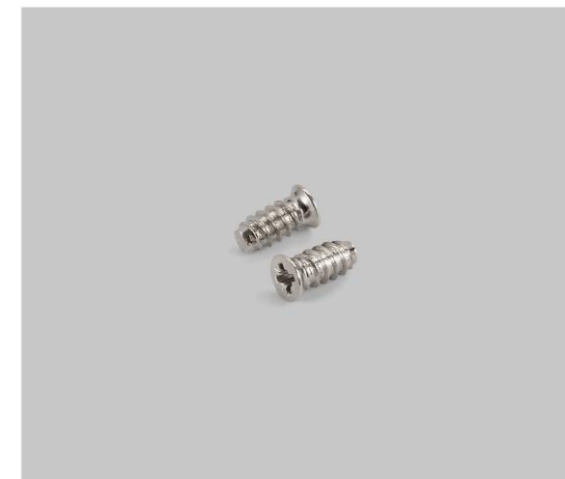

订货号 Item number	MKCT-9-5-4
产品材质 Material	碳钢 Carbon steel
表面处理 Finish	镍 Nickel plating、蓝白锌 Blue zinc

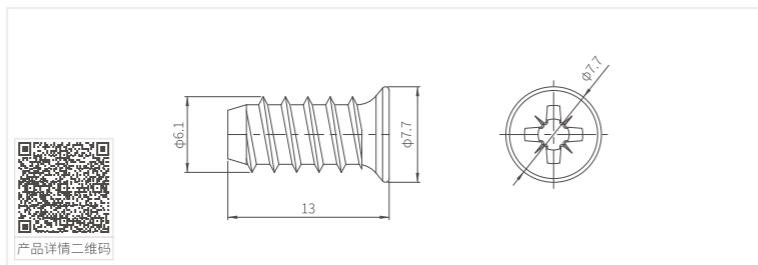

MKBTLS-9-8-11 板托螺丝 MKBTLS-9-8-11 Shelf support screw

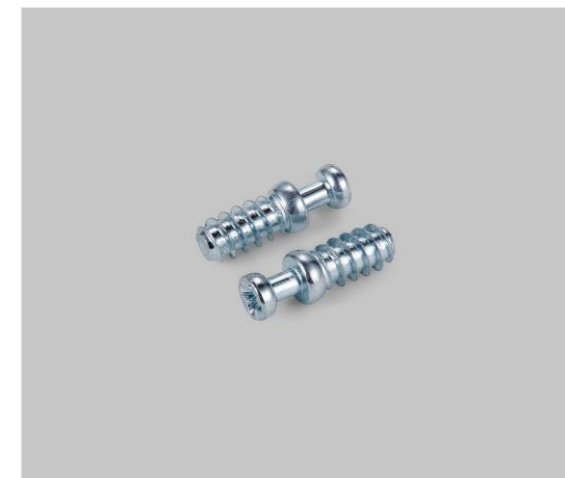

订货号 Item number	MKBTLS-9-8-11
产品材质 Material	碳钢 Carbon steel
表面处理 Finish	蓝白锌 Blue zinc

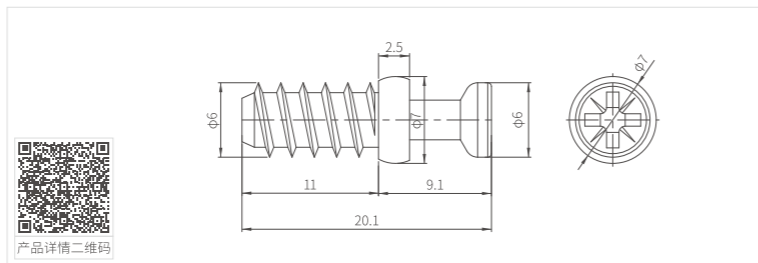

MKBTLS-9-8-12 板托螺丝 MKBTLS-9-8-12 Shelf support screw



订货号 Item number	MKBTLS-9-8-12
产品材质 Material	碳钢 Carbon steel
表面处理 Finish	蓝白锌 Blue zinc

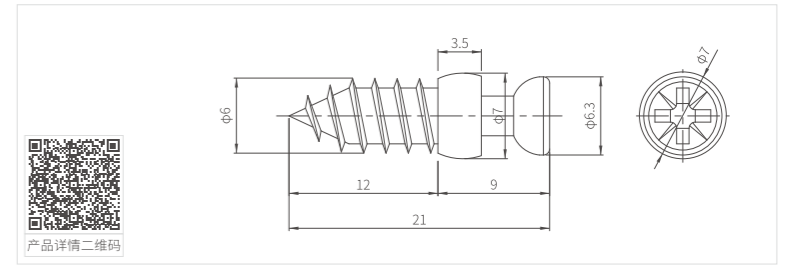

MKBTLS-9-8-5 板托螺丝 MKBTLS-9-8-5 Shelf support screw



订货号 Item number	MKBTLS-9-8-5
产品材质 Material	碳钢 Carbon steel
表面处理 Finish	蓝白锌 Blue zinc

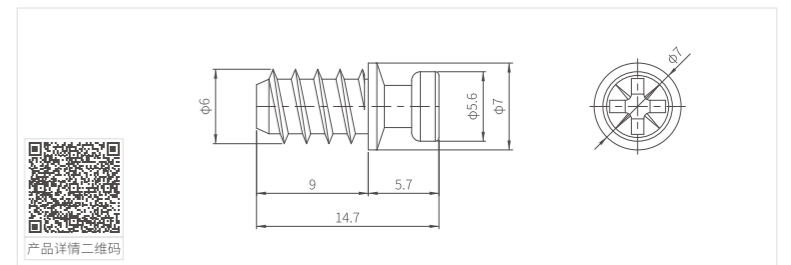

MeiKi明希®

DECORATIVE COVER OF ECCENTRIC CAM SERIES
偏心轮装饰盖系列



PRACTICAL, BEAUTIFUL AND EASY TO INSTALL
实用美观 安装简易

简约时尚, 让家具更美观
轻按即可完成安装, 高效快捷
Simple fashion, make furniture more beautiful
Tap to complete the installation, efficient and fast

MK-KG-53-00-06 1#12锌合金孔盖 MK-KG-53-00-06 1# 12 Zinc alloy cover



订货号 Item number	MK-KG-53-00-06
产品材质 Material	锌合金 Zinc alloy
表面处理 Finish	镍 Nickel plating、枪色 Gun-black

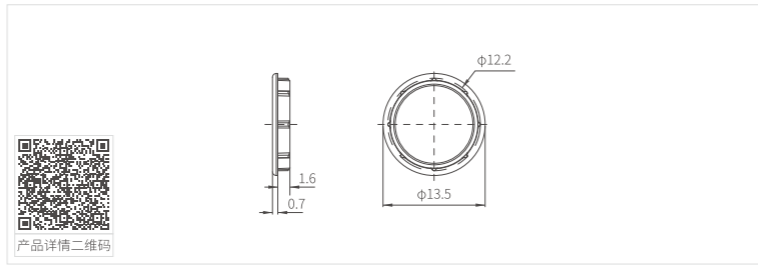

产品详情二维码

MK-KG-53-00-01 2#10锌合金孔盖 MK-KG-53-00-01 2# 10 Zinc alloy cover



订货号 Item number	MK-KG-53-00-01
产品材质 Material	锌合金 Zinc alloy
表面处理 Finish	镍 Nickel plating、枪色 Gun-black

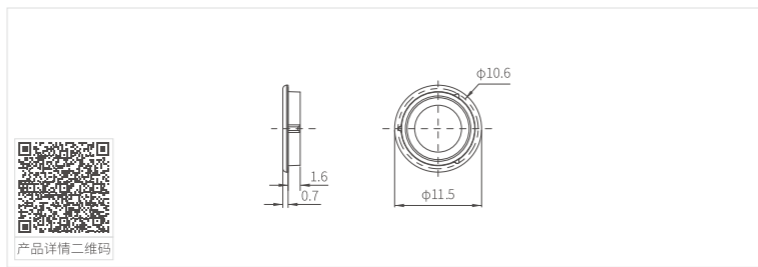

产品详情二维码

MK-KG-32-01-09 3# 12下沉式塑料盖 MK-KG-32-01-09 3# 12 Countersunk plastic cover



订货号 Item number	MK-KG-32-01-09
产品材质 Material	塑料 Plastic
表面处理 Finish	哑光银 Matte silver、枪色 Gun-black

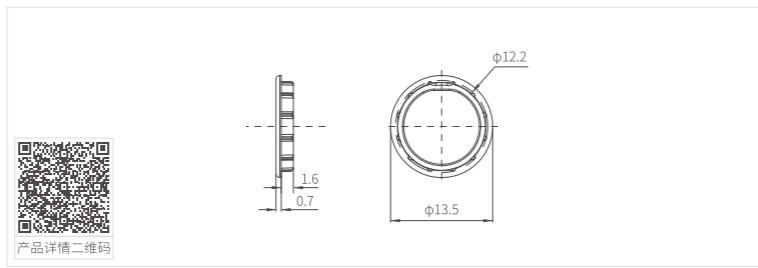

产品详情二维码

MK-KG-32-01-08 4# 10下沉式塑料盖 MK-KG-32-01-08 4# 10 Countersunk plastic cover



订货号 Item number	MK-KG-32-01-08
产品材质 Material	塑料 Plastic
表面处理 Finish	哑光银 Matte silver、枪色 Gun-black

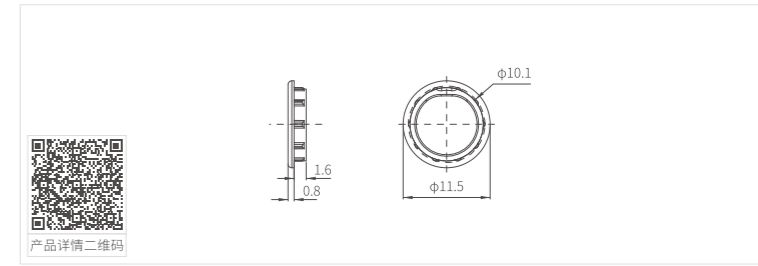

产品详情二维码

MK-KG-32-01-04 5# 15塑料盖 MK-KG-32-01-04 5# 15 Plastic cover



订货号 Item number	MK-KG-32-01-04
产品材质 Material	塑料 Plastic
表面处理 Finish	白色 White、哑光银 Matte silver、枪色 Gun-black

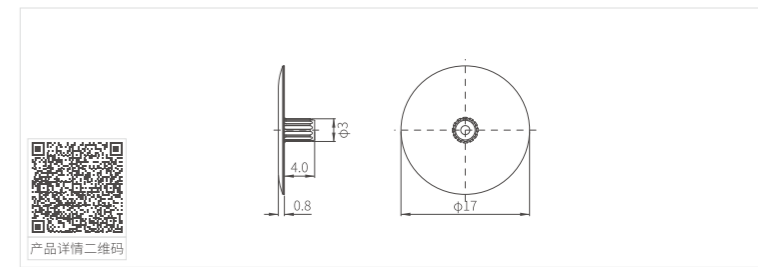

产品详情二维码

MK-KG-32-01-02 6# 12塑料盖 MK-KG-32-01-02 6# 12 Plastic cover

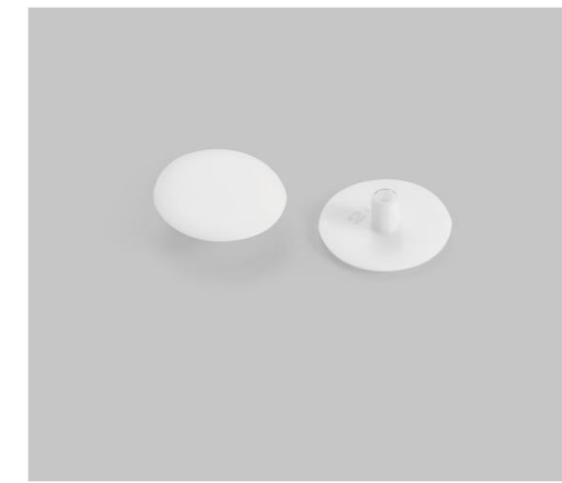

订货号 Item number	MK-KG-32-01-02
产品材质 Material	塑料 Plastic
表面处理 Finish	白色 White、哑光银 Matte silver、枪色 Gun-black

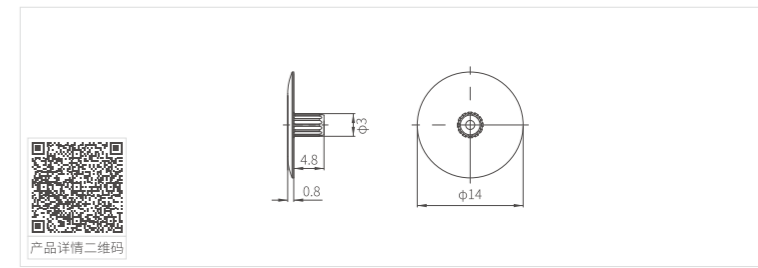

产品详情二维码

MK-KG-32-01-12 7# 12塑料盖 MK-KG-32-01-12 7# 12 Plastic cover



订货号 Item number	MK-KG-32-01-12
产品材质 Material	塑料 Plastic
表面处理 Finish	哑光银 Matte silver, 枪色 Gun-black

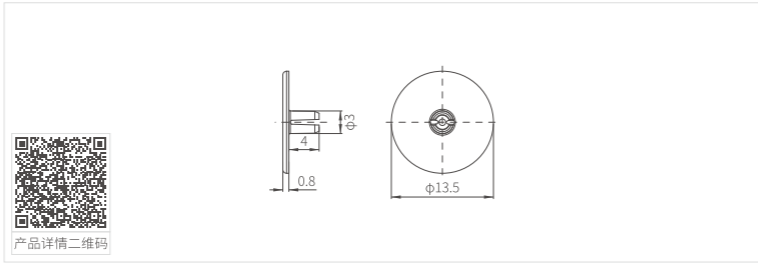

MK-KG-32-01-05 8# 10塑料盖 MK-KG-32-01-05 8# 10 Plastic cover



订货号 Item number	MK-KG-32-01-05
产品材质 Material	塑料 Plastic
表面处理 Finish	哑光银 Matte silver, 枪色 Gun-black

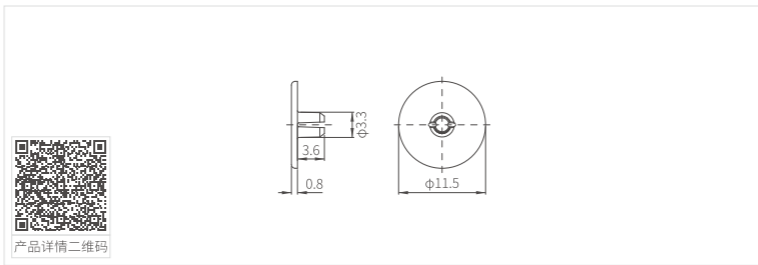

MK-KG-32-01-11 9# 11螺丝装饰盖 MK-KG-32-01-11 9# 11 Screw decorative cover



订货号 Item number	MK-KG-32-01-11
产品材质 Material	塑料 Plastic
表面处理 Finish	哑光银 Matte silver, 枪色 Gun-black

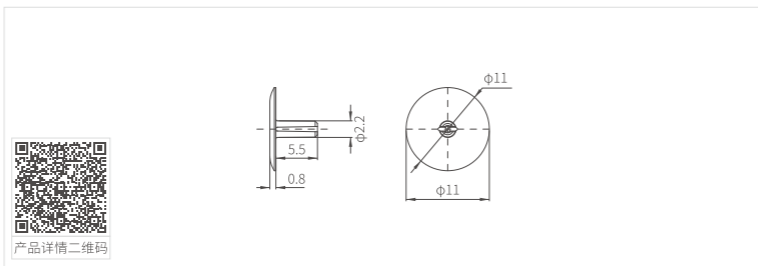



MeiKi明希®

EMBEDDED PARTS SERIES
预埋件系列

WEAR-RESISTANT, PRESSURE-RESISTANT
AND LOAD-BEARING UPGRADES
耐磨抗压 承重升级

坚固耐用, 厚薄板材皆适用
满足不同空间的个性化需求

Strong and durable, suitable for both thick and thin sheets
Meet the individual needs of different Spaces

MK-M10SZLM 四爪螺母 MK-M10SZLM T-nut



订货号 Item number	MK-M10SZLM
产品材质 Material	铁 Iron
表面处理 Finish	蓝白锌 Blue zinc

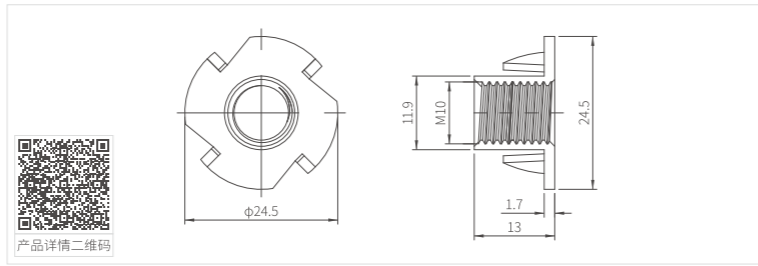

产品详情二维码

MK-M8LMLM 拉铆螺母 MK-M8LMLM Rivet nut



订货号 Item number	MK-M8LMLM
产品材质 Material	铁 Iron
表面处理 Finish	蓝白锌 Blue zinc、彩锌 Colored zinc

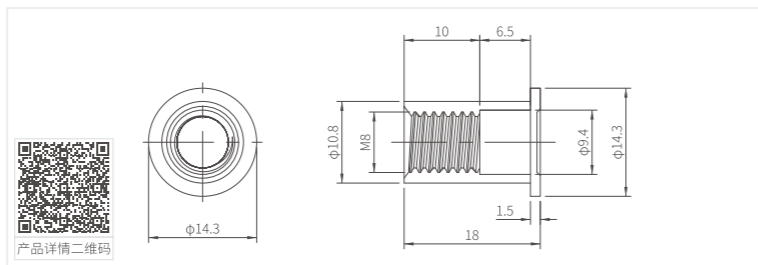

产品详情二维码

MK-Φ8TT 带边铜套 MK-Φ8TT Copper bush



订货号 Item number	MK-Φ8TT
产品材质 Material	铜 Copper
表面处理 Finish	本色 Natural color

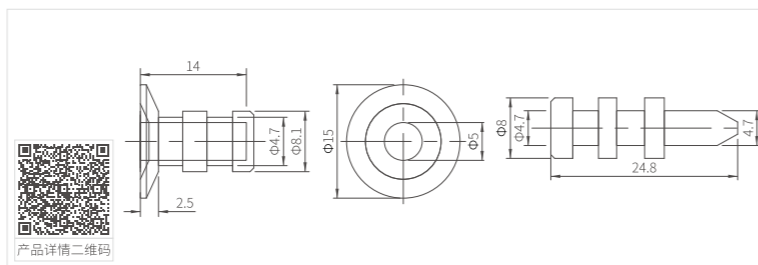

产品详情二维码

MK-M12XCZ 小床柱 MK-M12XCZ Furniture nut



订货号 Item number	MK-M12XCZ
产品材质 Material	铁 Iron
表面处理 Finish	蓝白锌 Blue zinc

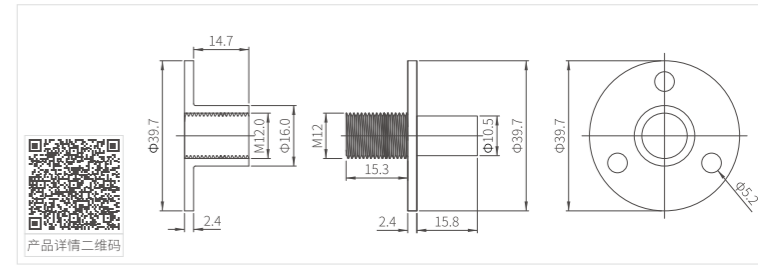

产品详情二维码

MK-M6HCLM 花齿螺母 MK-M6HCLM Flange nut



订货号 Item number	MK-M6HCLM
产品材质 Material	铁+塑料 Iron+plastic
表面处理 Finish	蓝白锌+白色 Blue zinc+white

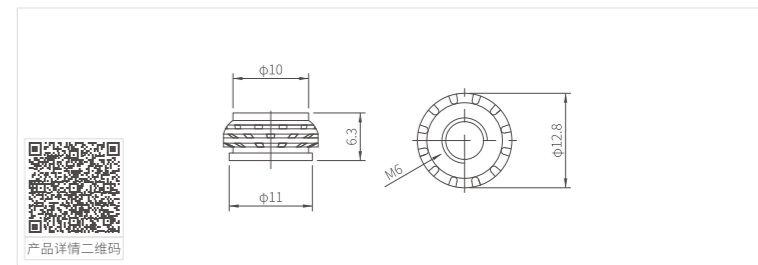

产品详情二维码

MK-CS-20-01-02 带介内外牙螺母 MK-CS-20-01-02 Insert nut type D

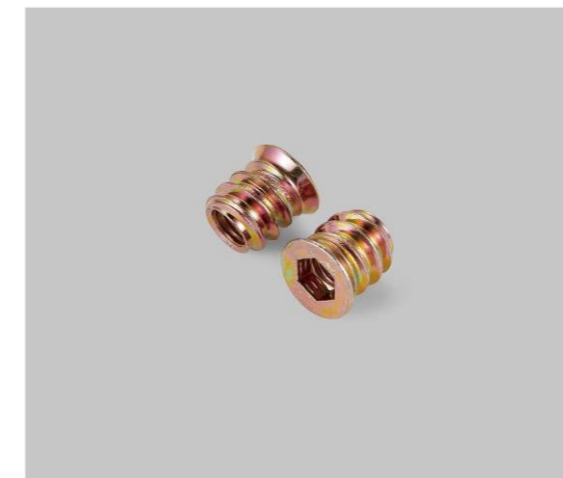

订货号 Item number	MK-CS-20-01-02
产品材质 Material	碳钢 Carbon steel
表面处理 Finish	彩锌 Colored zinc

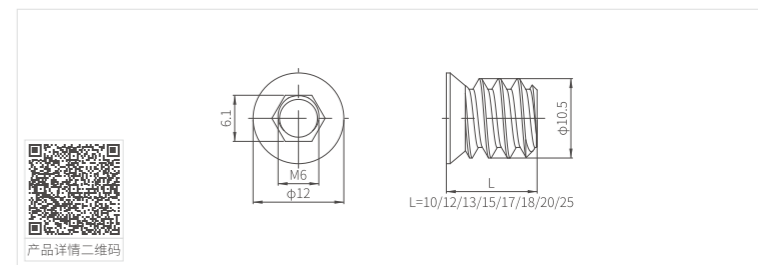

产品详情二维码

MK-CS-21-01-01 直通内外牙螺母 MK-CS-21-01-01 Insert nut type E



订货号 Item number	MK-CS-21-01-01
产品材质 Material	碳钢 Carbon steel
表面处理 Finish	彩锌 Colored zinc

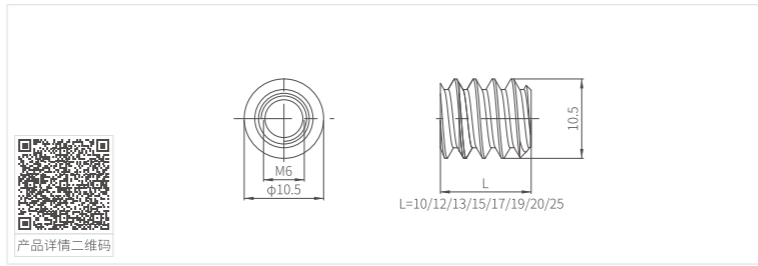

MK-CS-20-02-02 带介内外牙 MK-CS-20-02-02 Insert nut type D

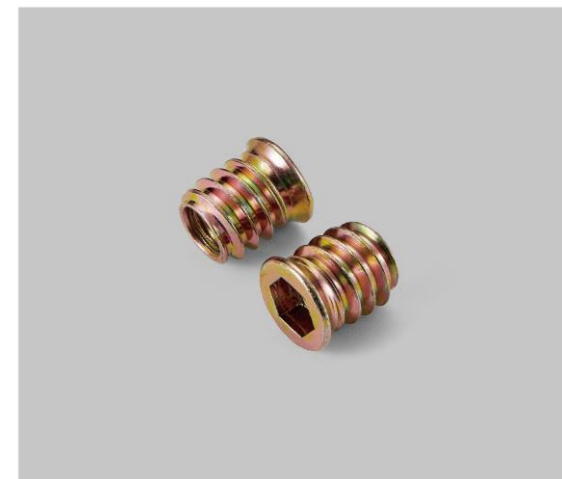

订货号 Item number	MK-CS-20-02-02
产品材质 Material	碳钢 Carbon steel
表面处理 Finish	彩锌 Colored zinc

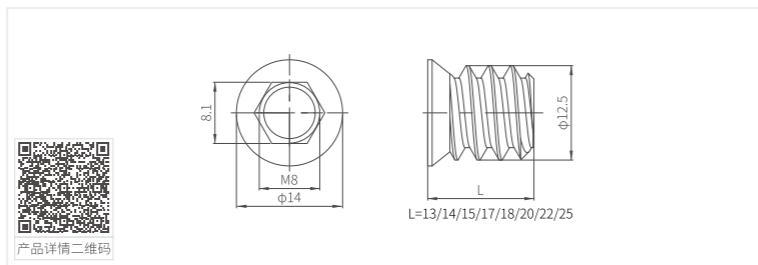

MK-CS-21-02-02 直通内外牙 MK-CS-21-02-02 Insert nut type E



订货号 Item number	MK-CS-21-02-02
产品材质 Material	碳钢 Carbon steel
表面处理 Finish	彩锌 Colored zinc

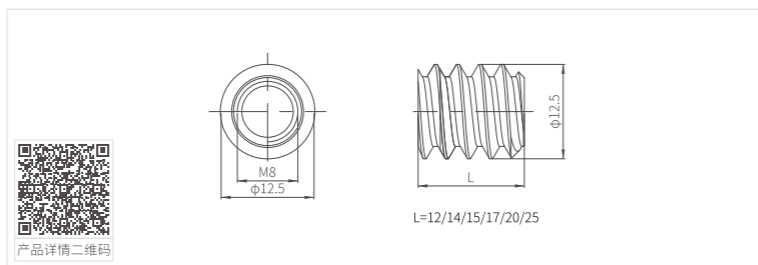

MK-TPZ-6*12 铜膨胀螺母 MK-TPZ-6*12 Copper expansion nut



订货号 Item number	MK-TPZ-6*12
产品材质 Material	铜 Copper
表面处理 Finish	本色 Natural color

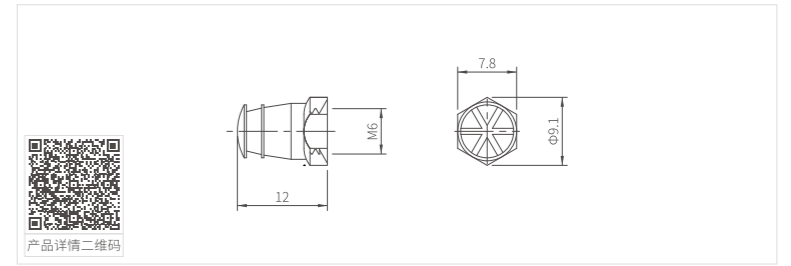

MK-6-13NWY 美制内外牙螺母 MK-6-13NWY American metric insert nut



订货号 Item number	MK-6-13NWY
产品材质 Material	锌合金 Zinc alloy
表面处理 Finish	黑色 Black, 彩锌 Colored zinc, 蓝白锌 Blue zinc

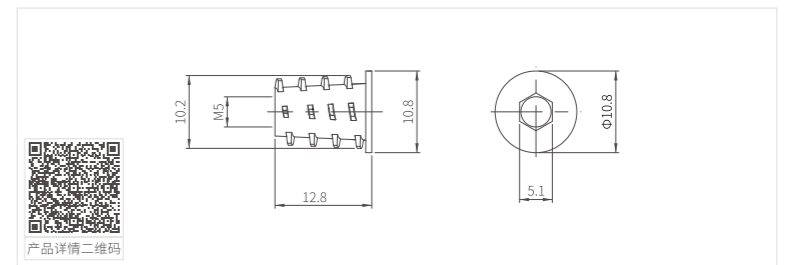

MK-4-10CM 4厘刺母 MK-4-10CM Socket nut



订货号 Item number	MK-4-10CM
产品材质 Material	锌合金 Zinc alloy
表面处理 Finish	彩锌 Colored zinc

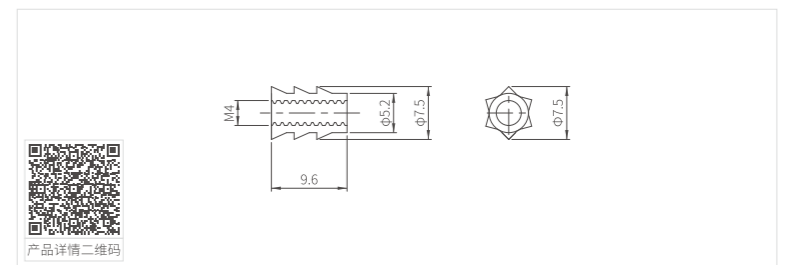

MK-ZA-51-65-12 带介内外牙螺母 MK-ZA-51-65-12 Insert nut type D



订货号 Item number	MK-ZA-51-65-12
产品材质 Material	锌合金 Zinc alloy
表面处理 Finish	彩锌 Colored zinc

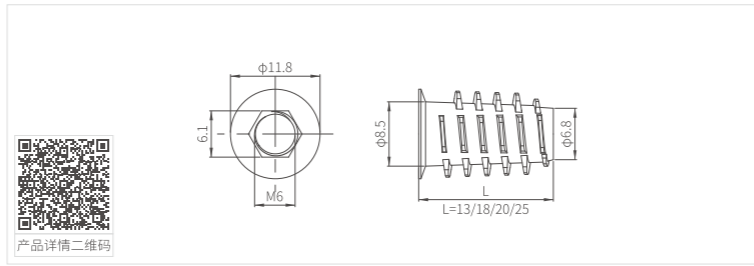

MK-ZA-51-61-12 无介内外牙螺母 MK-ZA-51-61-12 Insert nut type E

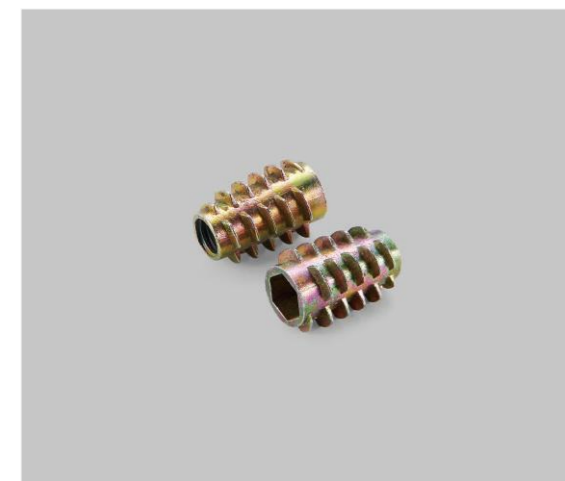

订货号 Item number	MK-ZA-51-61-12
产品材质 Material	锌合金 Zinc alloy
表面处理 Finish	彩锌 Colored zinc

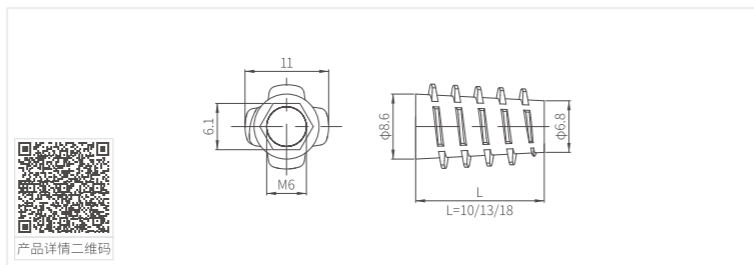

MK-ZA-51-86-17 带介内外牙螺母 MK-ZA-51-86-17 Insert nut type D

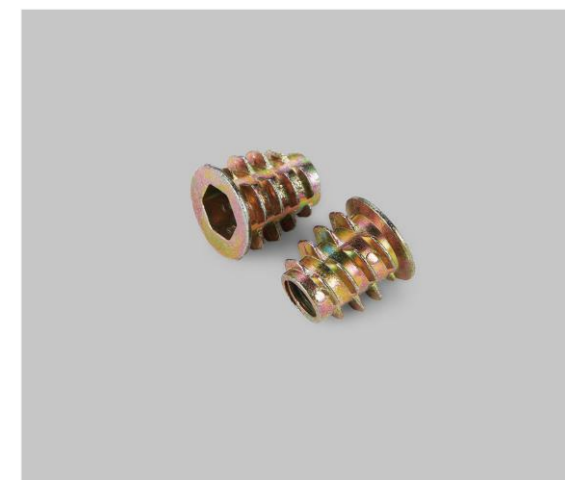

订货号 Item number	MK-ZA-51-86-17
产品材质 Material	锌合金 Zinc alloy
表面处理 Finish	彩锌 Colored zinc

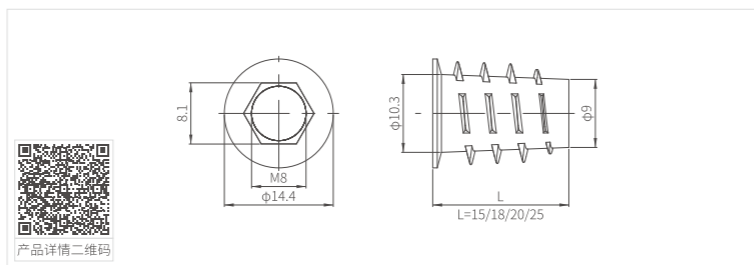

MK-ZA-51-86-18 无介内外牙螺母 MK-ZA-51-86-18 Insert nut type E

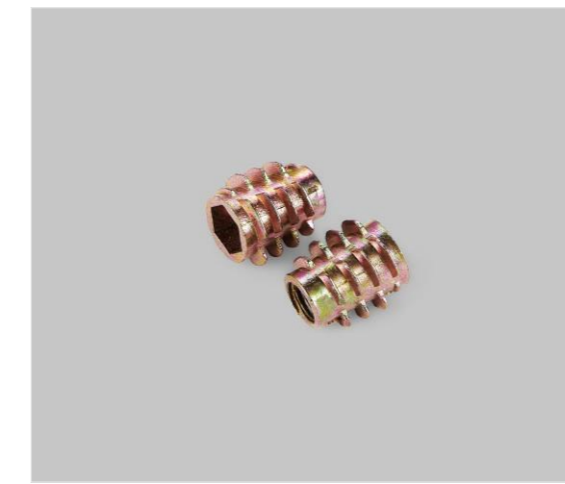

订货号 Item number	MK-ZA-51-86-18
产品材质 Material	锌合金 Zinc alloy
表面处理 Finish	彩锌 Colored zinc

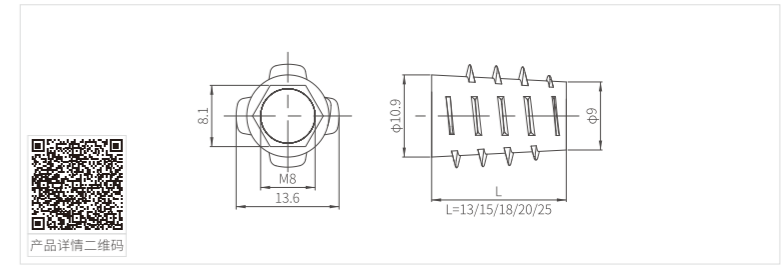

MK-ZA-52-00-08 锤头螺母 MK-ZA-52-00-08 Barrel nut



订货号 Item number	MK-ZA-52-00-08
产品材质 Material	锌合金 Zinc alloy
表面处理 Finish	彩锌 Colored zinc

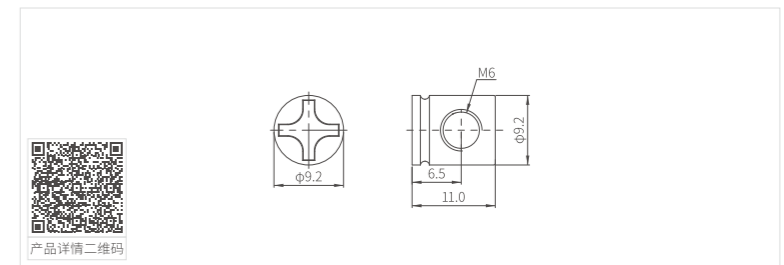

MK-ZA-52-00-14 锤头螺母 MK-ZA-52-00-14 Barrel nut

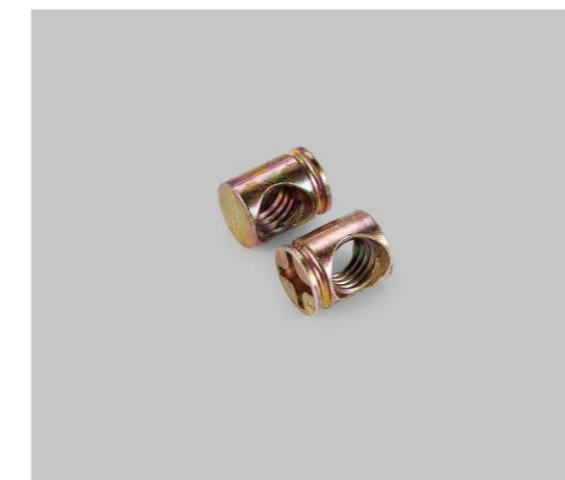

订货号 Item number	MK-ZA-52-00-14
产品材质 Material	锌合金 Zinc alloy
表面处理 Finish	彩锌 Colored zinc

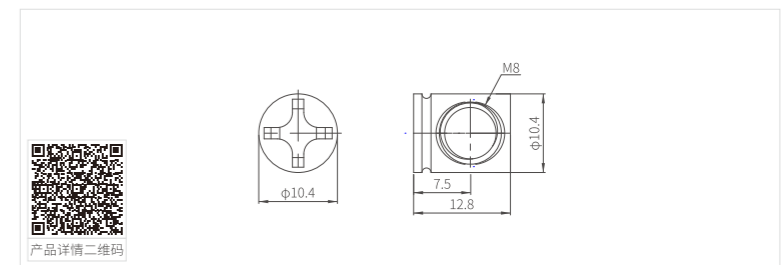

MK-ZA-DJ-8*25 大介内外牙螺母 MK-ZA-DJ-8*25 Insert Nut Type D



订货号 Item number	MK-ZA-DJ-8*25
产品材质 Material	锌合金 Zinc alloy
表面处理 Finish	彩锌 Colored zinc

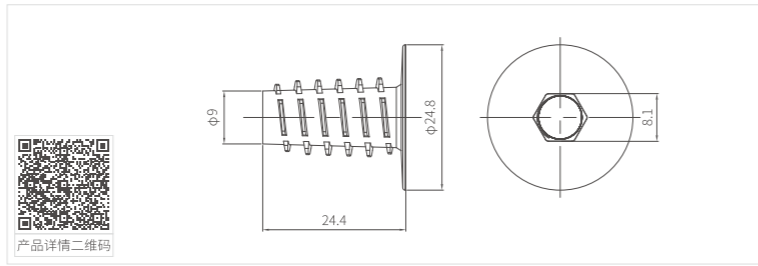

MK-5*12SLZD 连体胶塞预埋件 MK-5*12SLZD Plastic nut

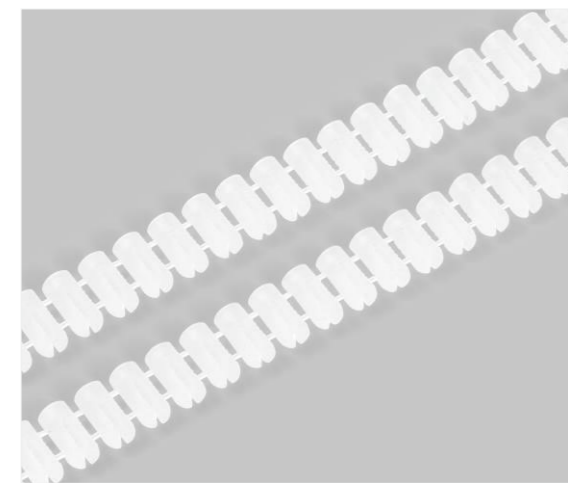

订货号 Item number	MK-5*12SLZD
产品材质 Material	塑料 Plastic
表面处理 Finish	白色 White

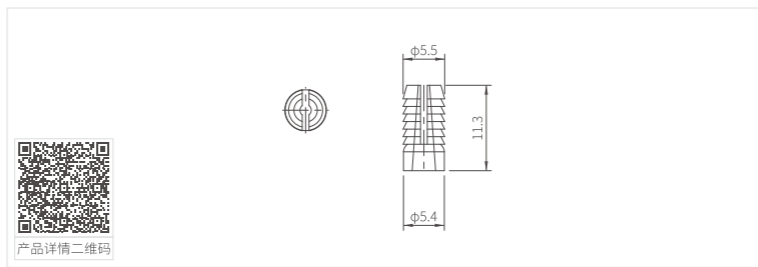

MK-8*27STJ 双头牙连接件 MK-8*27STJ Double-screw connector



订货号 Item number	MK-8*27STJ
产品材质 Material	塑料 Plastic
表面处理 Finish	白色 White

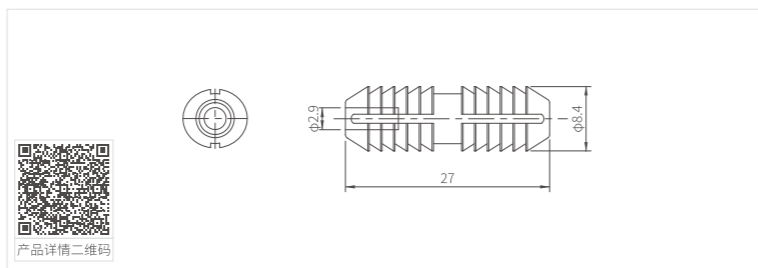

MK-6*16SXLJJ 双向连接件 MK-6*16SXLJJ Bidirectional connector



订货号 Item number	MK-6*16SXLJJ
产品材质 Material	塑料 Plastic
表面处理 Finish	白色 White

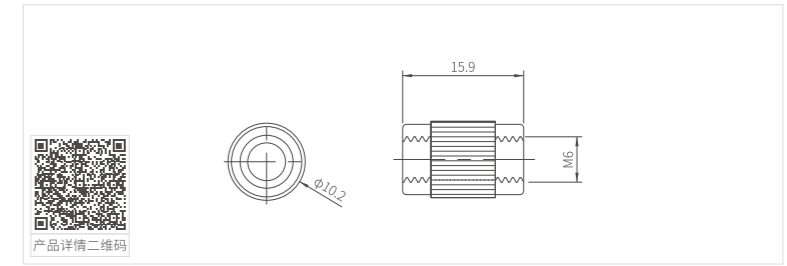

MK-YMJ-30-04-13 尼龙预埋件 MK-YMJ-30-04-13 Nylon nut



订货号 Item number	MK-YMJ-30-04-13
产品材质 Material	尼龙 Nylon
表面处理 Finish	白色 White

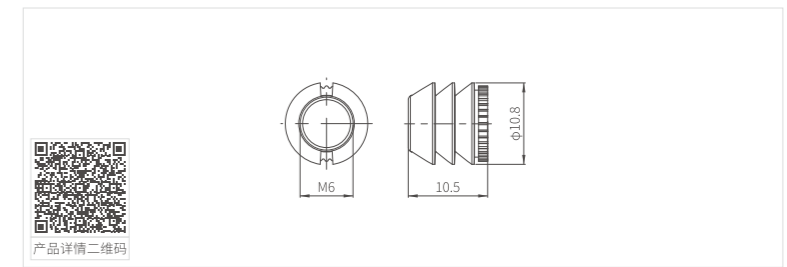

MK-YMJ-30-04-07 尼龙一字膨胀预埋件 MK-YMJ-30-04-07 Nylon nut

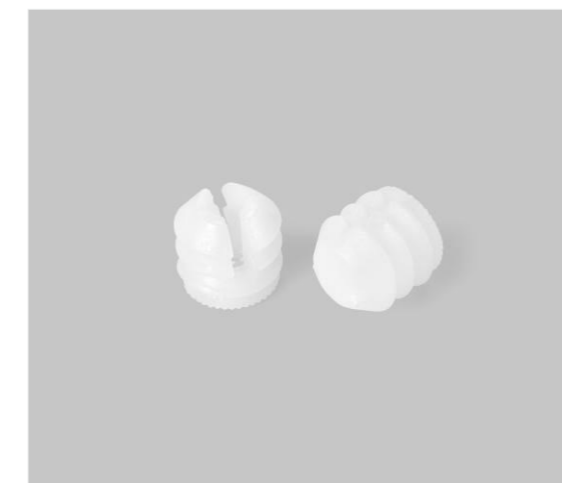

订货号 Item number	MK-YMJ-30-04-07
产品材质 Material	尼龙 Nylon
表面处理 Finish	白色 White

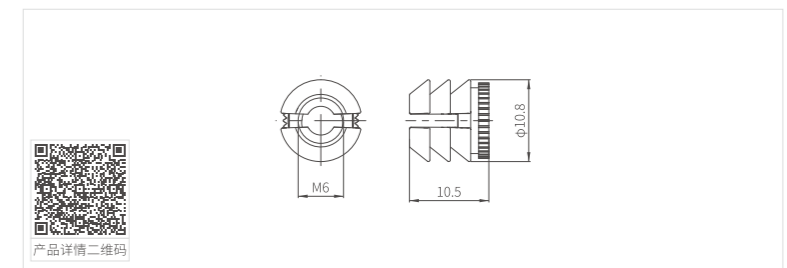

MK-YMJ-30-04-15 连排尼龙一字膨胀预埋件 MK-YMJ-30-04-15 Nylon nut

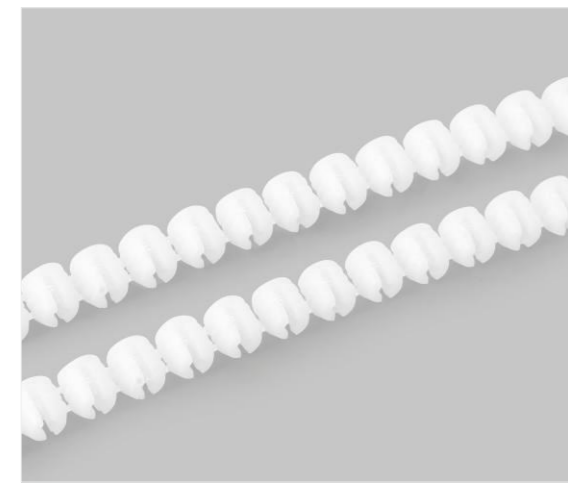

订货号 Item number	MK-YMJ-30-04-15
产品材质 Material	尼龙 Nylon
表面处理 Finish	白色 White

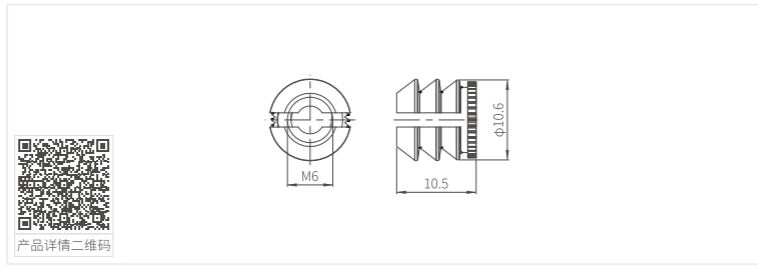

MK-YMJ-30-02-09 尼龙十字膨胀快装预埋件 MK-YMJ-30-02-09 Nylon nut



订货号 Item number	MK-YMJ-30-02-09
产品材质 Material	尼龙 Nylon
表面处理 Finish	白色 White、黑色 Black

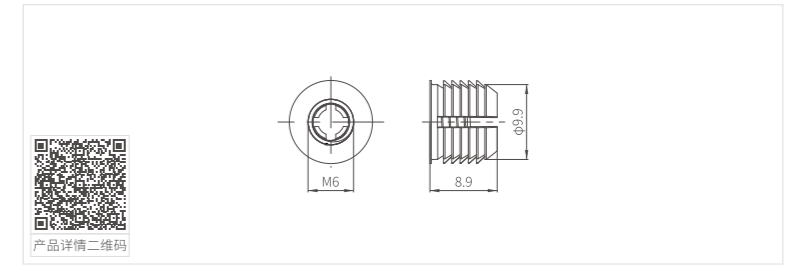

MK-YMJ-30-01-12 尼龙一字开口快装预埋件 MK-YMJ-30-01-12 Nylon nut



订货号 Item number	MK-YMJ-30-01-12
产品材质 Material	尼龙 Nylon
表面处理 Finish	白色 White、黑色 Black

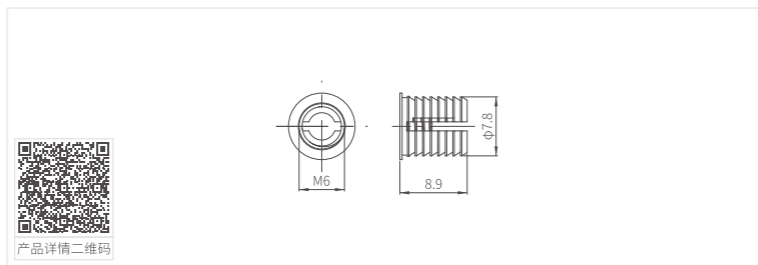

MK-YMJ-30-00-05 尼龙无牙一字膨胀预埋件 MK-YMJ-30-00-05 Nylon nut



订货号 Item number	MK-YMJ-30-00-05
产品材质 Material	尼龙 Nylon
表面处理 Finish	白色 White

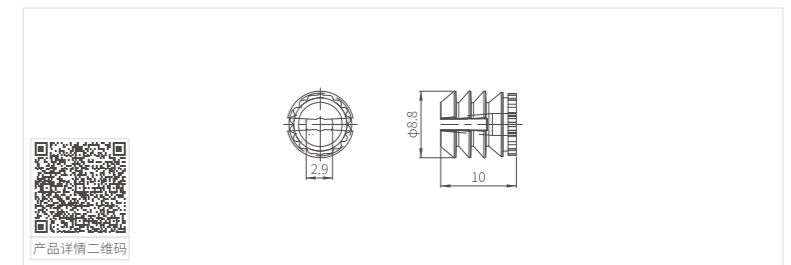

MK-YMJ-30-07-03 尼龙一字膨胀细牙快装预埋件 MK-YMJ-30-07-03 Nylon nut



订货号 Item number	MK-YMJ-30-07-03
产品材质 Material	尼龙 Nylon
表面处理 Finish	白色 White、黑色 Black

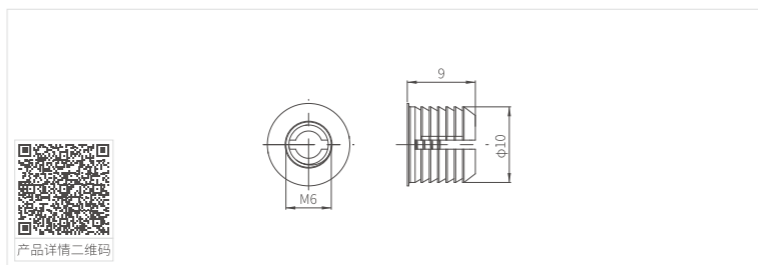

MK-YMJ-30-01-11 尼龙有牙一字膨胀预埋件 MK-YMJ-30-01-11 Nylon nut



订货号 Item number	MK-YMJ-30-01-11
产品材质 Material	尼龙 Nylon
表面处理 Finish	白色 White

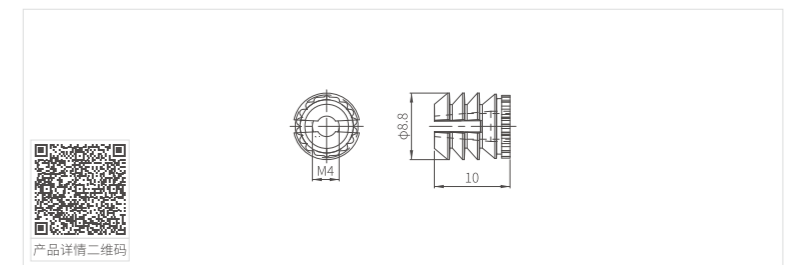

MK-PZG-30-01-50 打结膨胀管 MK-PZG-30-01-50 Expansion tube



订货号 Item number	MK-PZG-30-01-50
产品材质 Material	尼龙 Nylon
表面处理 Finish	灰色 Gray
产品规格 Specifications	8*50mm

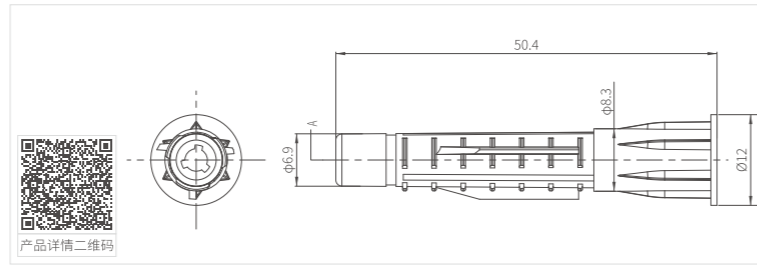

产品详情二维码

MK-PZG-30-01-30 带叉膨胀管 MK-PZG-30-01-30 Expansion tube

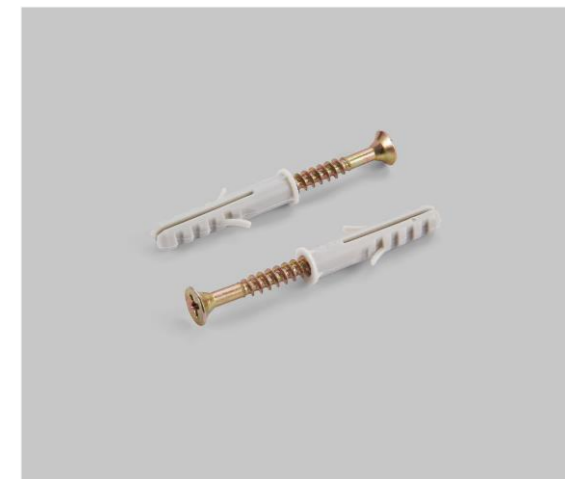

订货号 Item number	MK-PZG-30-01-30
产品材质 Material	尼龙 Nylon
表面处理 Finish	灰色 Gray
产品规格 Specifications	6*30mm

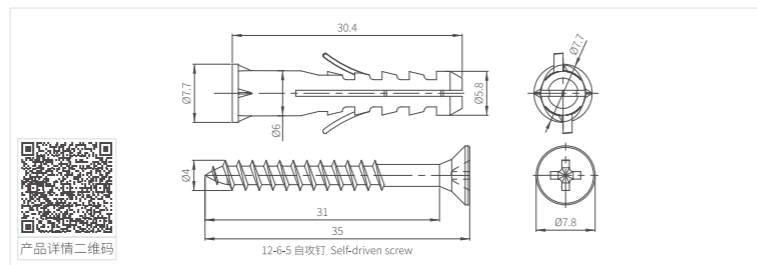

产品详情二维码

MK-PZG-CN5043 无帽打结膨胀管 MK-PZG-CN5043 Expansion tube



订货号 Item number	MK-PZG-CN5043
产品材质 Material	塑料 Plastic
表面处理 Finish	灰色 Gray
产品规格 Specifications	8*50mm

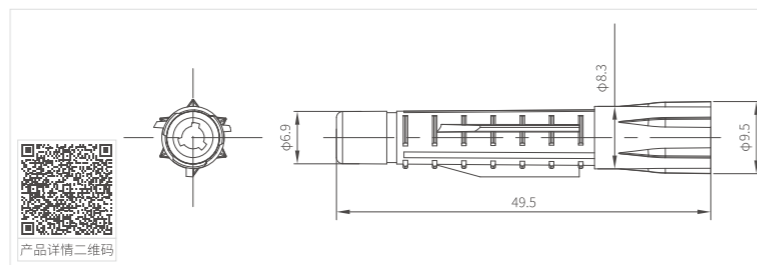

产品详情二维码

MK-PZG-CN5042 10*60打结膨胀 MK-PZG-CN5042 Expansion tube



订货号 Item number	MK-PZG-CN5042
产品材质 Material	塑料+碳钢 Plastic+Carbon steel
表面处理 Finish	灰色+彩锌 Gray+Colored zinc
产品规格 Specifications	10*60mm, 5*85mm

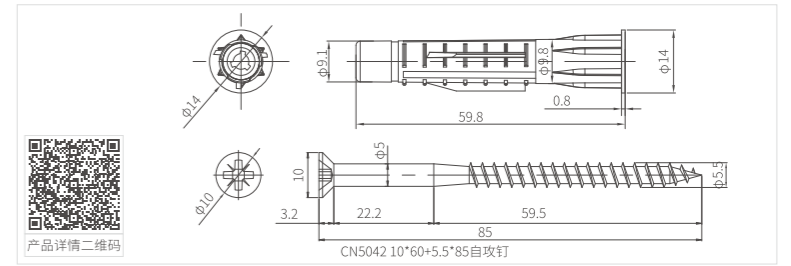

产品详情二维码

MK-PZG-CH5020 6*30 膨胀 MK-PZG-CH5020 Expansion tube

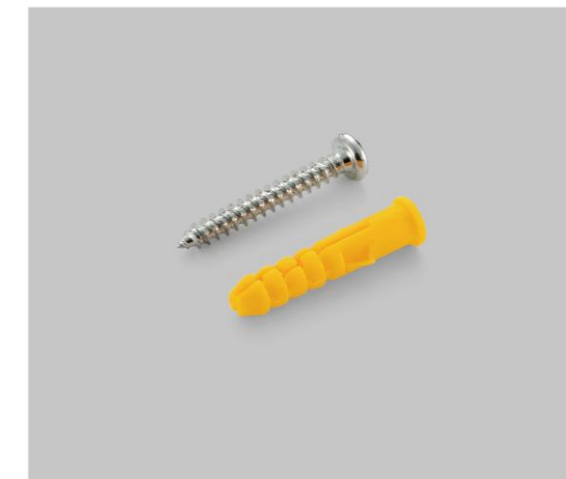

订货号 Item number	MK-PZG-CH5020
产品材质 Material	塑料+碳钢 Plastic+Carbon steel
表面处理 Finish	黄色+白锌 Yellow+White zinc
产品规格 Specifications	6*30mm, 4*30mm

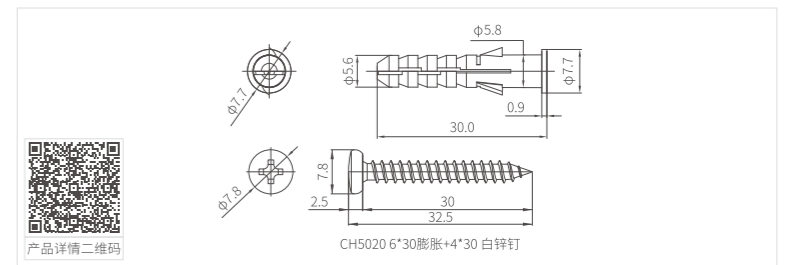

产品详情二维码

MK-PZG-CN5085 机翼膨胀管 MK-PZG-CN5085 Expansion tube



订货号 Item number	MK-PZG-CN5085
产品材质 Material	塑料 Plastic
表面处理 Finish	灰色 Gray
产品规格 Specifications	8*50mm

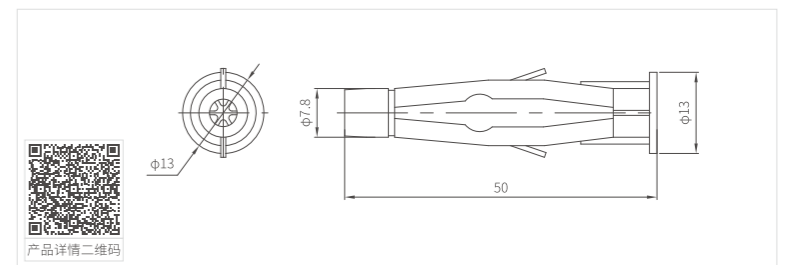

产品详情二维码

MK-PZG-CH5020C 小黄鱼膨胀管 MK-PZG-CH5020C Expansion tube

PAG
081

拆装连接件系列
Connecting fitting series



订货号 Item number	MK-PZG-CH5020C
产品材质 Material	塑料 Plastic
表面处理 Finish	黄色 Yellow
产品规格 Specifications	8*80mm

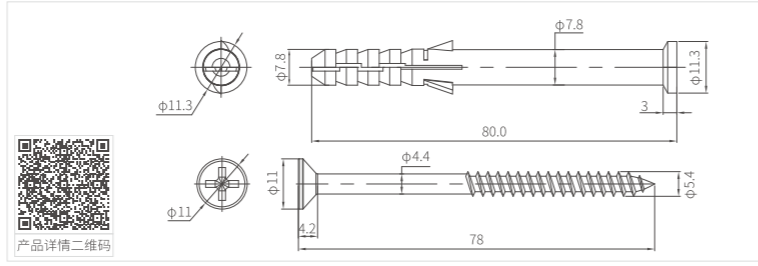

产品详情二维码





MeiKi明希®

SHELF SUPPORT SERIES
层板托系列

FLEXIBLE AND CHANGEABLE
ACHIEVE THE BEAUTY OF ORDER
灵活多变 成就秩序美

优选材质，硬度高韧性强
坚固耐用，轻松托起日常物品
Preferred material, high hardness and toughness
Rugged and easy to lift everyday items



MeiKi明希®

FLEXIBLE AND CHANGEABLE
ACHIEVE THE BEAUTY OF ORDER
灵活多变 成就秩序美

优选材质, 硬度高韧性强
坚固耐用, 轻松托起日常物品
Preferred material, high hardness and toughness
Rugged and easy to lift everyday items

MK-BT-001 层板托 MK-BT-001 Shelf support



订货号 Item number	MK-BT-001
产品材质 Material	锌合金 Zinc alloy
表面处理 Finish	镍 Nickel plating

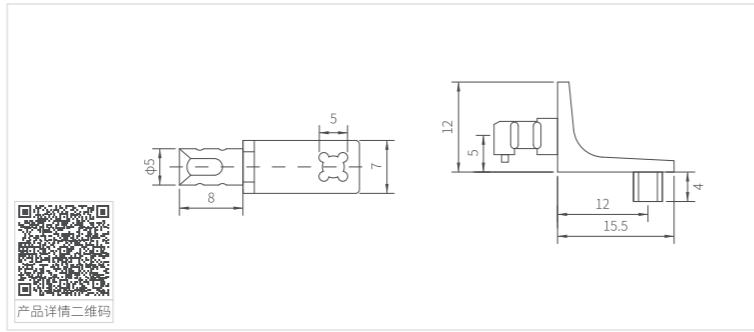

产品详情二维码

MK-BT-002 层板托 MK-BT-002 Shelf support



订货号 Item number	MK-BT-002
产品材质 Material	锌合金 Zinc alloy
表面处理 Finish	镍 Nickel plating

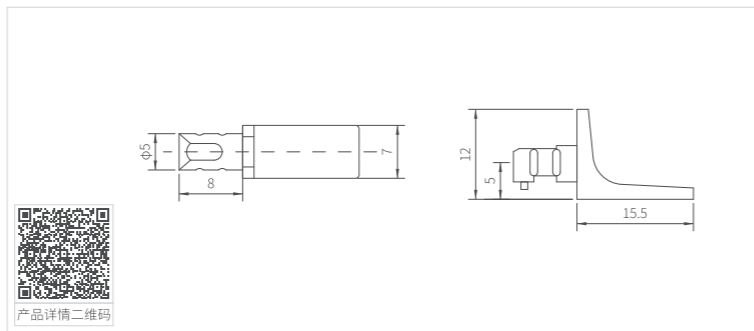

产品详情二维码

MK-BT-003 层板托 MK-BT-003 Shelf support



订货号 Item number	MK-BT-003
产品材质 Material	锌合金 Zinc alloy
表面处理 Finish	镍 Nickel plating

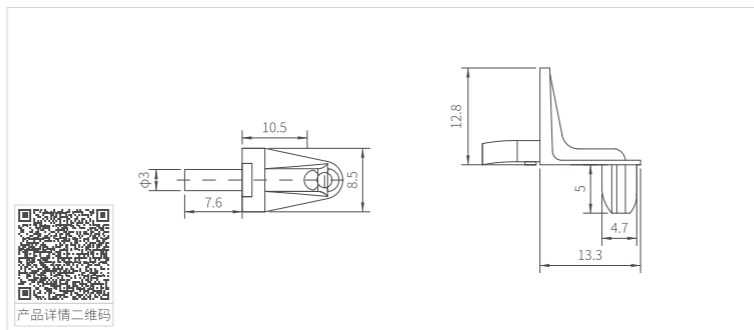

产品详情二维码

MK-BT-040200 层板托 MK-BT-040200 Shelf support



订货号 Item number	MK-BT-040200
产品材质 Material	锌合金+塑料 Zinc alloy+Plastic
表面处理 Finish	镍 Nickel plating

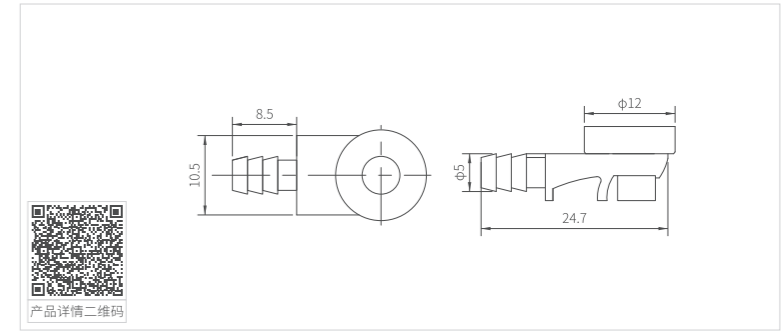

产品详情二维码

MK-BT-004 层板托 MK-BT-004 Shelf support



订货号 Item number	MK-BT-004
产品材质 Material	锌合金+塑料 Zinc alloy+Plastic
表面处理 Finish	镍 Nickel plating

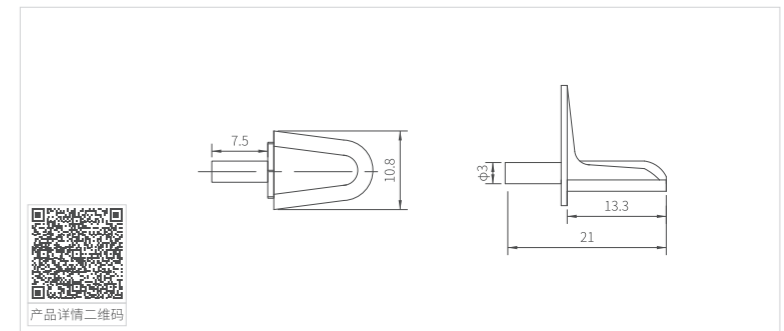

产品详情二维码

MK-BT-040500 层板托 MK-BT-040500 Shelf support



订货号 Item number	MK-BT-040500
产品材质 Material	锌合金 Zinc alloy
表面处理 Finish	镍 Nickel plating

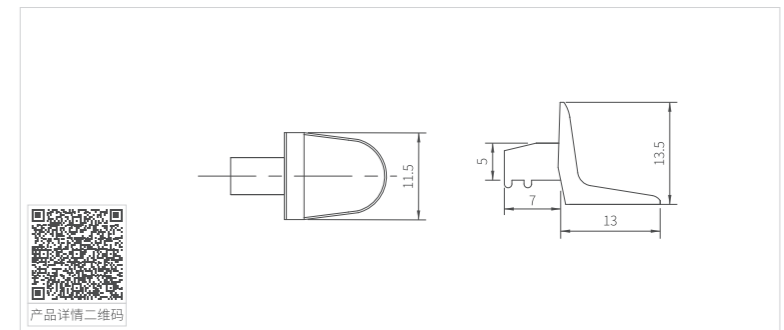

产品详情二维码

MK-BT-040100 层板托 MK-BT-040100 Shelf support



订货号 Item number	MK-BT-040100
产品材质 Material	锌合金 Zinc alloy
表面处理 Finish	镍 Nickel plating

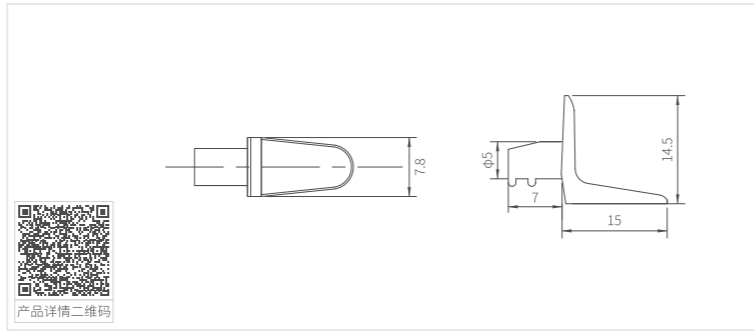

MK-BT-040700 层板托 MK-BT-040700 Shelf support



订货号 Item number	MK-BT-040700
产品材质 Material	锌合金+塑料 Zinc alloy+Plastic
表面处理 Finish	镍 Nickel plating

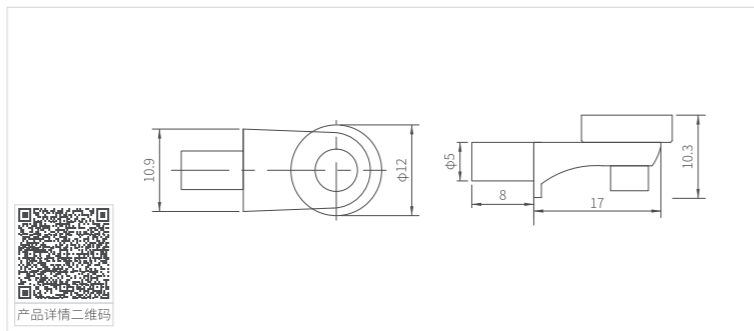

MK-BT-042600 层板托 MK-BT-042600 Shelf support



订货号 Item number	MK-BT-042600
产品材质 Material	锌合金 Zinc alloy
表面处理 Finish	镍 Nickel plating

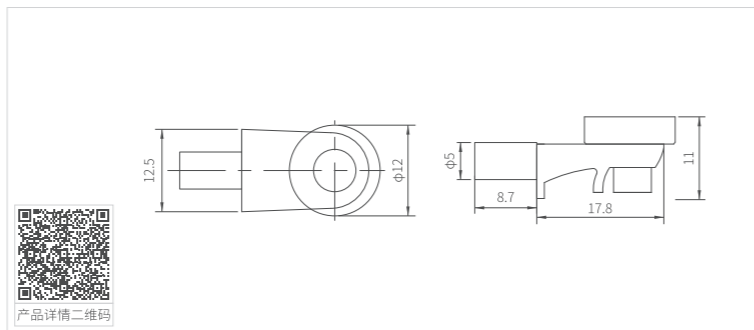

MK-LBBT-3# 乳白层板托 MK-LBBT-3# Milky white shelf support



订货号 Item number	MK-LBBT-3#
产品材质 Material	塑料+铁 Plastic+iron
表面处理 Finish	白色 White

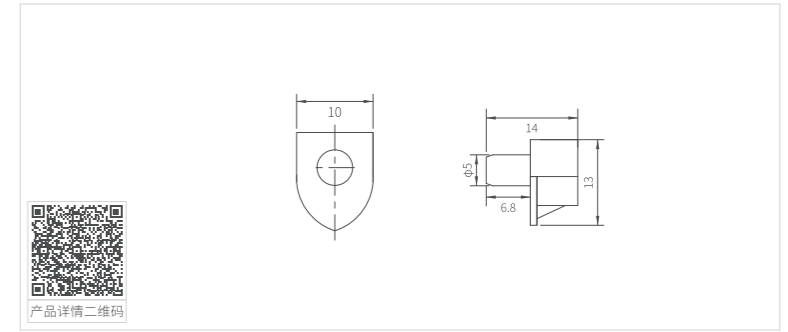

MK-TMBT-1# 透明层板托 MK-TMBT-1# Transparent shelf support



订货号 Item number	MK-TMBT-1#
产品材质 Material	塑料+铁 Plastic+iron
表面处理 Finish	半透明 Translucent

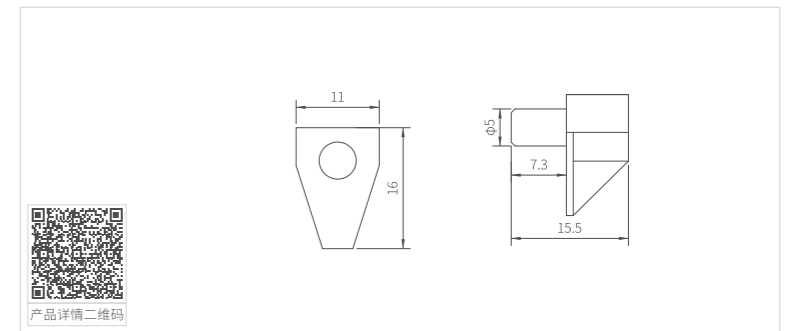

MK-MNCBT-31-01-01 迷你层板托 MK-MNCBT-31-01-01 Shelf support



订货号 Item number	MK-MNCBT-31-01-01
产品材质 Material	塑料 Plastic
产品颜色 Finish	米白 Creamy white、灰色 Gray
板托螺丝配件可选 Optional screw	13-2-1、13-2-2

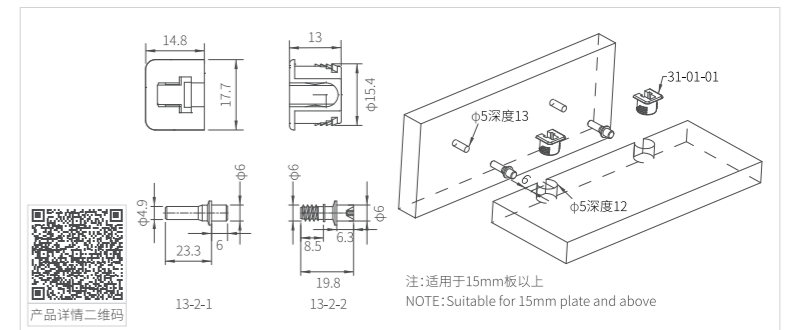

MK-CBT-31-02-04 方形滑盖层板托 MK-CBT-31-02-04 Shelf support



订货号 Item number	MK-CBT-31-02-04
产品材质 Material	碳钢+塑料 Carbon steel+plastic
产品颜色 Finish	白色 White、黑色 Black

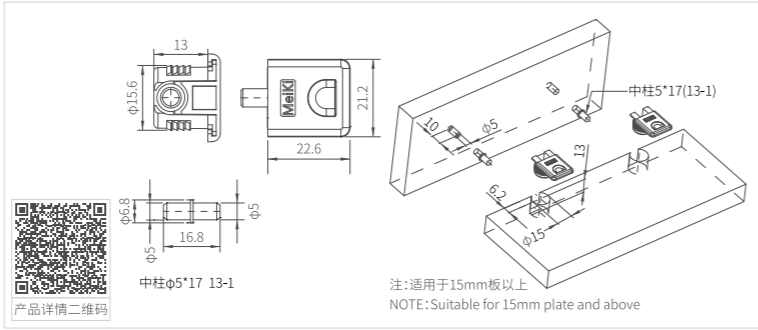

MK-CBT-31-02-02 长方形滑盖层板托 MK-CBT-31-02-02 Shelf support



订货号 Item number	MK-CBT-31-02-02
产品材质 Material	碳钢+塑料 Carbon steel+plastic
产品颜色 Finish	白色 White、黑色 Black

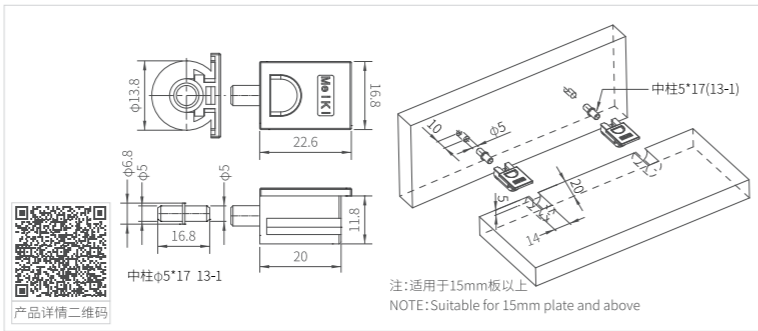

MK-CBT-54-00-19 36#层板托 MK-CBT-54-00-19 36 Shelf support



订货号 Item number	MK-CBT-54-00-19
产品材质 Material	锌合金 Zinc alloy
表面处理 Finish	镍 Nickel plating

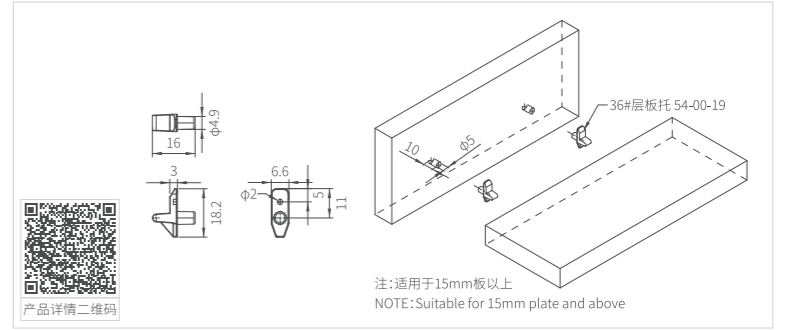

MK-CBT-54-00-08 乒乓隔板钉 MK-CBT-54-00-08 Shelf support



订货号 Item number	MK-CBT-54-00-08
产品材质 Material	锌合金 Zinc alloy
表面处理 Finish	镍 Nickel plating

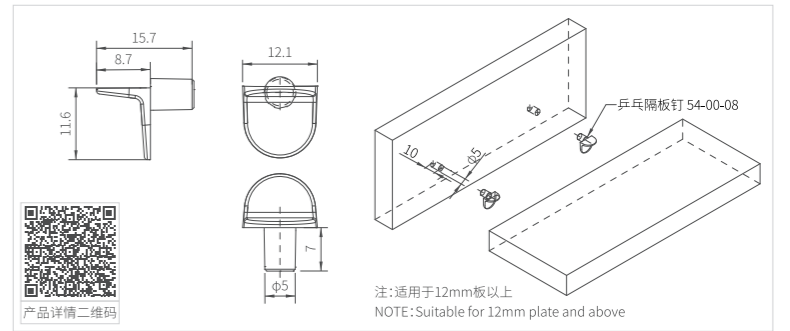

MK-CBT-54-00-15 30#层板托 MK-CBT-54-00-15 30 Shelf support



订货号 Item number	MK-CBT-54-00-15
产品材质 Material	锌合金 Zinc alloy
表面处理 Finish	镍 Nickel plating

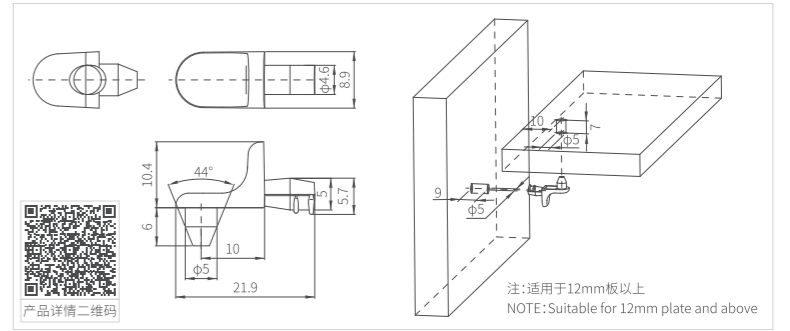

MK-CBT-54-00-11 12半圆层板托(膨胀管) MK-CBT-54-00-11 12 Shelf support



订货号 Item number	MK-CBT-54-00-11
产品材质 Material	锌合金+塑料 Zinc alloy+plastic
表面处理 Finish	镍 Nickel plating, 枪色 Gun-black, 灰色 Gray

注:适用于18mm板以上
NOTE: Suitable for 18mm plate and above

MK-CBT-54-00-13 12半圆层板托(木牙) MK-CBT-54-00-13 12 Shelf support



订货号 Item number	MK-CBT-54-00-13
产品材质 Material	锌合金+塑料 Zinc alloy+plastic
表面处理 Finish	镍 Nickel plating, 枪色 Gun-black, 灰色 Gray

注:适用于18mm板以上
NOTE: Suitable for 18mm plate and above

MK-CBT-54-00-14 10半圆层板托(膨胀管) MK-CBT-54-00-14 10 Shelf support



订货号 Item number	MK-CBT-54-00-14
产品材质 Material	锌合金+塑料 Zinc alloy+plastic
表面处理 Finish	镍 Nickel plating, 枪色 Gun-black, 灰色 Gray

注:适用于15mm板以上
NOTE: Suitable for 15mm plate and above

MK-CBT-54-00-18 10半圆层板托(木牙) MK-CBT-54-00-18 10 Shelf support



订货号 Item number	MK-CBT-54-00-18
产品材质 Material	锌合金+塑料 Zinc alloy+plastic
表面处理 Finish	镍 Nickel plating, 枪色 Gun-black, 灰色 Gray

注:适用于15mm板以上
NOTE: Suitable for 15mm plate and above

MK-FGCBT-13-1 翻盖层板托 MK-FGCBT-13-1 Shelf support



订货号 Item number	MK-FGCBT-13-1
产品材质 Material	碳钢+塑料 Carbon+plastic
表面处理 Finish	米白 Creamy white, 灰色 Gray

注:适用于15mm板以上
NOTE: Suitable for 15mm plate and above

MK-CBT-31-01-08 白铝锌层板托 MK-CBT-31-01-08 Shelf support



订货号 Item number	MK-CBT-31-01-08
产品材质 Material	锌合金+塑料 Zinc alloy+plastic
表面处理 Finish	蓝白锌 Blue zinc, 白色 White

注:适用于15mm板以上
NOTE: Suitable for 15mm plate and above

MK-CBT-54-00-48 双孔层板托(金属) MK-CBT-54-00-48 Shelf support



订货号 Item number	MK-CBT-54-00-48
产品材质 Material	锌合金 Zinc alloy
表面处理 Finish	镍 Nickel plating

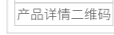
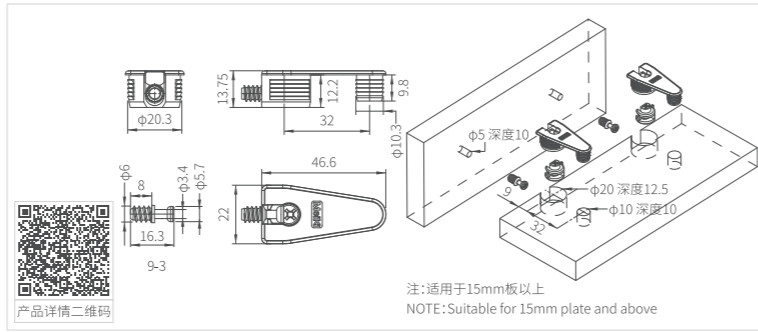

MK-CBT-31-01-07 双孔层板托(塑料) MK-CBT-31-01-07 Shelf support



订货号 Item number	MK-CBT-31-01-07
产品材质 Material	锌合金+塑料 Zinc alloy+plastic
表面处理 Finish	镍 Nickel plating, 白色 White

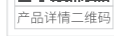
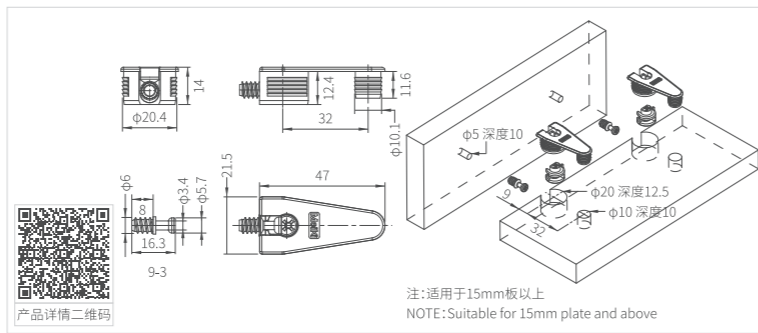

MK-CBT-31-01-15 小滑入式层板托(全通) MK-CBT-31-01-15 Shelf support



订货号 Item number	MK-CBT-31-01-15
产品材质 Material	塑料 Plastic
表面处理 Finish	白色 White

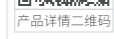
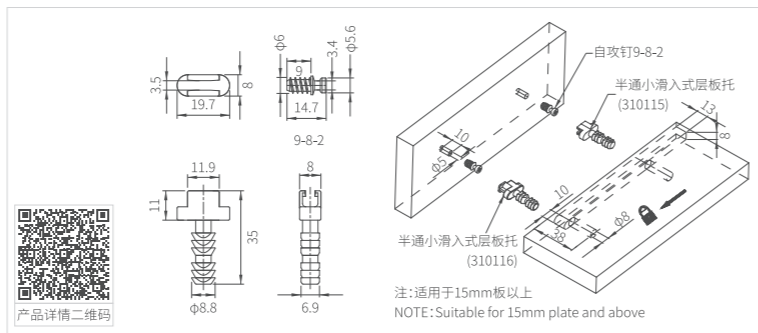

MK-CBT-31-01-16 小滑入式层板托(半通) MK-CBT-31-01-16 Shelf support



订货号 Item number	MK-CBT-31-01-16
产品材质 Material	塑料 Plastic
表面处理 Finish	白色 White

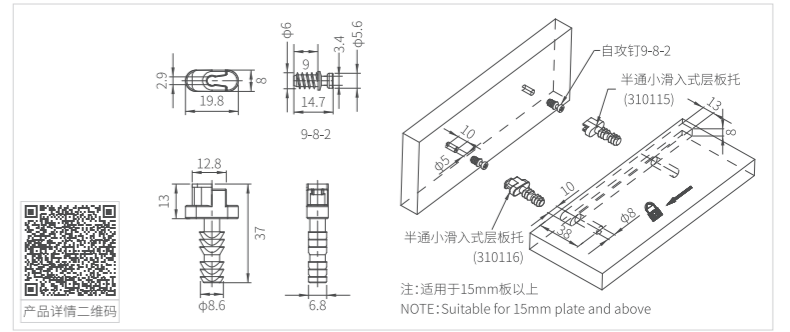

MK-CBT-31-01-13 中滑入式层板托(全通) MK-CBT-31-01-13 Shelf support



订货号 Item number	MK-CBT-31-01-13
产品材质 Material	塑料 Plastic
表面处理 Finish	白色 White

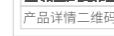
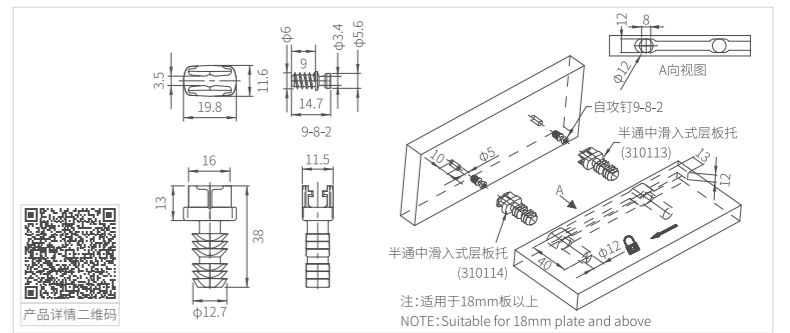

MK-CBT-31-01-14 中滑入式层板托(半通) MK-CBT-31-01-14 Shelf support



订货号 Item number	MK-CBT-31-01-14
产品材质 Material	塑料 Plastic
表面处理 Finish	白色 White

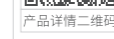
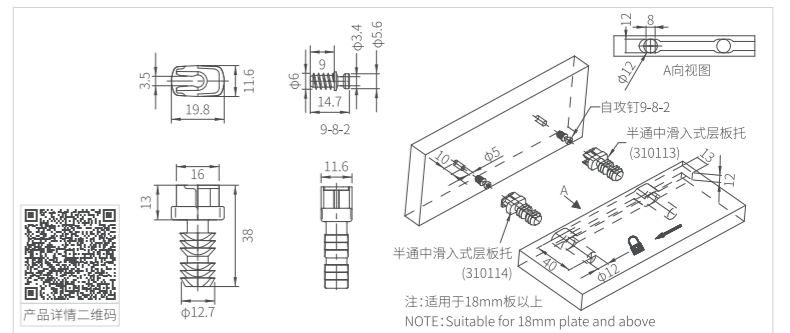

MK-YXLJ-34-01-02 0833隐形连接件 MK-YXLJ-34-01-02 Invisible connector



订货号 Item number	MK-YXLJ-34-01-02
产品材质 Material	碳钢+塑料 Carbon steel+Plastic
表面处理 Finish	黑色 Black

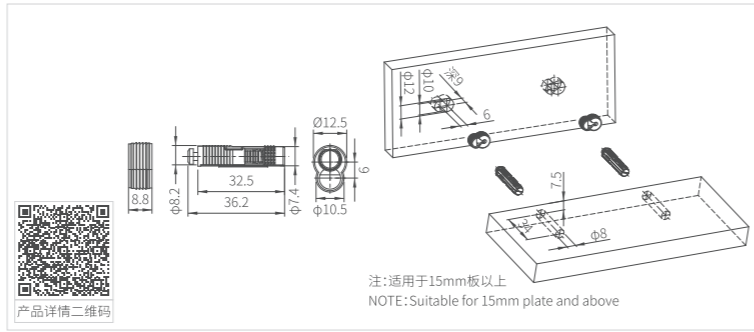

MK-TMBT-31-01-28 33#透明层板托 MK-TMBT-31-01-28 Transparent Shelf Support



订货号 Item number	MK-TMBT-31-01-28
产品材质 Material	ABS+铁 ABS+Iron
表面处理 Finish	透明+蓝白锌 Translucent+Blue zinc

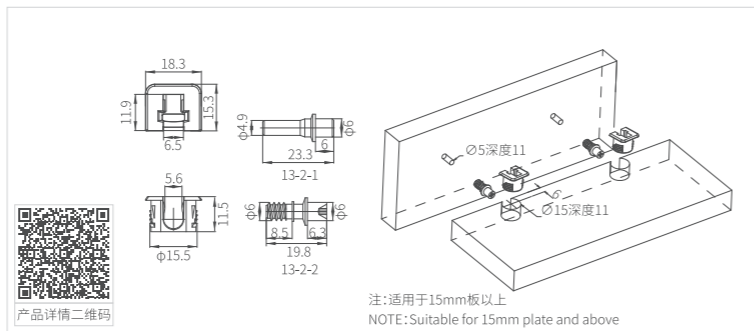

MK-KGCBT-32-02-06 扣盖层板托 MK-KGCBT-32-02-06 Snap-on Shelf Support



订货号 Item number	MK-KGCBT-32-02-06
产品材质 Material	ABS+铁 ABS+Iron
表面处理 Finish	白色+蓝白锌 White+Blue zinc

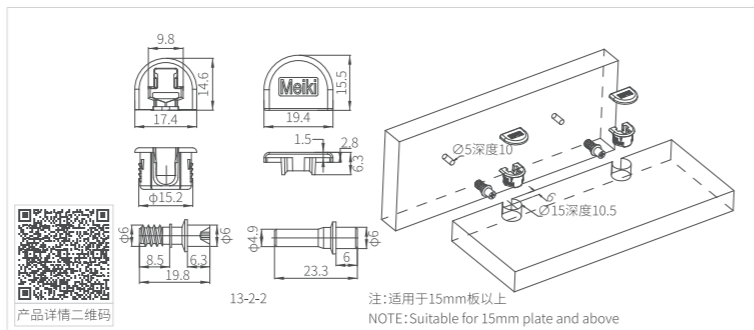

MK-SD-GBZJ-10 10厘4寸隐藏式隔板铁支架 MK-SD-GBZJ-10 10mm 4inch iron shelf support



订货号 Item number	MK-SD-GBZJ-10
产品材质 Material	铁 Iron
表面处理 Finish	镍 Nickel plating

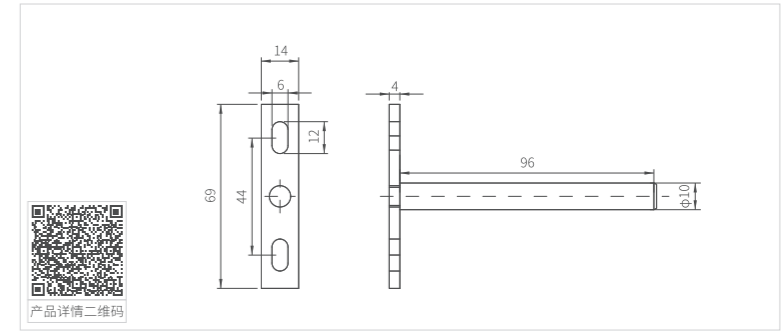

MK-GH-GBT-10-100 Ø10*100一字隐藏隔板膨胀支撑架 MK-GH-GBT-10-100 Ø10*100 Shelf support



订货号 Item number	MK-GH-GBT-10-100
产品材质 Material	铁+塑料 Iron+plastic
表面处理 Finish	棕色 Brown

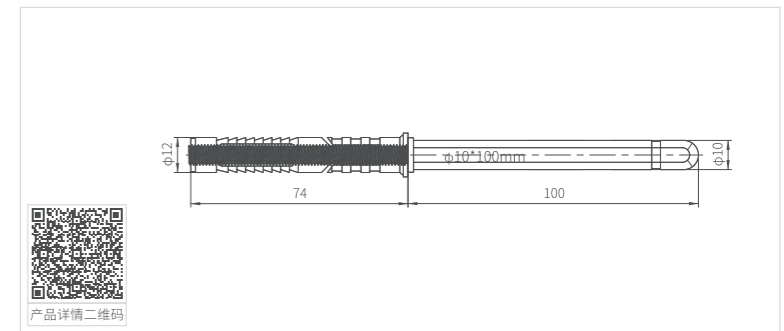

MK-SD-GBZJ-16 8寸16厘锌合金可调隐藏式隔板支架 MK-SD-GBZJ-16 8inch 16mm zinc alloy shelf support



订货号 Item number	MK-SD-GBZJ-16
产品材质 Material	锌合金 Zinc alloy
表面处理 Finish	镀锌 Zinc plating

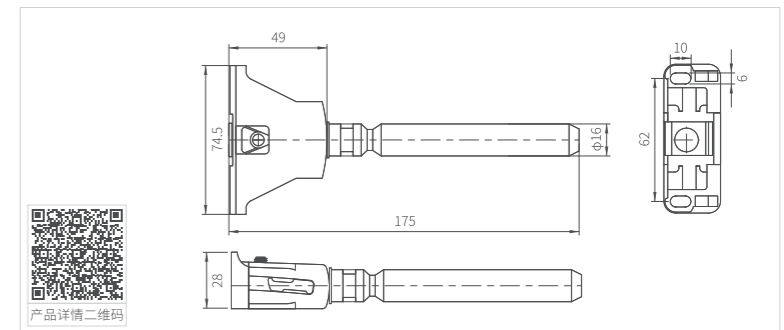

MeiKi明希®

GLASS CLIP SERIES
玻璃夹系列

EXQUISITE FASHION EXQUISITE LIFE
精巧时尚 精致生活

锌合金材质, 防锈升级
以精湛工艺实现对轻奢家居的偏爱
Zinc alloy material, anti-rust upgrade
With exquisite technology to achieve the light luxury home preference

MK-BLJ-63-57-01 1#玻璃夹 MK-BLJ-63-57-01 Glass clip



订货号 Item number	MK-BLJ-63-57-01
产品材质 Material	锌合金+PVC Zinc alloy+PVC
表面处理 Finish	枪黑 Gun black、镀铬 Chromate plating
适配玻璃厚度 Applicable Thickness	6-8mm

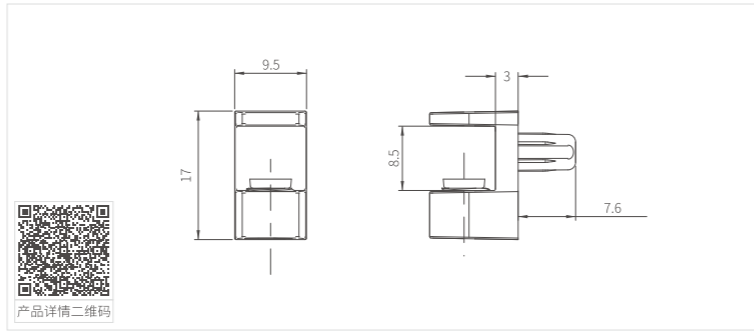

MK-BLJ-63-57-02 2#玻璃夹 MK-BLJ-63-57-02 Glass clip



订货号 Item number	MK-BLJ-63-57-02
产品材质 Material	锌合金+PVC Zinc alloy+PVC
表面处理 Finish	枪黑 Gun black、镀铬 Chromate plating
适配玻璃厚度 Applicable Thickness	6-8mm

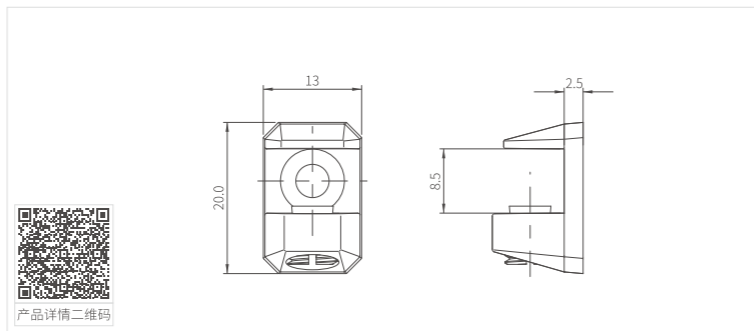

MK-BLJ-63-57-03 3#玻璃夹 MK-BLJ-63-57-03 Glass clip



订货号 Item number	MK-BLJ-63-57-03
产品材质 Material	锌合金+PVC Zinc alloy+PVC
表面处理 Finish	枪黑 Gun black、镀铬 Chromate plating
适配玻璃厚度 Applicable Thickness	6-8mm

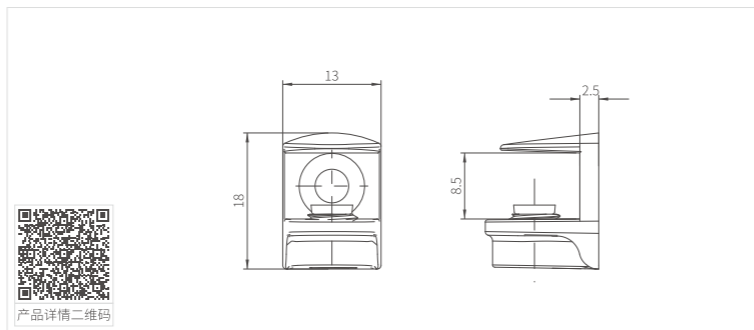

MK-BLJ-63-57-04 4#玻璃夹 MK-BLJ-63-57-04 Glass clip



订货号 Item number	MK-BLJ-63-57-04
产品材质 Material	锌合金+PVC Zinc alloy+PVC
表面处理 Finish	枪黑 Gun black、镀铬 Chromate plating
适配玻璃厚度 Applicable Thickness	6-8mm

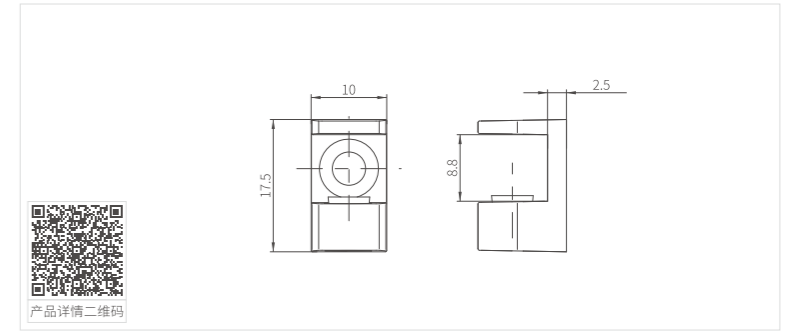

MK-BLJ-53-00-34 玻璃夹 MK-BLJ-53-00-34 Glass clip



订货号 Item number	MK-BLJ-53-00-34
产品材质 Material	锌合金+PVC Zinc alloy+PVC
表面处理 Finish	镍 Nickel plating

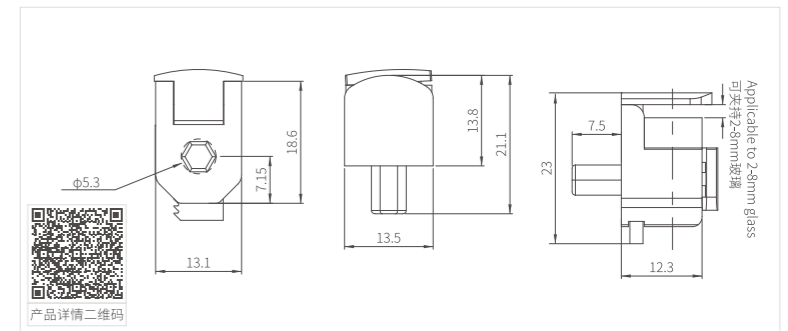

MK-BLJ-63-57-38 玻璃夹 MK-BLJ-63-57-38 Glass clip



订货号 Item number	MK-BLJ-63-57-38
产品材质 Material	锌合金+塑料 Zinc alloy+plastic
表面处理 Finish	镍 Nickel plating

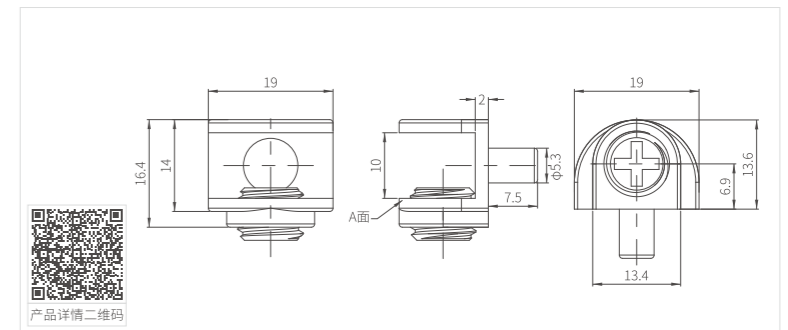

MK-BLJ-63-57-59 小银玻璃夹 MK-BLJ-63-57-59 Glass clip



订货号 Item number	MK-BLJ-63-57-59
产品材质 Material	锌合金+塑料 Zinc alloy+plastic
表面处理 Finish	镍 Nickel plating

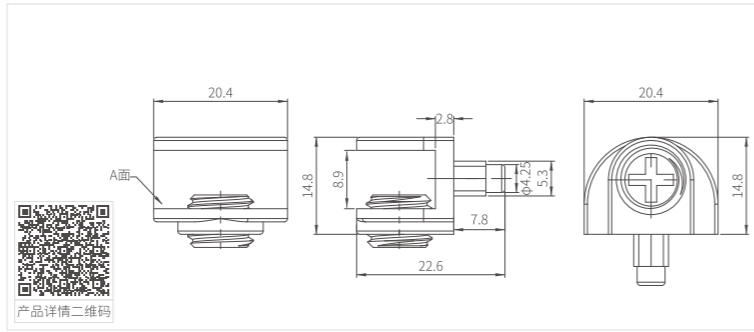

MK-WYT-036 玻璃夹 MK-WYT-036 Glass clip

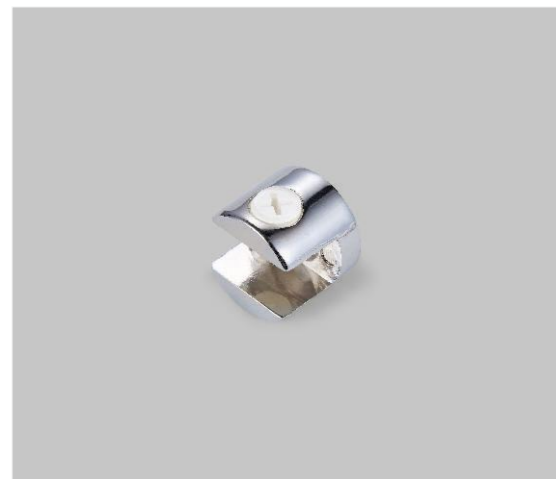

订货号 Item number	MK-WYT-036
产品材质 Material	锌合金 Zinc alloy
表面处理 Finish	亮铬 Bright chrome

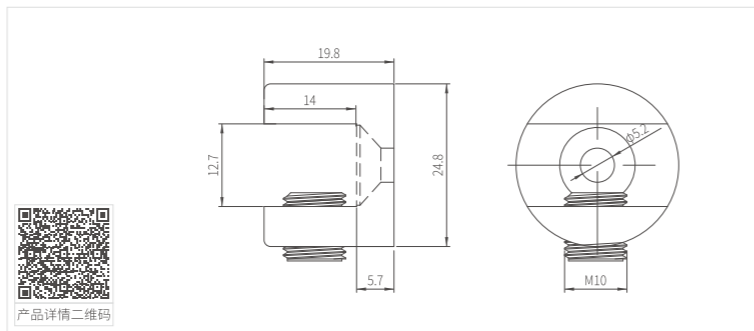

MK-WYT-044 玻璃夹 MK-WYT-044 Glass clip



订货号 Item number	MK-WYT-044
产品材质 Material	锌合金 Zinc alloy
表面处理 Finish	亮铬 Bright chrome

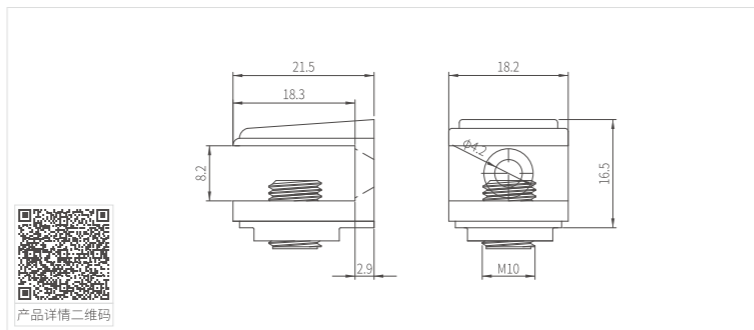

MK-WYT-D036 玻璃夹 MK-WYT-D036 Glass clip



订货号 Item number	MK-WYT-D036
产品材质 Material	锌合金 Zinc alloy
表面处理 Finish	亮铬 Bright chrome

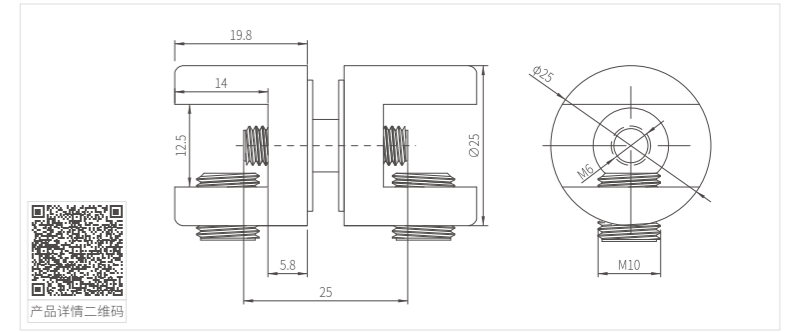

MK-WYT-043 玻璃夹 MK-WYT-043 Glass clip

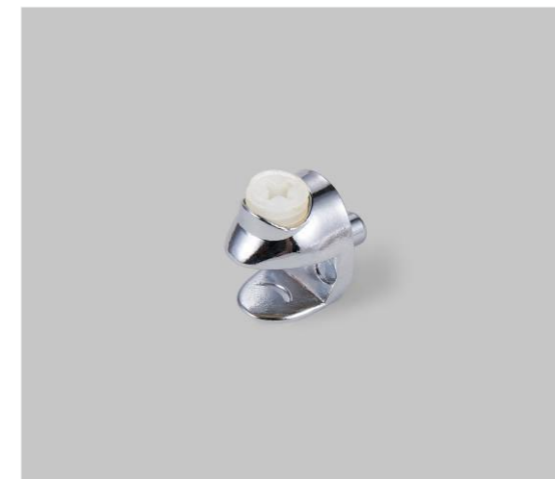

订货号 Item number	MK-WYT-043
产品材质 Material	锌合金 Zinc alloy
表面处理 Finish	亮铬 Bright chrome

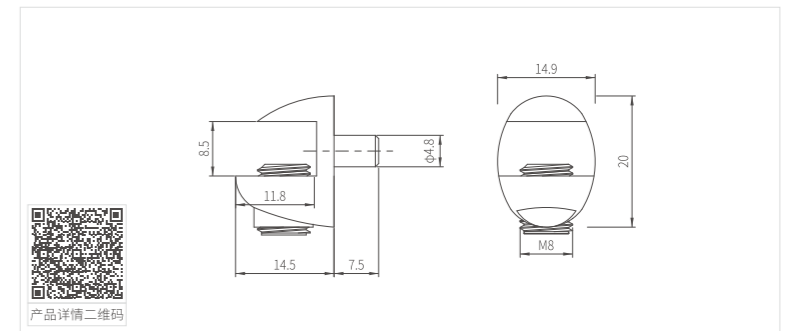

MK-WYT-037 玻璃夹 MK-WYT-037 Glass clip



订货号 Item number	MK-WYT-037
产品材质 Material	锌合金 Zinc alloy
表面处理 Finish	亮铬 Bright chrome

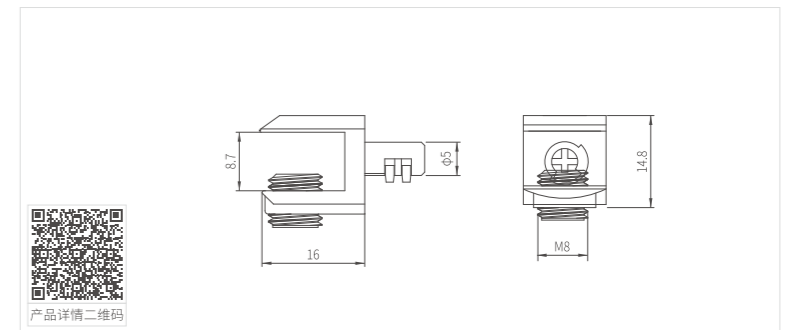

MK-WYT-074 玻璃夹 MK-WYT-074 Glass clip



订货号 Item number	MK-WYT-074
产品材质 Material	锌合金 Zinc alloy
表面处理 Finish	亮铬 Bright chrome

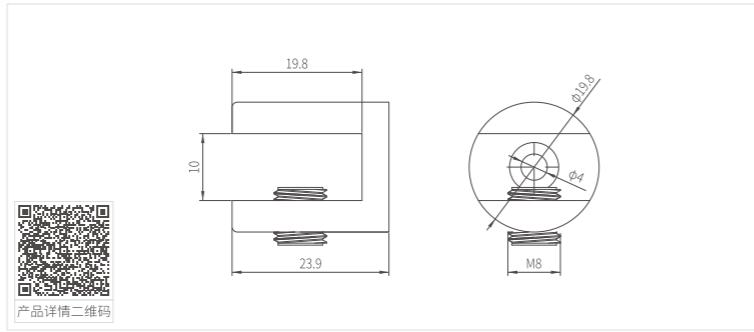

产品详情二维码

MK-WYT-073 玻璃夹 MK-WYT-073 Glass clip



订货号 Item number	MK-WYT-073
产品材质 Material	锌合金 Zinc alloy
表面处理 Finish	亮铬 Bright chrome

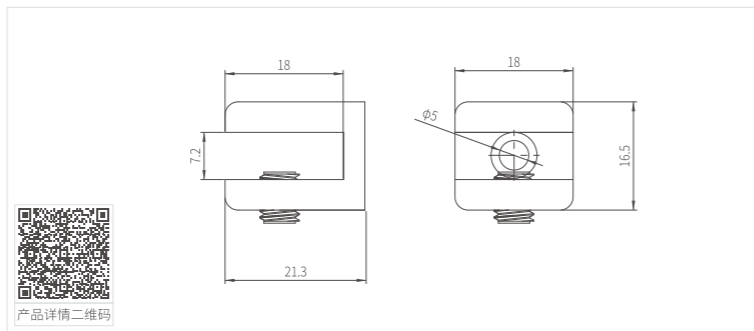

产品详情二维码

MK-WYT-035-1 玻璃夹 MK-WYT-035-1 Glass clip



订货号 Item number	MK-WYT-035-1
产品材质 Material	锌合金 Zinc alloy
表面处理 Finish	亮铬 Bright chrome

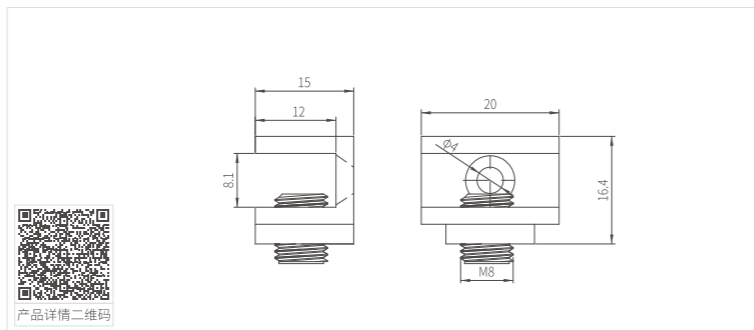

产品详情二维码

MK-WYT-P036 玻璃夹 MK-WYT-P036 Glass clip



订货号 Item number	MK-WYT-P036
产品材质 Material	锌合金 Zinc alloy
表面处理 Finish	亮铬 Bright chrome

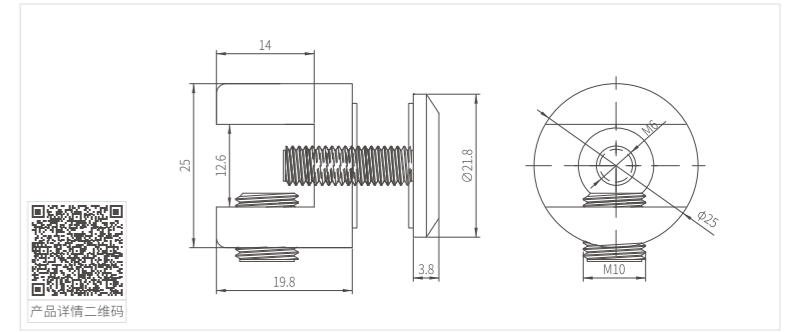

产品详情二维码

MK-WLS-1170A 玻璃夹 MK-WLS-1170A Glass clip



订货号 Item number	MK-WLS-1170A
产品材质 Material	锌合金 Zinc alloy
表面处理 Finish	镍 Nickel plating

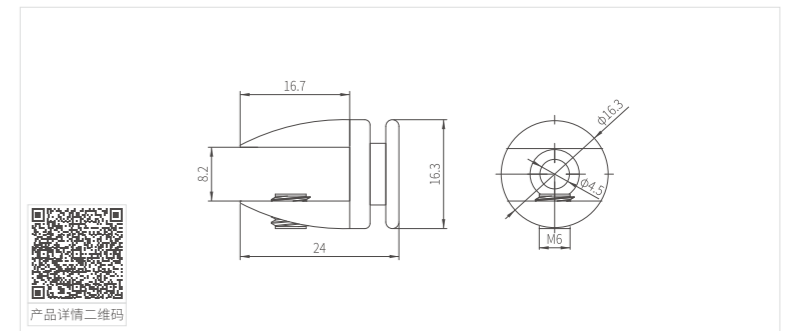

产品详情二维码

MK-WLS-1160A 玻璃夹 MK-WLS-1160A Glass clip

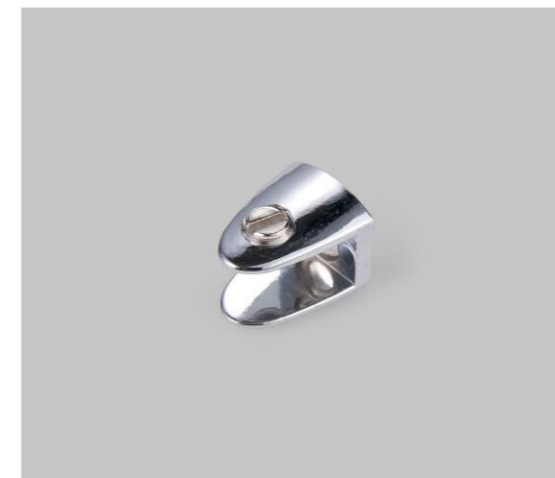

订货号 Item number	MK-WLS-1160A
产品材质 Material	锌合金 Zinc alloy
表面处理 Finish	亮铬 Bright chrome

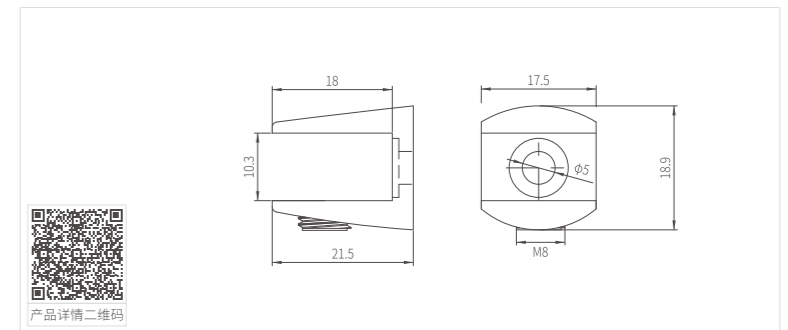

产品详情二维码

MK-WLS-1180A 玻璃夹 MK-WLS-1180A Glass clip



订货号 Item number	MK-WLS-1180A
产品材质 Material	锌合金 Zinc alloy
表面处理 Finish	亮铬 Bright chrome

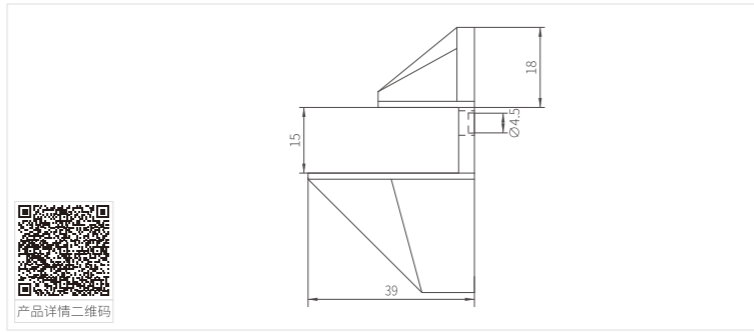

MK-1150A 玻璃夹 MK-1150A Glass clip

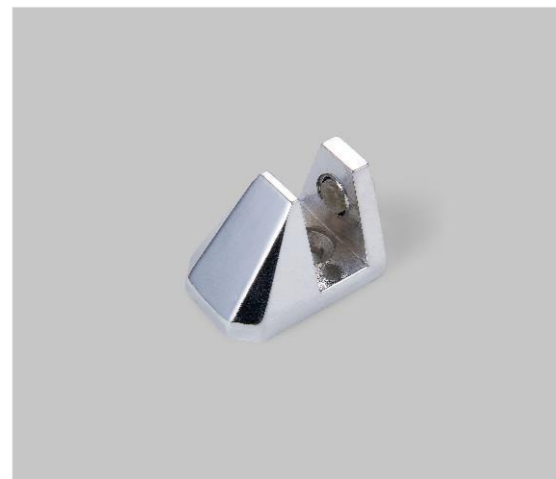

订货号 Item number	MK-1150A
产品材质 Material	锌合金 Zinc alloy
表面处理 Finish	亮铬 Bright chrome

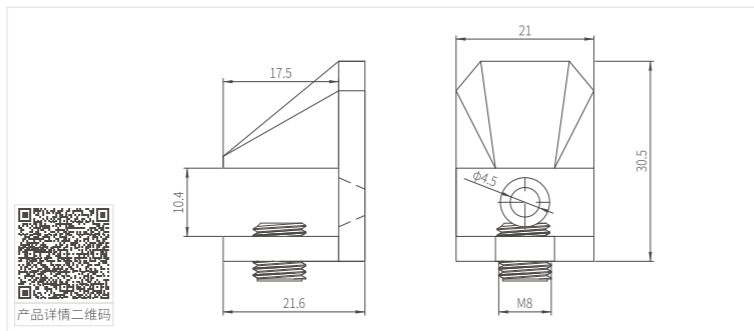

MK-JHD-J101 玻璃夹 MK-JHD-J101 Glass clip



订货号 Item number	MK-JHD-J101
产品材质 Material	锌合金 Zinc alloy
表面处理 Finish	本色 Natural color

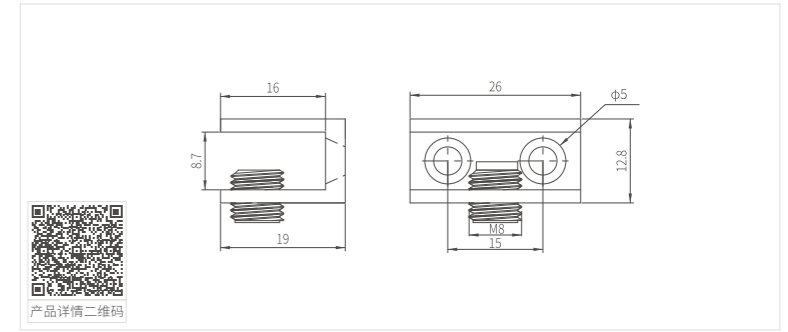

MK-JHD-J63 玻璃夹 MK-JHD-J63 Glass clip

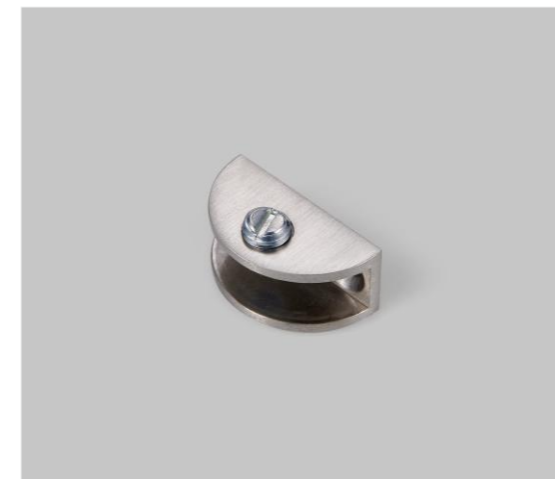

订货号 Item number	MK-JHD-J63
产品材质 Material	锌合金 Zinc alloy
表面处理 Finish	本色 Natural color

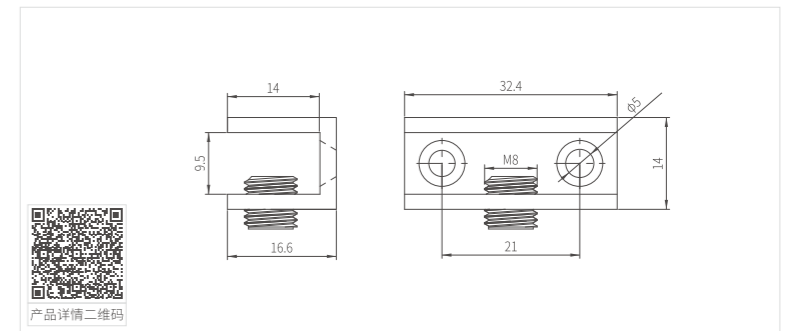

MK-JHD-J82 玻璃夹 MK-JHD-J82 Glass clip



订货号 Item number	MK-JHD-J82
产品材质 Material	锌合金 Zinc alloy
表面处理 Finish	亮铬 Bright chrome

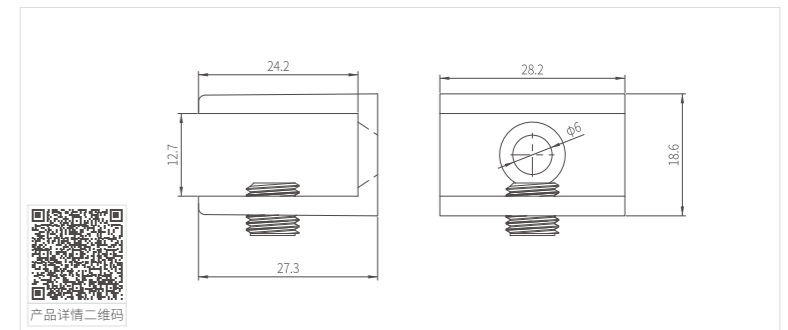



MeiKi明希®

WARDROBE TUBE SUPPORT SERIES
衣管座系列

GRACE IN FORM COMES FROM THE HEART
优雅于形 自由于心

以品质之名
成就不愿被定义的生活姿态
In the name of quality
Achieve an undefined life style

MK-JH-001 衣管座 MK-JH-001 Wardrobe tube support



订货号 Item number	MK-JH-001
产品材质 Material	铝合金+ABS Aluminium alloy+ABS
表面处理 Finish	香槟 Champagne 其他颜色可定制 Other colors can be customized

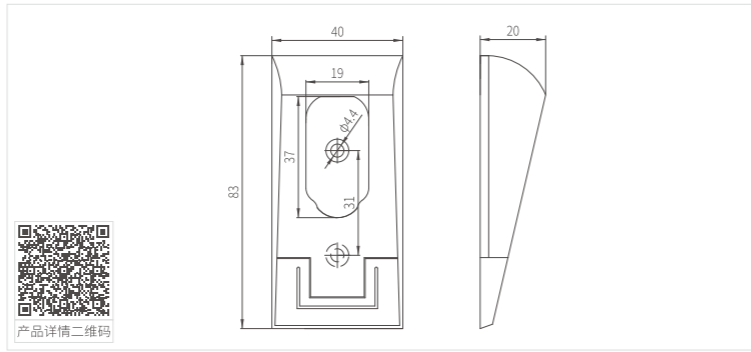

产品详情二维码

MK-JH-003 衣管座 MK-JH-003 Wardrobe tube support



订货号 Item number	MK-JH-003
产品材质 Material	锌合金+ABS Zinc alloy+ABS
表面处理 Finish	珍珠镍 Satin nickel 其他颜色可定制 Other colors can be customized

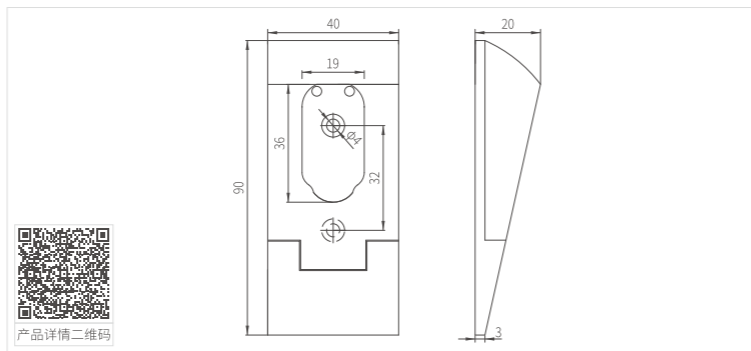

产品详情二维码

MK-JX-TX 桃心衣管座 MK-JX-TX Wardrobe tube support



订货号 Item number	MK-JX-TX
产品材质 Material	锌合金+ABS Zinc alloy+ABS
表面处理 Finish	香槟色 Champagne

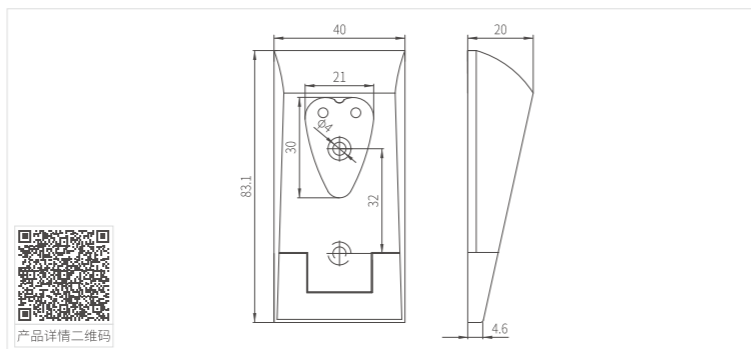

产品详情二维码

MK-JH-007 衣管座 MK-JH-007 Wardrobe tube support



订货号 Item number	MK-JH-007
产品材质 Material	锌合金+ABS Zinc alloy+ABS
表面处理 Finish	黑色 Black 其他颜色可定制 Other colors can be customized

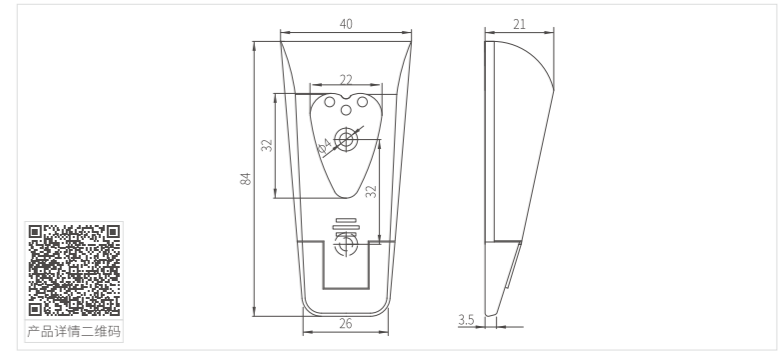

产品详情二维码

MK-JH-010 衣管座 MK-JH-010 Wardrobe tube support



订货号 Item number	MK-JH-010
产品材质 Material	铝合金 Aluminium alloy
表面处理 Finish	灰色 Gray, 金色 Golden

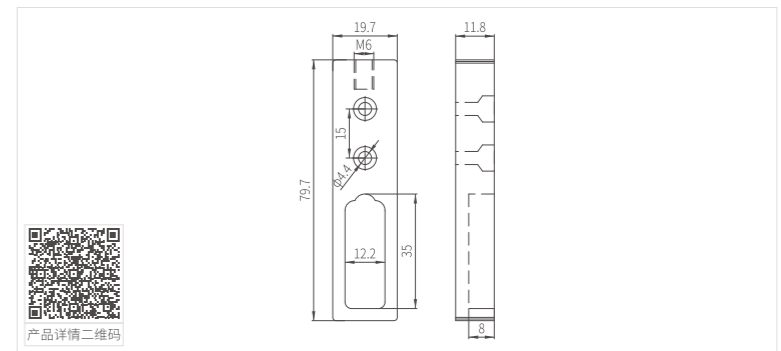

产品详情二维码

MK-JH-014 衣管座 MK-JH-014 Wardrobe tube support



订货号 Item number	MK-JH-014
产品材质 Material	铝合金 Aluminium alloy
表面处理 Finish	金色 Golden, 黑色 Black, 灰色 Gray

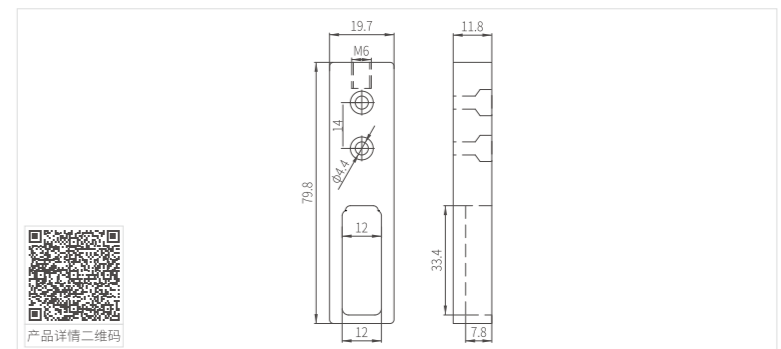

产品详情二维码

MK-JH-016 衣架座 MK-JH-016 Wardrobe tube support



订货号 Item number	MK-JH-016
产品材质 Material	锌合金 Zinc alloy
表面处理 Finish	金色 Golden、黑色 Black、灰色 Gray

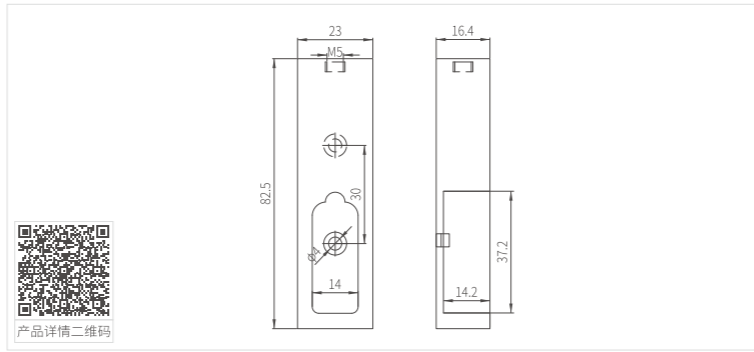

MK-JH-018 衣架座 MK-JH-018 Wardrobe tube support



订货号 Item number	MK-JH-018
产品材质 Material	锌合金 Zinc alloy
表面处理 Finish	咖黑 Coffee black 其他颜色可定制 Other colors can be customized

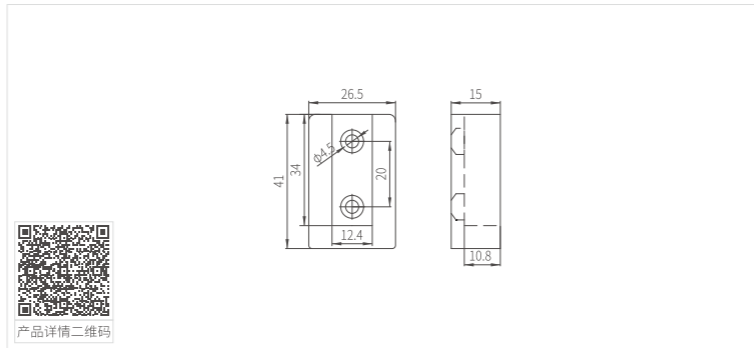

MK-JH-023 衣架座 MK-JH-023 Wardrobe tube support



订货号 Item number	MK-JH-023
产品材质 Material	锌合金 Zinc alloy
表面处理 Finish	金色 Golden、黑色 Black、灰色 Gray

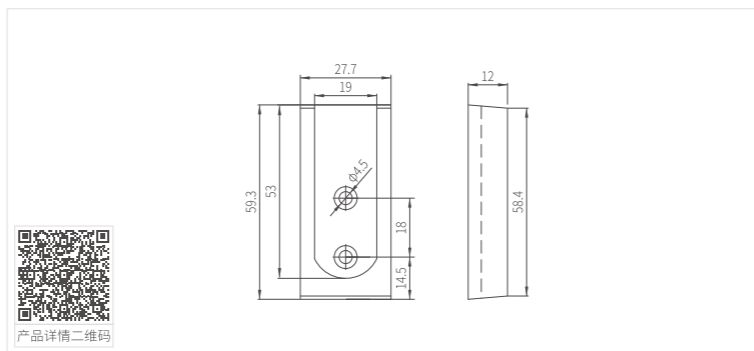

MK-JH-025 衣架座 MK-JH-025 Wardrobe tube support



订货号 Item number	MK-JH-025
产品材质 Material	锌合金 Zinc alloy
表面处理 Finish	灰色 Gray 其他颜色可定制 Other colors can be customized

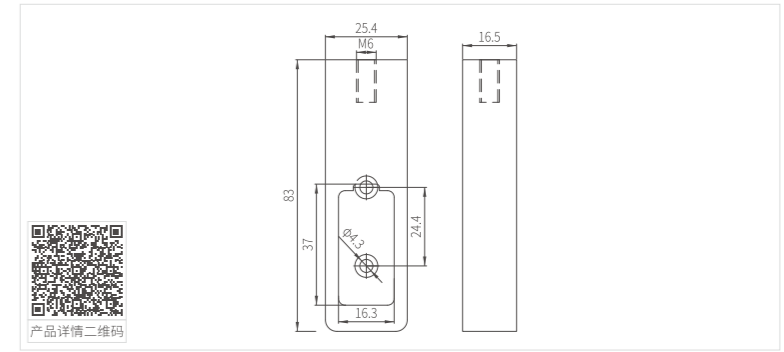

MK-JH-026 衣架座 MK-JH-026 Wardrobe tube support



订货号 Item number	MK-JH-026
产品材质 Material	铝合金 Aluminium alloy
表面处理 Finish	灰色 Grey 其他颜色可定制 Other colors can be customized

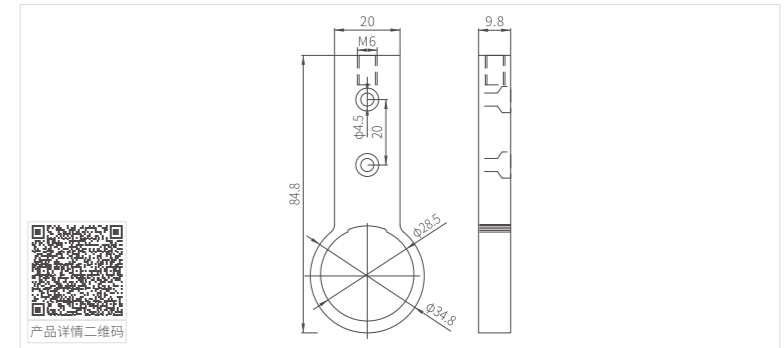

MK-JH-027 衣架座 MK-JH-027 Wardrobe tube support



订货号 Item number	MK-JH-027
产品材质 Material	铝合金+ABS Aluminium alloy+ABS
表面处理 Finish	黑色 Black 其他颜色可定制 Other colors can be customized

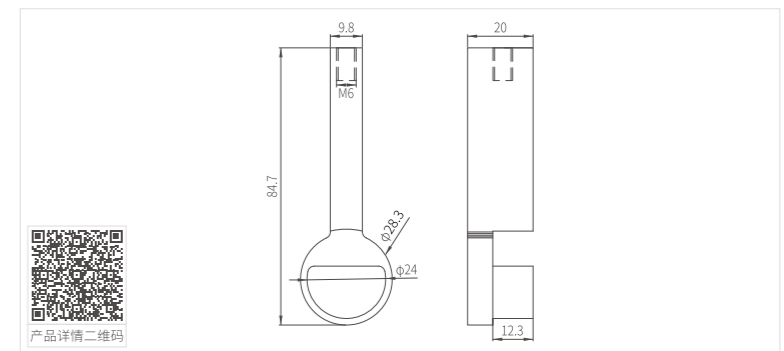

MK-JH-030 衣管座 MK-JH-030 Wardrobe tube support



订货号 Item number	MK-JH-030
产品材质 Material	铝合金 Aluminium alloy
表面处理 Finish	金色 Golden、黑色 Black

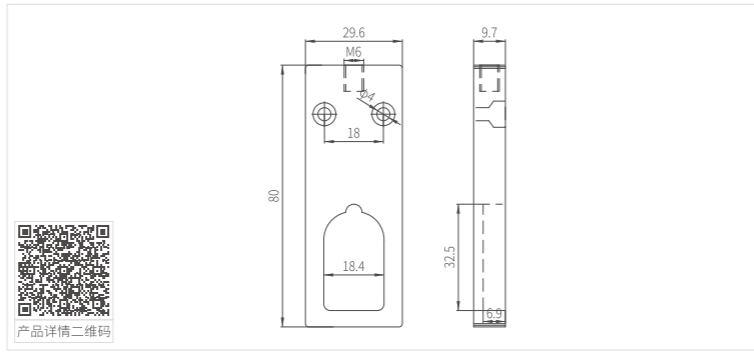

产品详情二维码

MK-JH-044 衣管座 MK-JH-044 Wardrobe tube support



订货号 Item number	MK-JH-044
产品材质 Material	锌合金 Zinc alloy
表面处理 Finish	金色 Golden、黑色 Black、灰色 Gray

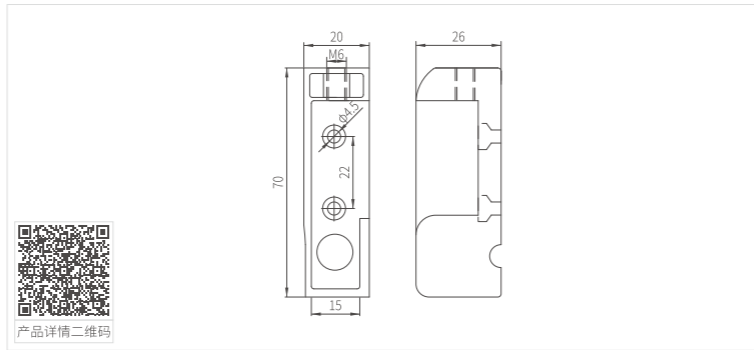

产品详情二维码

MK-YFS-QS 全塑衣管座 MK-YFS-QS Plastic clothes tube Wardrobe tube support



订货号 Item number	MK-YFS-QS
产品材质 Material	ABS
表面处理 Finish	香槟色 Champagne

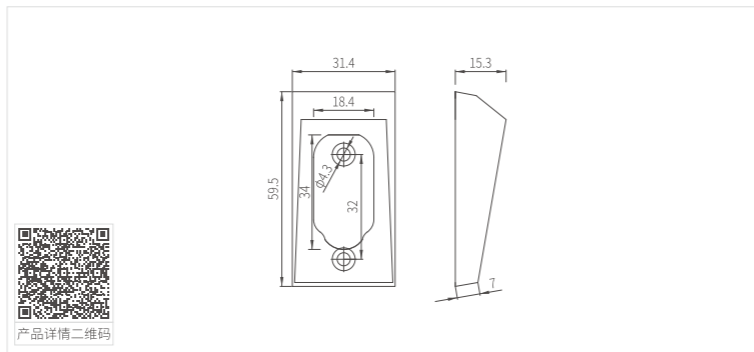

产品详情二维码

MK-JX-OVAL 椭圆衣管座 MK-JX-OVAL Wardrobe tube support

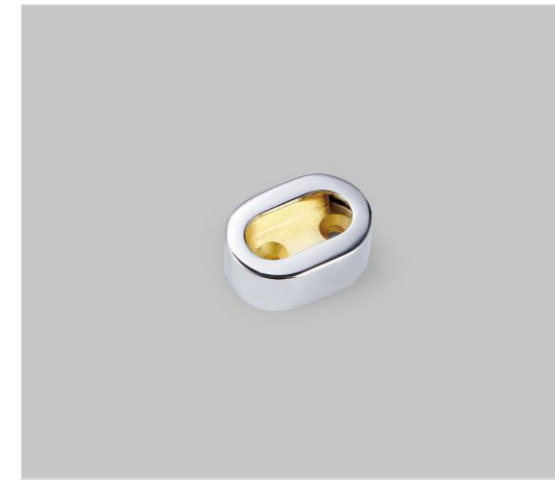

订货号 Item number	MK-JX-OVAL
产品材质 Material	锌合金 Zinc alloy
表面处理 Finish	亮铬 Bright chrome

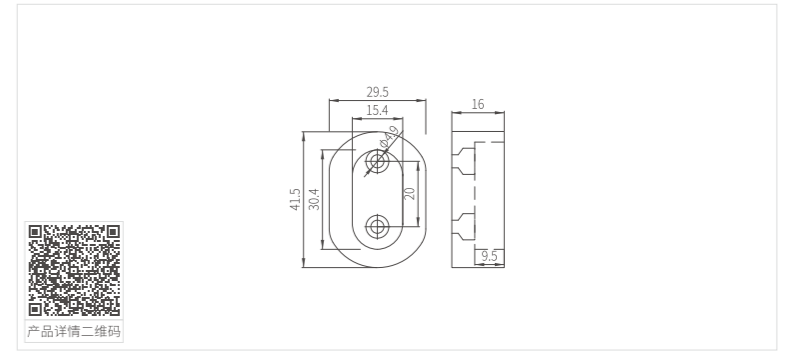

产品详情二维码





MeiKi明希®

PUSH OPEN SYSTEM SERIES
反弹器系列

SIMPLE, FLEXIBLE AND FULL OF ELASTICITY
简约灵动 弹力十足

按压反弹, 柜体免拉手
简约时尚, 凝聚生活的艺术
Press rebound, cabinet handle free
Simple fashion, condensing the art of life

MK-QF-2313 带卡反弹器 MK-QF-2313 Palletized push open system



订货号 Item number	MK-QF-2313
产品材质 Material	塑料 Plastic
产品颜色 Finish	灰色 Gray
按压力 Pressing force	40N

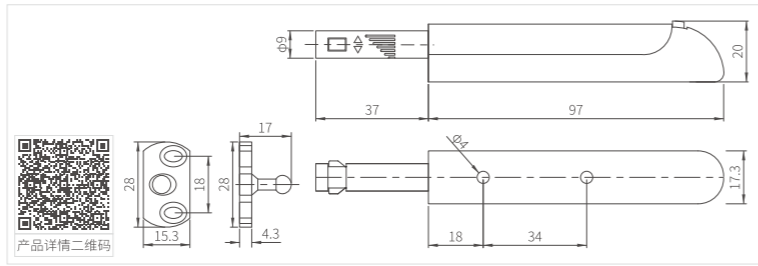

产品详情二维码

MK-QF-2315 带卡反弹器 MK-QF-2315 Palletized push open system



订货号 Item number	MK-QF-2315
产品材质 Material	塑料 Plastic
产品颜色 Finish	灰色 Gray
按压力 Pressing force	40N

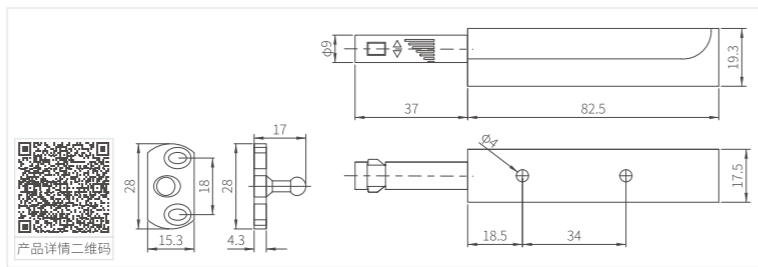

产品详情二维码

MK-QF-862A 带磁反弹器 MK-QF-862A Magnetic push open system



订货号 Item number	MK-QF-862A
产品材质 Material	塑料 Plastic
产品颜色 Finish	灰色 Gray
按压力 Pressing force	22N

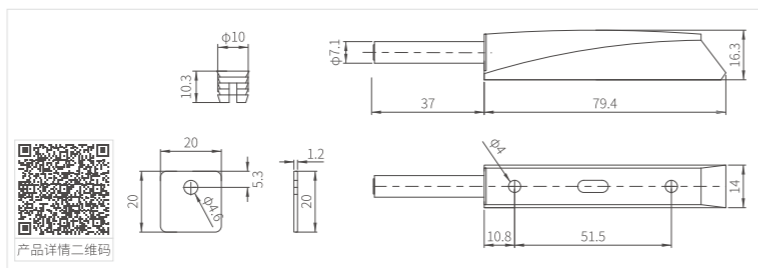

产品详情二维码

MK-QF-883 带磁反弹器 MK-QF-883 Magnetic push open system



订货号 Item number	MK-QF-883
产品材质 Material	塑料 Plastic
产品颜色 Finish	灰色 Gray
按压力 Pressing force	50N

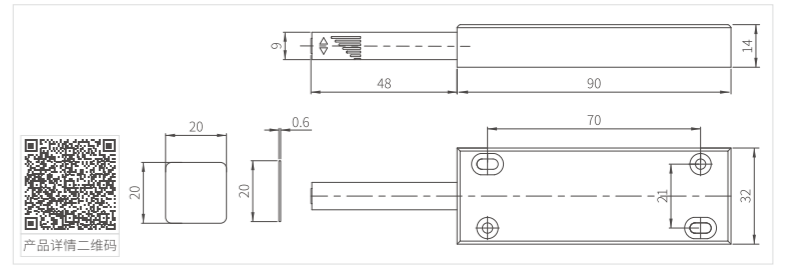

产品详情二维码

MK-37mm 带胶反弹器 MK-37mm Glue push open system



订货号 Item number	MK-37mm
产品材质 Material	塑料 Plastic
产品颜色 Finish	灰色 Gray

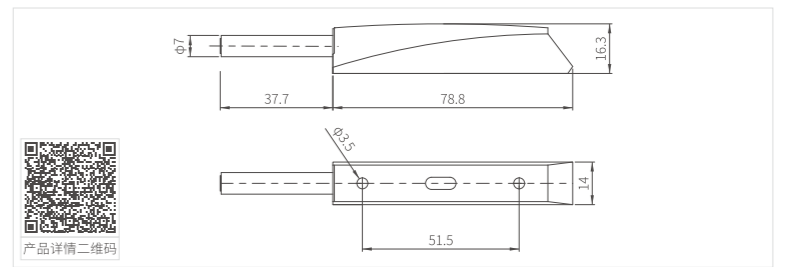

产品详情二维码

MK-20mm 带磁反弹器 MK-20mm Magnetic push open system



订货号 Item number	MK-20mm
产品材质 Material	塑料 Plastic
产品颜色 Finish	灰色 Gray

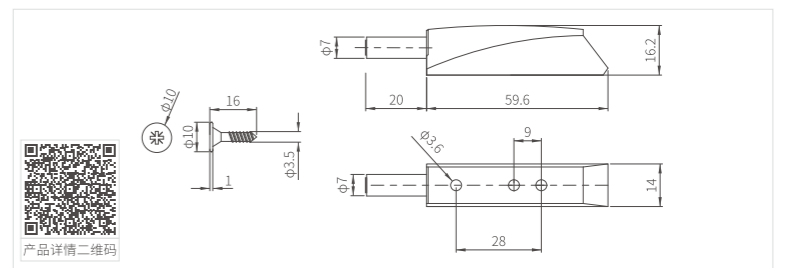

产品详情二维码

MK-QF-2328 反弹器 MK-QF-2328 Push open system



订货号 Item number	MK-QF-2328
产品材质 Material	塑料 Plastic
产品颜色 Finish	灰色 Grey

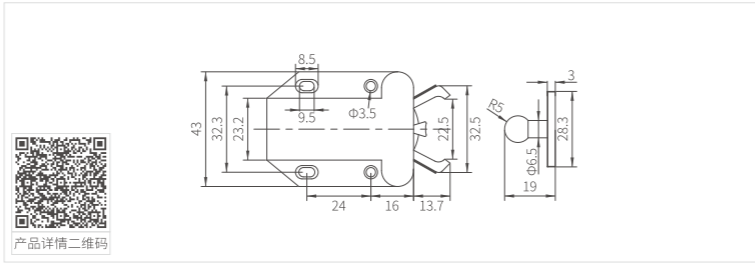

MK-QF-2328 反弹器 MK-QF-2328 Push open system



订货号 Item number	MK-QF-2328
产品材质 Material	塑料 Plastic
产品颜色 Finish	黑色 Black

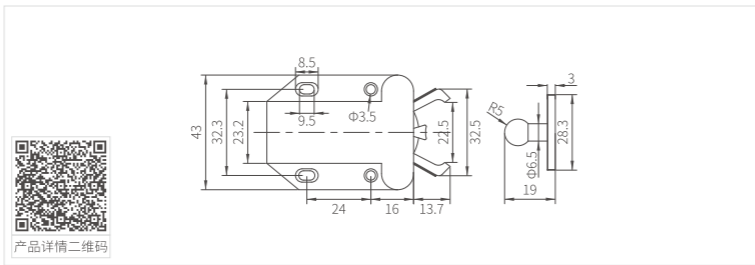

MK-QF-804 反弹器 MK-QF-804 Push open system



订货号 Item number	MK-QF-804
产品材质 Material	塑料 Plastic
产品颜色 Finish	黑色 Black

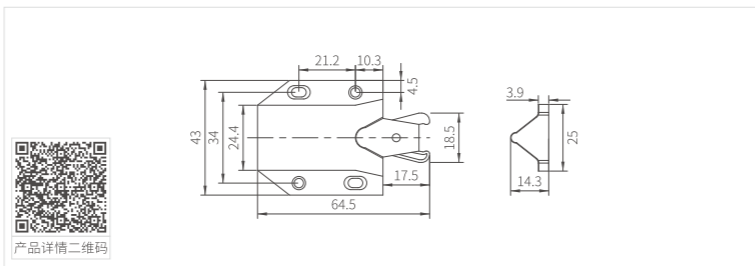



MeiKi明希®

CABINET HANGER SERIES
挂码系列

THE POWER OF A THOUSAND POUNDS IS
NOTHING TO FEAR
千钧之力 无所畏惧

承重力强悍, 各种柜体适用
满足定制家居的个性化需求

Strong bearing capacity, suitable for all kinds of cabinets
Meet the individual needs of customized home

MK-WH-01 隐藏式橱柜挂码(分左右) MK-WH-01 Invisible cabinet hanger-01

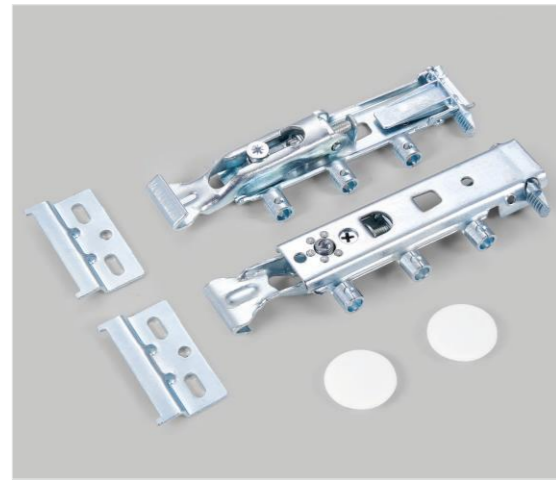

订货号 Item number	MK-WH-01
产品材质 Material	冷轧钢 Cold rolled steel
表面处理 Finish	镀锌 Zinc plating
产品承重 Loading capacity	130KG/对 pair
上下调节 Up and down adjustment	18mm

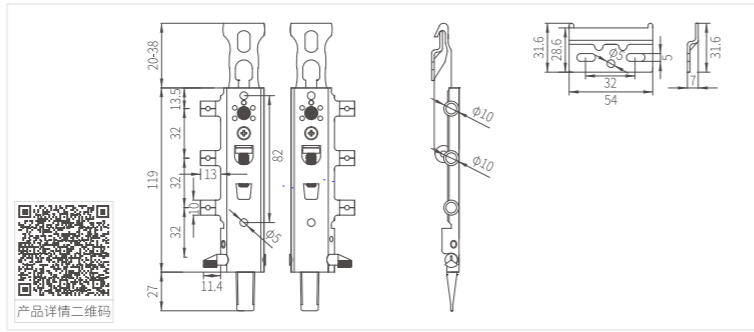

MK-WH-02 隐藏式橱柜挂码(不分左右) MK-WH-02 Invisible cabinet hanger-02

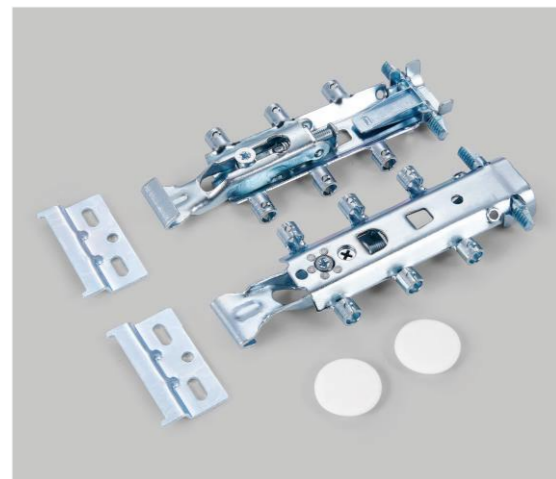

订货号 Item number	MK-WH-02
产品材质 Material	冷轧钢 Cold rolled steel
表面处理 Finish	镀锌 Zinc plating
产品承重 Loading capacity	130KG/对 pair
上下调节 Up and down adjustment	18mm

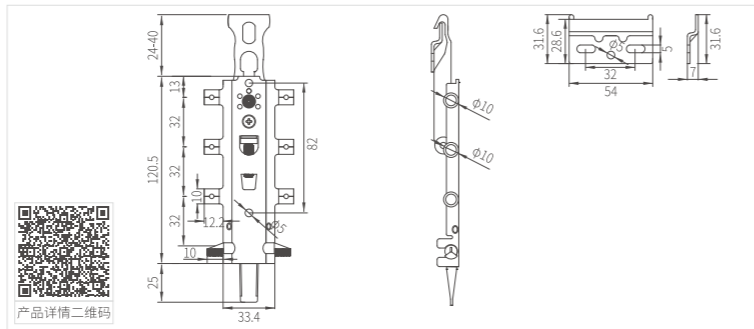

MK-YFS-003 橱柜挂码 MK-YFS-003 YFS cabinet hanger-03



订货号 Item number	MK-YFS-003
产品材质 Material	冷轧钢+ABS Cold rolled steel+ABS
表面处理 Finish	镀锌 Zinc plating, 白色 White
产品承重 Loading capacity	60KG/对 pair

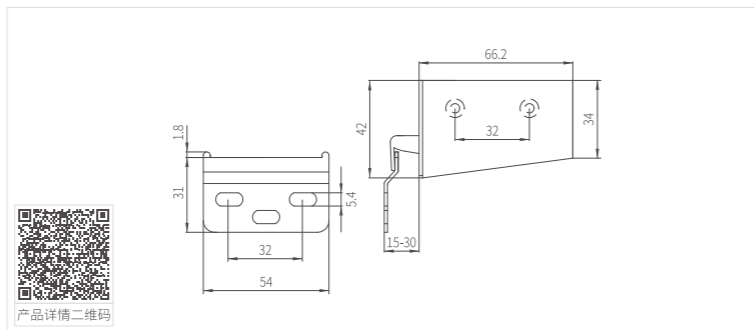

MK-GM-ATC301.12.55 轻型隐形吊码 MK-GM-ATC301.12.55 Light Type Invisible Hanger



订货号 Item number	MK-GM-ATC301.12.55
产品材质 Material	碳钢+塑料 Carbon steel + Plastic
表面处理 Finish	蓝白锌 Blue zinc
适用板厚 Thickness of applicable plate	≤18mm
最大承重 Maximum bearing capacity	800N

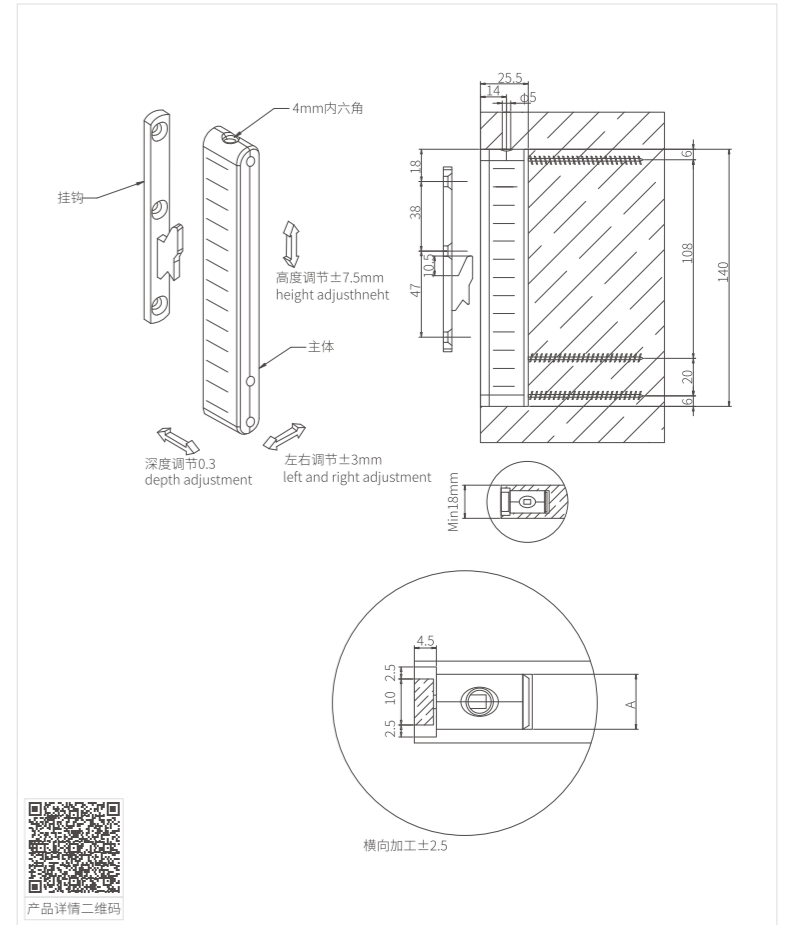



MeiKi明希®

GAS SUPPORT SERIES
支撑系列

FLEXIBLE AND GENTLE OPENING AND CLOSING
伸缩自如 轻柔开合

支撑力强, 灵活开启
凝结品质生活的畅想

Strong support, flexible opening
Condense the imagination of quality life

MK-KY-JJSF-300 极简上翻支撑 MK-KY-JJSF-300 Upward free stop lift system



订货号 Item number	MK-KY-JJSF-300
产品材质 Material	金属 Metal
表面处理 Finish	镍 Nickel plating, 镀铬 Chrome plating
承重类型 Capacity range	轻型 Light type: 4-8Kg, 重型 Heavy type: 8-12Kg
门板宽度 Door panel width	450-1200mm
门板高度 Door panel height	350-650mm

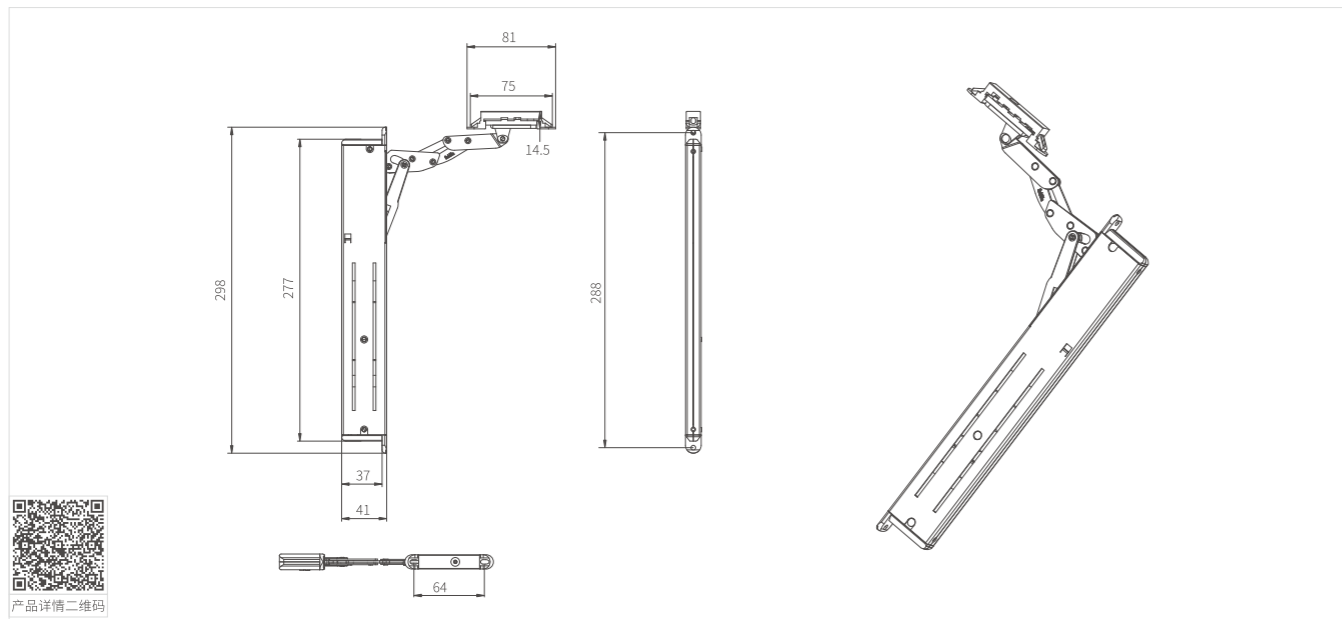

产品详情二维码

极简上翻开孔参数 Upward free stop lift system perforation parameters

1. 调节 adjustment

力的无级调节 Force adjustment area

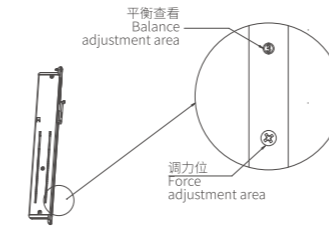

方向调节 Direction adjustment area

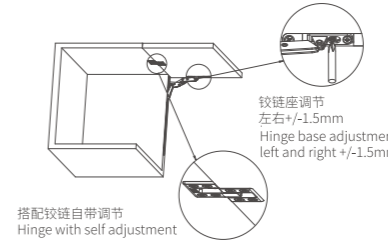

2. 型材推荐截面 profile recommended section

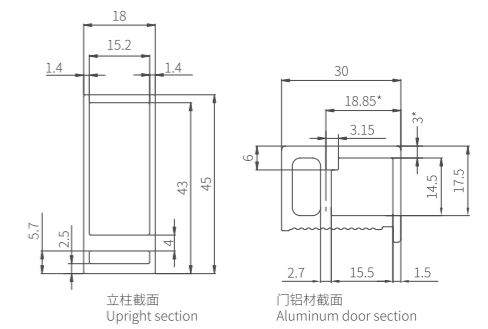

3. 开孔参数 perforation parameters

(图示为单边开孔示意图, 另一边与之对称) The picture is a schematic diagram of one side, and other side is symmetry with it

木柜体嵌入式安装
Wooden cabinet flush mounted

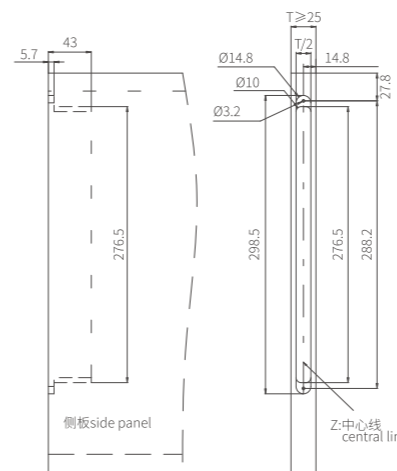

木柜体侧面安装
Wooden cabinet side installation

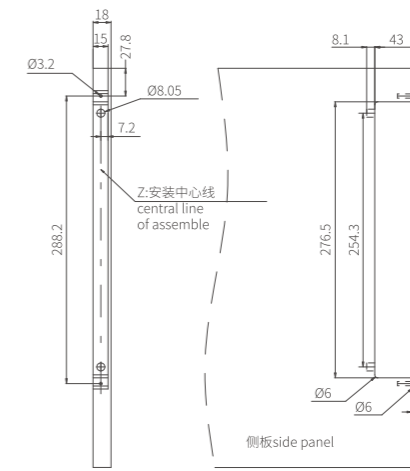

带立柱安装
Installation with column

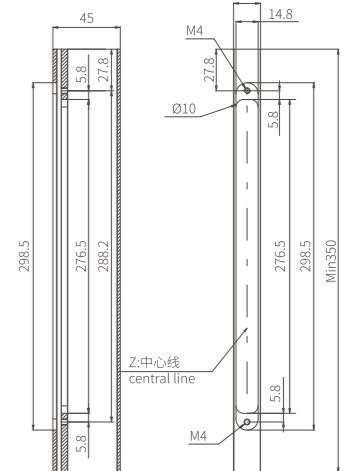

木门开孔
Wooden door perforation

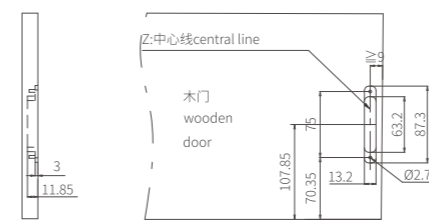

Z: 与柜体开孔中心线一致
consistent with the cabinet center line perforation

铝门型材开孔
Aluminum door

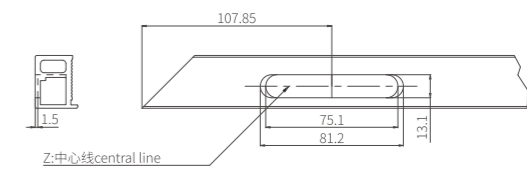

Z: 与柜体开孔中心线一致
consistent with the cabinet center line perforation

MK-HL-G123 上翻随意停支撑 MK-HL-G123 Upward free stop lift system



订货号 Item number	MK-HL-G123
产品材质 Material	铁+塑料 Iron+Plastic
表面处理 Finish	镍 Nickel plating
适用范围 Available	橱柜的上翻木门和铝框门 Up-turning wooden door and aluminum-frame door

产品特性 Features	
上翻支撑适用于柜体高度较低的吊柜和高柜	The lift system is suitable for wall cabinets and tall cabinets with low height
关门角度25°以下具有缓冲功能、最大开启角度110°	With soft closing under angle 25° max opening angle is 110°
柜体无需安装铰链	No need hinges for cabinet
开启轻松,任意角度悬停	Easy to open, free stop function
开启、悬停、闭合力度可调节	Force of opening or closing is adjustable
免工具安装,安装拆卸方便快捷	Easy assembly and adjustment
装饰盖多色可选	Different color options for decoration cover

使用建议 Usage Suggestion

产品 Model	柜门高度 Cabinet Height (mm)
MK-HL-G123-L-1200-1800	330-450
MK-HL-G123-M-1700-2250	360-500
MK-HL-G123-H-2100-3100	400-500
MK-HL-G123-HD-2500-4000	400-500



门板高度: 330-500 mm Cabinet Height: 330-500 mm
 门板宽度: 600-1200 mm Cabinet Width: 600-1200 mm
 门板厚度: 16, 18, 22, 26, 28mm Front Thickness: 16, 18, 22, 26, 28mm

产品详情二维码

MK-HL-G125 上翻折叠门支撑 MK-HL-G125 Upward folding door lift system



订货号 Item number	MK-HL-G125
产品材质 Material	锌合金+塑料+铁 Zinc alloy+Plastic+Iron
表面处理 Finish	镍 Nickel plating, 镀铬 Chrome plating
承重类型 Capacity range	多种可选 Different options
柜高要求 Cabinet height	600-1000mm
柜宽要求 Cabinet width	1200mm以内的柜体 ≤1200mm

产品特性 Features	
打开时,上翻折叠门的两块面板在中间折合。	When opened, the two panels of the upward-folding door fold in the center.
上翻折叠门支撑适用于配两块较大面板的高吊柜,可确保拉手在任何位置均能轻松触及,也可应用于不同高度的面板。	The upward folding door support is suitable for high ceiling cabinets with two large hinged panels and ensures that the handles can be easily reached in any position and can also be used for panels of different heights.
关闭轻柔,皆因产品带阻尼	Gently closing thanks to damping
轻松开启,无极悬停,方便拿取柜内物品	Easy to open, infinitely variable rest stops for easy access to contents
应用范围广,安装简单,调节方便	Wide range of applications, easy to install, easy to adjust
稳定性强,宽面板亦然,使用寿命长	Stability, even with wide fronts. Excellent durability
可自由选择拉手的安装位置	Door handle can be installed in ideal position
无突出的部件	No protruding parts

使用建议 Usage Suggestion

产品型号 Model	柜体门高 Cabinet Height	柜体宽度 Cabinet width	铝杆长度 Alu.bar Length	连接铰链 Hinge	适配门板重量 Fronts Weight	适配数量 Product Qty
MK-HL-G125-A	550-650mm	600-700mm	200mm	2 PCS	4.1-5.0kg	1 set
MK-HL-G125-B	550-650mm	600-850mm	200mm	2 PCS	5.1-6.0kg	1 set
MK-HL-G125-C	700-850mm	600-850mm	300mm	2 PCS	6.1-7.0kg	1 set
MK-HL-G125-D	700-850mm	600-850mm	300mm	2 PCS	7.1-8.0kg	1 set
MK-HL-G125-E	700-850mm	600-850mm	300mm	2 PCS	8.1-9.0kg	1 set
MK-HL-G125-F	900-950mm	900-1000mm	350mm	3 PCS	9.1-10.0kg	1 set

注意: 可根据柜门的尺寸和重量,定制相匹配的产品 Note: Can make customized products to match with the cabinet size and front weight

门高600mm,使用200mm的铝杆 Total door height 600mm, alu. bar uses 200mm.
 门高650-850mm,使用300mm的铝杆 Total door height 650-850mm, alu. bar uses 300mm.
 门高900mm,使用350mm的铝杆 Total door height more than 900mm alu. bar uses 350mm.
 如果门板宽度大于900mm或者门板重量大于9kg,使用3个连接铰链 If door width more than 900mm or panel weight more than 9kg, use 3 hinges



产品详情二维码

MK-HL-G317 上翻随意停支撑 MK-HL-G317 Upward free stop lift system



订货号 Item number	MK-HL-G317
产品材质 Material	铁+塑料 Iron+Plastic
表面处理 Finish	镍 Nickel plating, 镀铬 Chrome plating, 黑镍 Black

产品特性 Features	
柜门开启30°以上, 任意角度悬停	Free stop at any position in opening angle about 30°
如配合缓冲铰链使用, 关门具有缓冲阻尼	Door can soft close if used with soft hinges
通过旋转调节开关, 即可调节承重力的大小	Load-bearing capacity can be adjusted by turning the inside screw

使用建议 Usage Suggestion

产品型号 Model	柜体高度 Cabinet Height (mm)	适配数量 Product QTY	开启角度 Open Angle
MK-HL-G317-L-600-1200	300-400mm	1 PCS	100°
MK-HL-G317-M-1050-2025	300-450mm	1 PCS	100°
MK-HL-G317-H-1900-3300	380-550mm	1 PCS	100°

柜体高度:300-550mm Cabinet height:300-550mm
 面板宽度:500-1500mm Front width:500-1500mm
 柜体净深至少200mm Cabinet depth should be 200mm at least
 若铰链的开启角度比较小, 那么柜门的开启角度受铰链限制 The open angle of the door will be limited by the angle of used hinges



产品详情二维码

MK-HL-G127 上翻随意停支撑 MK-HL-G127 Upward free stop lift system

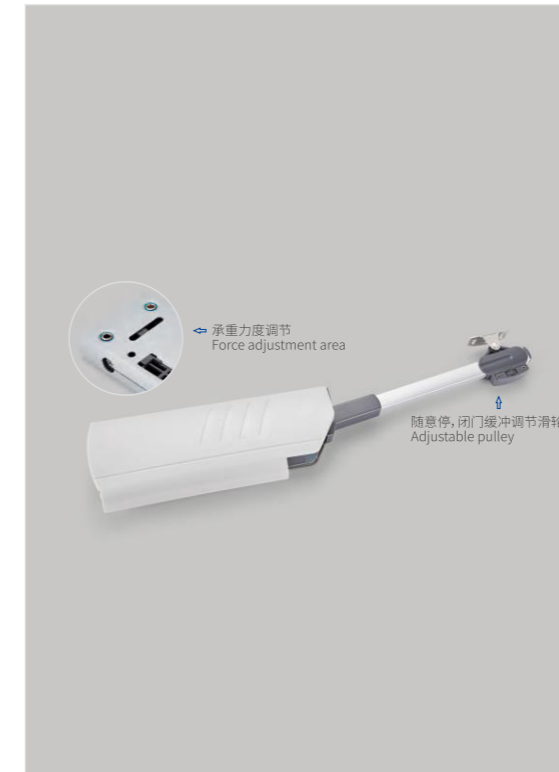

订货号 Item number	MK-HL-G127
产品材质 Material	铁+铝+塑料 Iron+ Alu+ Plastic
表面处理 Finish	氧化 Oxidation
承重 Capacity	轻型:3-4.5kg/pc Light type: 3-4.5 kg/pc、 重型:5-6.5kg/pc Heavy type: 5-6.5kg/pc
柜体高度 Cabinet Height	300-500mm
柜体宽度 Cabinet Width	1200mm以内 ≤1200mm
柜体深度 Cabinet Depth	>250mm
门板厚度 Thickness	16、18、22、26、28mm
适用范围 Available	橱柜的上翻木门和铝框门 Up-turning wooden door and aluminum-frame door

产品特性 Features	
支撑内部带有阻尼器, 柜门打开30°以上, 任意角度悬停; 小于30°, 阻尼自动缓慢关闭。	With interior damper, product with free stop function when opening angle more than 30° and has soft closing function when closing angle under 30.
开启轻松	Easy to open
开启、悬停、闭合力度可调节	Force is adjustable
免工具安装, 安装拆卸方便快捷	Easy assembly and adjustment
结构紧凑, 空间利用率更高	Compact structure, higher space utilization



产品详情二维码

MK-HL-G327 上翻随意停支撑 MK-HL-G327 Upward free stop lift system



订货号 Item number	MK-HL-G327
产品材质 Material	铁+ 塑料 Iron+Plastic
表面处理 Finish	镍 Nickel plating, 玛黑 Black
适用范围 Available	橱柜的上翻木门和铝框门 Up-turning wooden door and aluminum-frame door

产品特性 Features	
柜门开启30°以上, 任意角度悬停	Free stop at any position in opening angle about 30°
如配合缓冲铰链使用, 关门具有缓冲阻尼	Door can soft close if used with soft hinges
通过旋转调节开关, 即可调节承重力的大小	Force can be adjusted by turning the inside screw

使用建议 Usage Suggestion

产品型号 Model	柜体高度 Cabinet Height (mm)	适配数量 Product QTY	开启角度 Open Angle
MK-HL-G327-L-520-920	240-400mm	1 PCS	100°
MK-HL-G327-M-1200-1750	300-400mm	1 PCS	100°
MK-HL-G327-H-1500-2240	400-500mm	1 PCS	100°

柜体高度:240-500mm Cabinet height: 240-500mm
 面板宽度:500-1500mm Front width: 500-1500mm
 柜体净深至少200mm Cabinet depth should be 200mm at least
 若铰链的开启角度比较小, 那么柜门的开启角度受铰链限制 The open angle of the door will be limited by the angle of used hinges



产品详情二维码

MK-KR-A008 带缓冲阻尼胶头支撑 MK-KR-A008 Soft close damping gas support



订货号 Item number	MK-KR-A008
产品材质 Material	塑料 Plastic、铁 Iron、铜 Copper、钢 Steel
管表面处理 Finish	镀铬 Chrome plating、喷漆 spray paint
中心距 Central distance	245mm
行程 Stroke	90mm
举力规格 Lift specification	20-350N
产品用途 Product use	气动上翻支撑 Pneumatic upturn support
用途说明 Advantage	可使合适重量的上翻木门、铝框门稳定速度慢慢向上翻起。 Can be used to makewood door, aluminum openslowly upward.

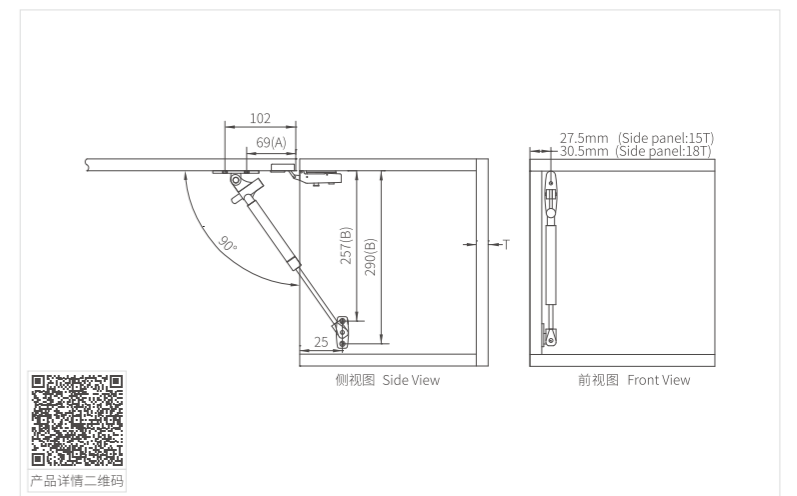

产品详情二维码

MK-KR-A004 盖仔头胶芯上翻支撑 MK-KR-A004 Lift up gas support with two plastic fixators



订货号 Item number	MK-KR-A004
产品材质 Material	塑料 Plastic、铁 Iron、铜 Copper、钢 Steel
管表面处理 Finish	镀铬 Chrome plating、喷漆 Spray paint
中心距 Central distance	245mm
行程 Stroke	90mm
举力规格 Lift specification	20-350N
产品用途 Product use	气动上翻支撑 Pneumatic upturn support
用途说明 Advantage	可使合适重量的上翻木门、铝框门稳定速度慢慢向上翻起。 Can be used to makewood door、aluminum open slowly upward.

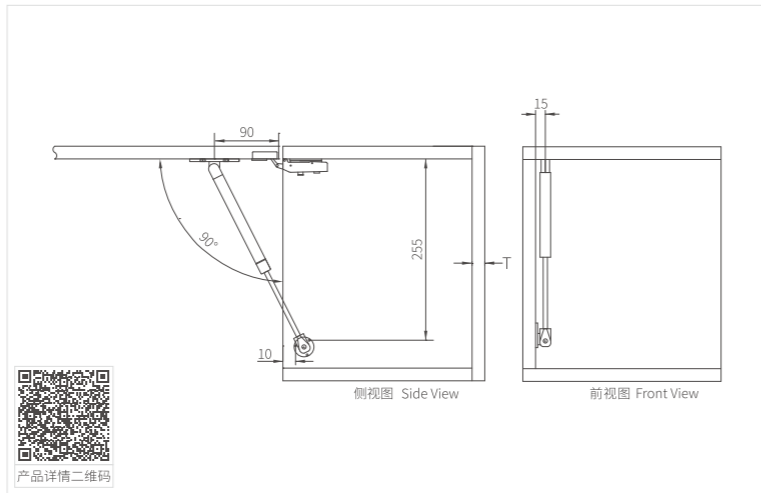

MK-KR-A001 上翻气动支撑 MK-KR-A001 Lift up gas support



订货号 Item number	MK-KR-A001
产品材质 Material	塑料 Plastic、铁 Iron、铜 Copper、钢 Steel
管表面处理 Finish	镀铬 Chrome plating、喷漆 Spray paint
中心距 Central distance	245mm
行程 Stroke	90mm
举力规格 Lift specification	20-350N
产品用途 Product use	气动上翻支撑 Pneumatic upturn support
用途说明 Advantage	可使合适重量的上翻木门、铝框门稳定速度慢慢向上翻起。 Can be used to makewood door、aluminum openslowly upward.

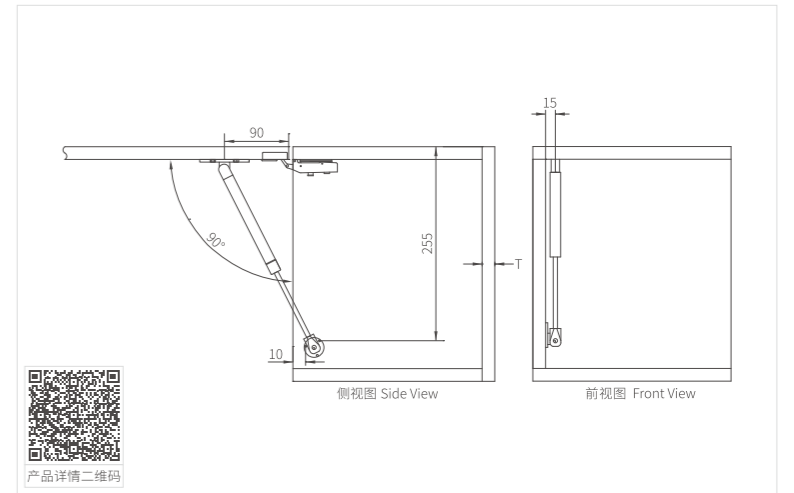

MK-KR-B004 铝框上翻支撑 MK-KR-B004 Aluminum-frame lift up gas support



订货号 Item number	MK-KR-B004
产品材质 Material	塑料 Plastic、铁 Iron、铜 Copper、钢 Steel
管表面处理 Finish	镀铬 Chrome plating、喷漆 spray paint
中心距 Central distance	245mm
行程 Stroke	90mm
举力规格 Lift specification	20-350N
产品用途 Product use	气动上翻支撑 Pneumatic upturn support
用途说明 Advantage	可使合适重量的上翻木门、铝框门稳定速度慢慢向上翻起。 Can be used to makewood door、aluminum open slowly upward.

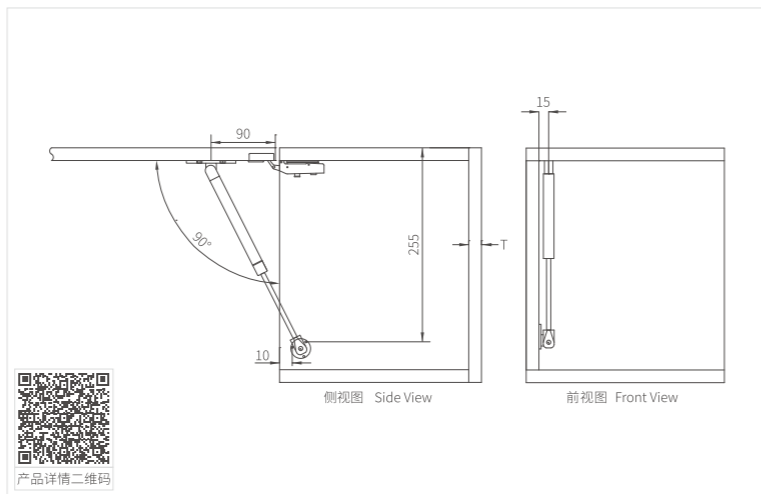

MK-KR-A002 上翻气动支撑 MK-KR-A002 Lift up gas support



订货号 Item number	MK-KR-A002
产品材质 Material	塑料 Plastic、铁 Iron、铜 Copper、钢 Steel
管表面处理 Finish	镀铬 Chrome plating、喷漆 spray paint
中心距 Central distance	245mm
行程 Stroke	90mm
举力规格 Lift specification	20-350N
产品用途 Product use	气动上翻支撑 Pneumatic upturn support
用途说明 Advantage	可使合适重量的上翻木门、铝框门稳定速度慢慢向上翻起。 Can be used to makewood door、aluminum openslowly upward.

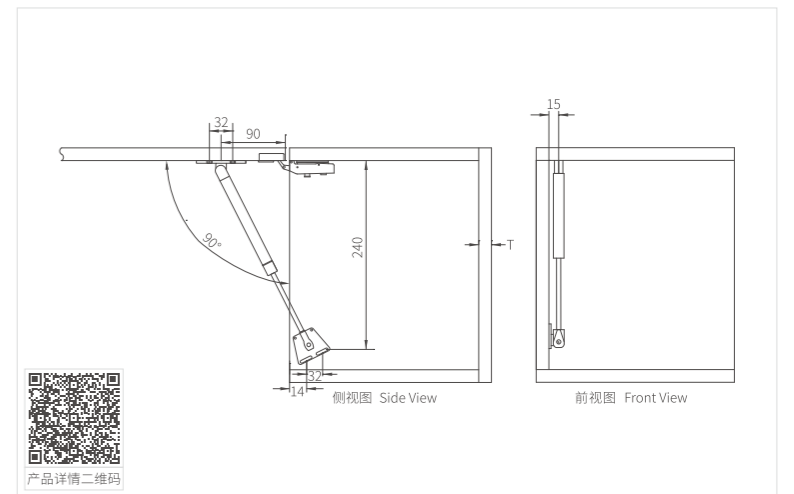

MK-WLS-3203 随意停支撑 MK-WLS-3203 Gas support



订货号 Item number	MK-WLS-3203
产品材质 Material	锌合金+铁+塑料 Zinc+iron+plastic
颜色可选 Finish	镍 Nickel plating

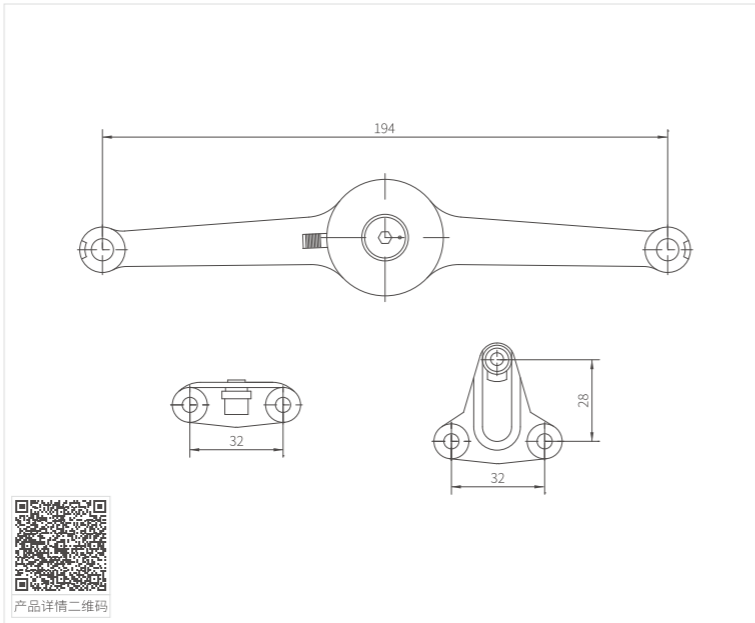

MK-WLS-3202C 随意停支撑 MK-WLS-3202C Gas support



订货号 Item number	MK-WLS-3202C
产品材质 Material	锌合金+铁+塑料 Zinc+iron+plastic
颜色可选 Finish	镍 Nickel plating

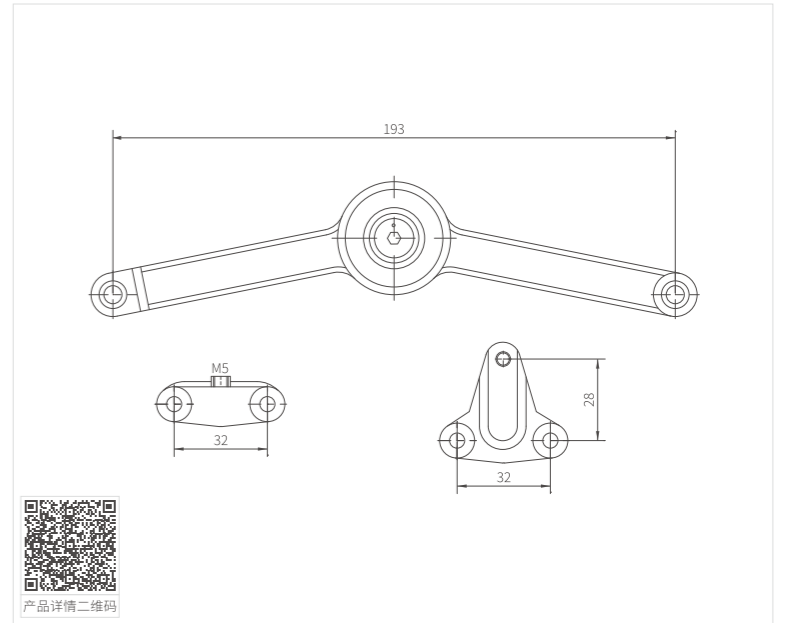

MK-WLS-3202A 随意停支撑 MK-WLS-3202A Gas support



订货号 Item number	MK-WLS-3202A
产品材质 Material	锌合金+铁+塑料 Zinc+iron+plastic
颜色可选 Finish	镍 Nickel plating

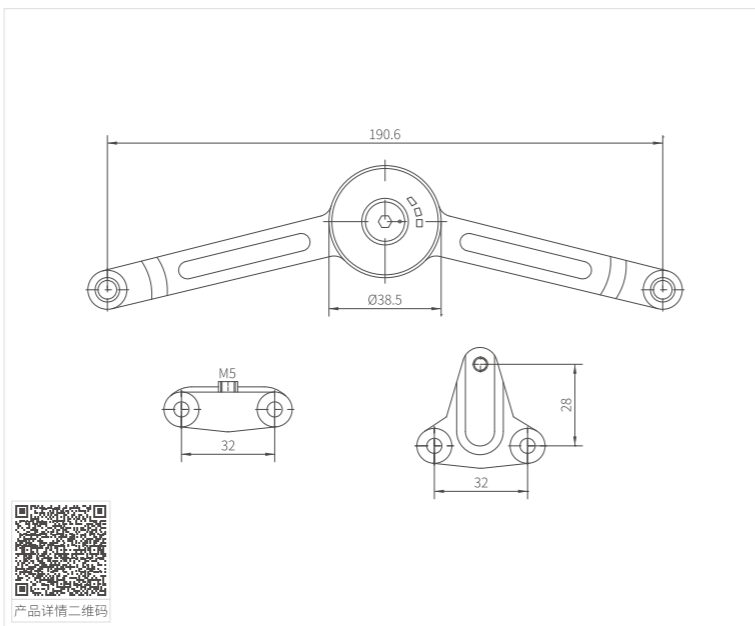

MK-WLS-3205 随意停支撑 MK-WLS-3205 Gas support



订货号 Item number	MK-WLS-3205
产品材质 Material	锌合金+铁+塑料 Zinc+iron+plastic
颜色可选 Finish	镍 Nickel plating

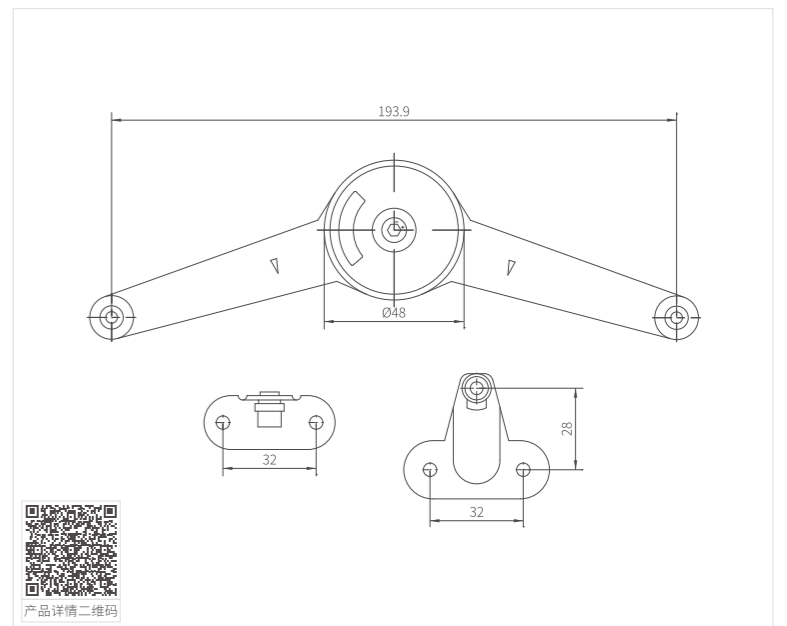

MK-WLS-3201B 随意停支撑 MK-WLS-3201B Gas support



订货号 Item number	MK-WLS-3201B
产品材质 Material	锌合金+铁+塑料 Zinc+iron+plastic
颜色可选 Finish	镍 Nickel plating

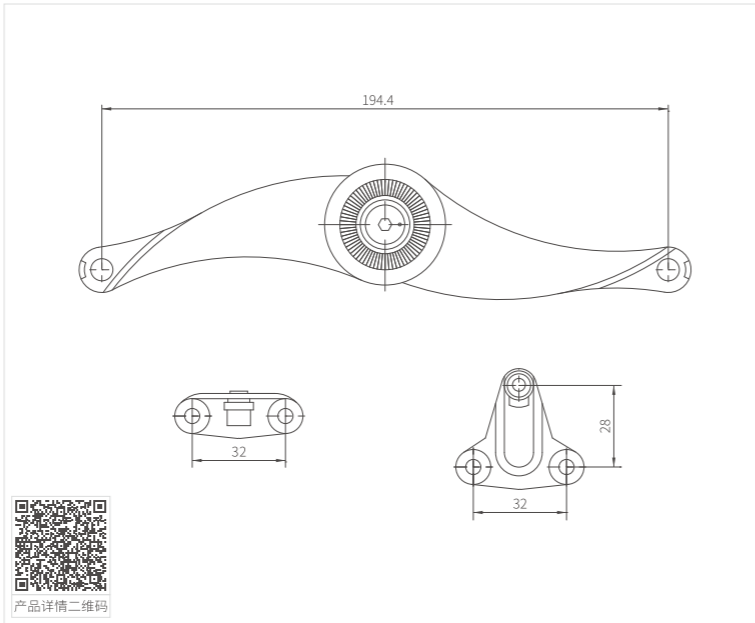

产品详情二维码

MK-WLS-3206 随意停支撑 MK-WLS-3206 Gas support



产品名称 Product name	随意停支撑 Gas support
订货号 Item number	MK-WLS-3206
材质 Material	锌合金+铁+塑料 Zinc+iron+plastic
颜色可选 Finish	镍 Nickel plating

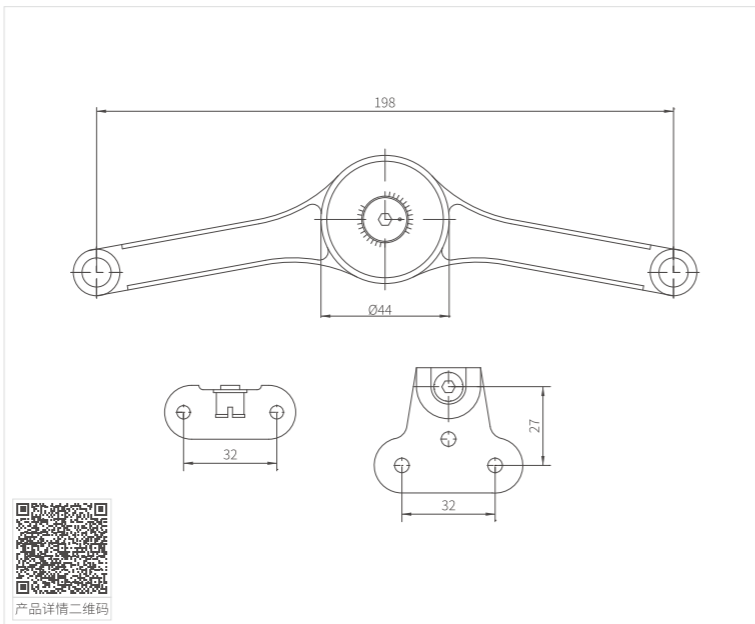

产品详情二维码

MK-WLS-3208 随意停支撑 MK-WLS-3208 Gas support



订货号 Item number	MK-WLS-3208
产品材质 Material	锌合金+铁+塑料 Zinc+iron+plastic
颜色可选 Finish	镍 Nickel plating

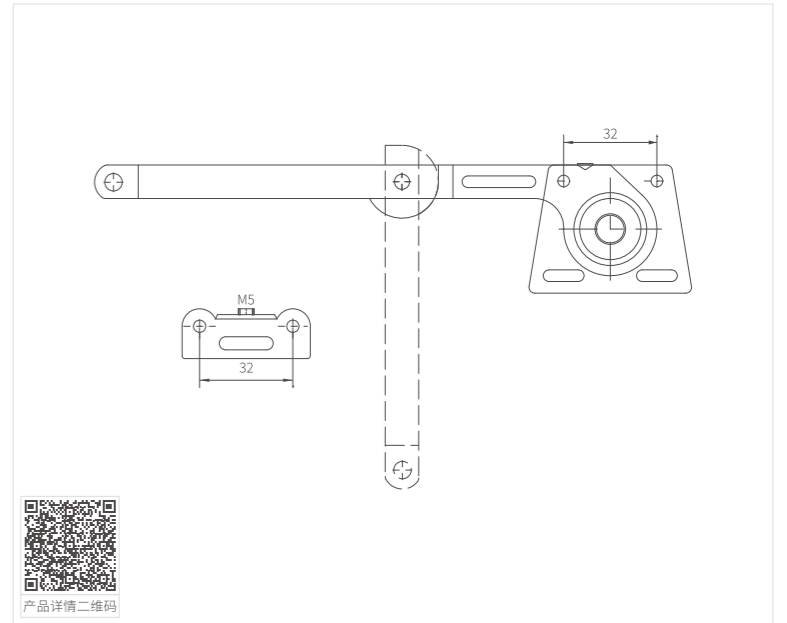

产品详情二维码





MeiKi明希®

ADJUSTABLE FOOT SERIES
可调脚系列

SMOOTH AND FIRM WITH FREE ADJUSTMENT
平稳牢靠 自由调节

随心调节柜体高度
不易打滑,减少与地面接触产生的磨损
Adjust cabinet height as desired
It is not easy to slip and reduce wear caused by contact with the ground

MK-TJJ-40-04-12 1#调节脚 MK-TJJ-40-04-12 Adjustable cabinet foot



订货号 Item number	MK-TJJ-40-04-12
产品材质 Material	塑料 Plastic
表面处理 Finish	黑色 Black

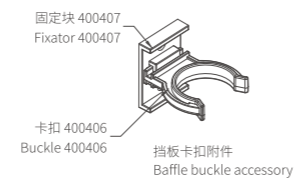
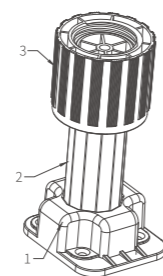
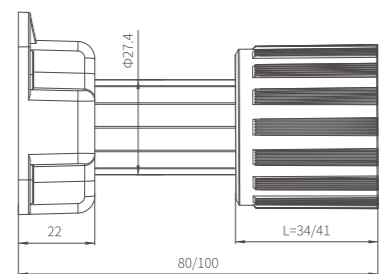
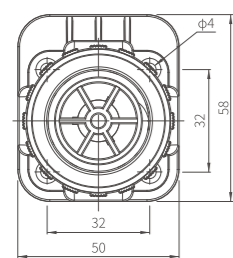

L80 调节范围75~95, L80 Adjustable range 75~95,
L100 调节范围 100~125 L100 Adjustable range 100~125

序号 Sequence number	代号 Code name	名称 Name	数量 Quantity	材料 Material	备注 Note
3	400411	旋钮 Knob L41	1	PP	
	400410	旋钮 Knob L34			
2	400412	立柱 Upright L80	1	PP	配: 厨柜调节脚旋钮 L34 Knob L34
	400413	立柱 Upright L100			配: 厨柜调节脚旋钮 L41 Knob L41
1	400408	固定座不带定位柱 Fixed base	1	PP	
		十字双层头纤维钉 4*16 Chipboard screw 4*16	4		镀 Nickel plating



产品详情二维码

MK-TJJ-40-04-04 2#调节脚 MK-TJJ-40-04-04 Adjustable cabinet foot



订货号 Item number	MK-TJJ-40-04-04
产品材质 Material	塑料 Plastic
表面处理 Finish	黑色 Black

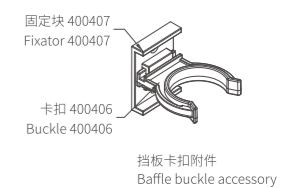
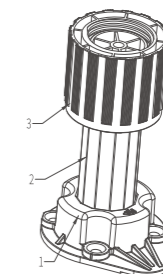
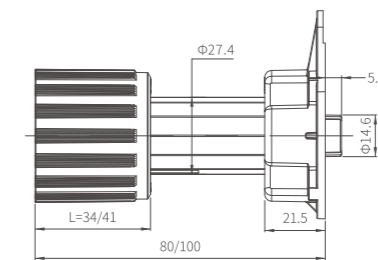
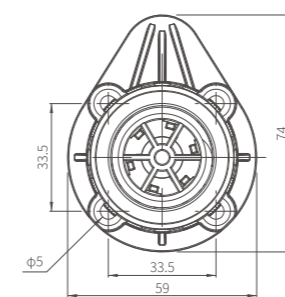

L80 调节范围75~95, L80 Adjustable range 75~95,
L100 调节范围 100~125 L100 Adjustable range 100~125

序号 Sequence number	代号 Code name	名称 Name	数量 Quantity	材料 Material	备注 Note
3	400403	旋钮 Knob L41	1	PP	
	400402	旋钮 Knob L34			
2	400404	立柱 Upright L80	1	PP	配: 厨柜调节脚旋钮 L34 Knob L34
	400405	立柱 Upright L100			配: 厨柜调节脚旋钮 L41 Knob L41
1	400401	固定座 Fixed base	1	PP	
		十字双层头纤维钉 4*16 Chipboard screw 4*16	4		镀 Nickel plating



产品详情二维码

MK-TH-100-130-CKF 橱柜可调脚 MK-TH-100-130-CKF Adjustable cabinet foot



订货号 Item number	MK-TH-100-130-CKF
产品材质 Material	塑料 Plastic
表面处理 Finish	黑色 Black

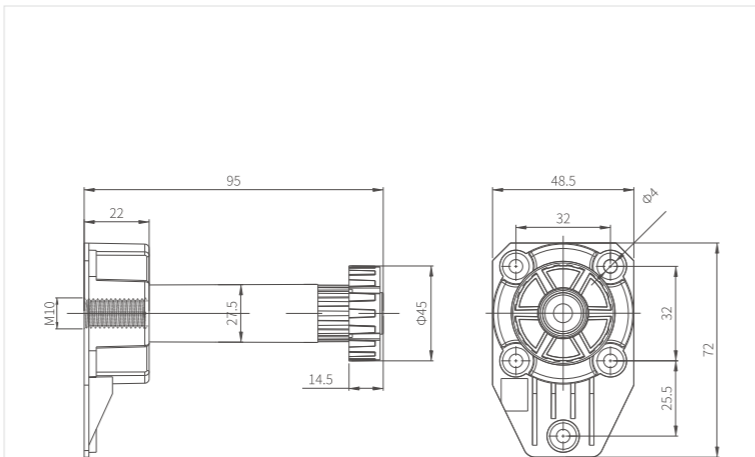

产品详情二维码

MK-TH-100-130-CKJ 橱柜可调脚 MK-TH-100-130-CKJ Adjustable cabinet foot



订货号 Item number	MK-TH-100-130-CKJ
产品材质 Material	塑料 Plastic
表面处理 Finish	黑色 Black

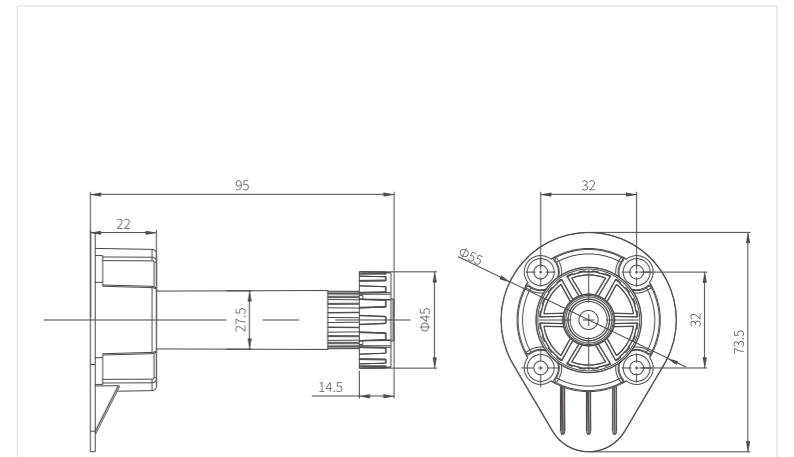

产品详情二维码

MK-TH-100-130-AK 橱柜可调脚 MK-TH-100-130-AK Adjustable cabinet foot



订货号 Item number	MK-TH-100-130-AK
产品材质 Material	塑料 Plastic
表面处理 Finish	黑色 Black

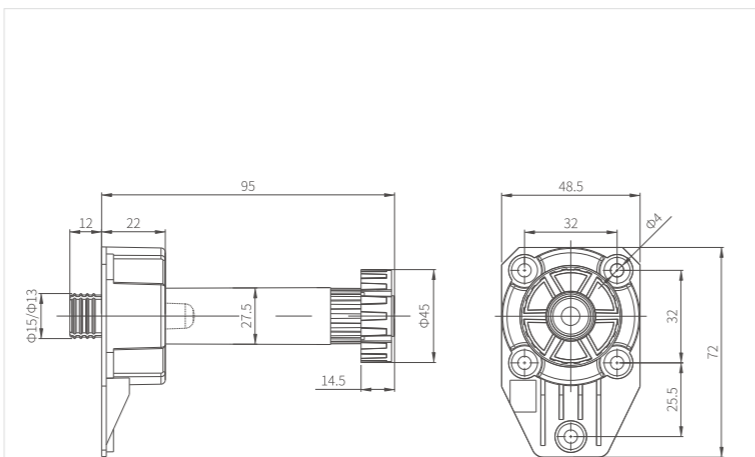

产品详情二维码

MK-SL-PH-10 橱柜可调脚 MK-SL-PH-10 Adjustable cabinet foot



订货号 Item number	MK-SL-PH-10
产品材质 Material	ABS
表面处理 Finish	黑色 Black

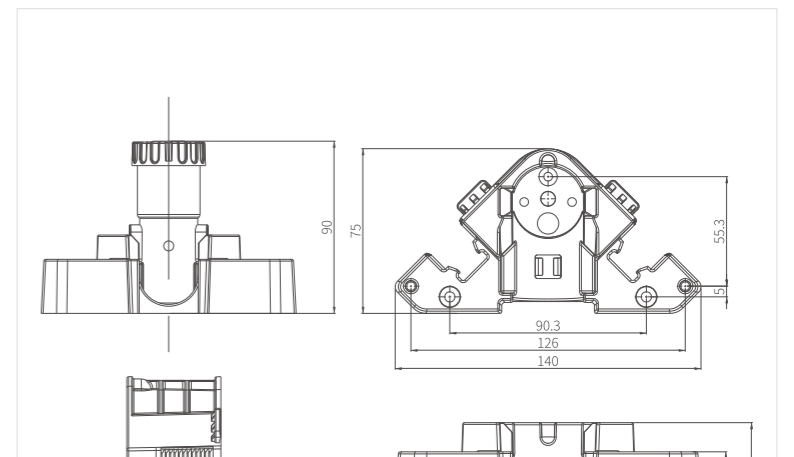

产品详情二维码

MK-SL-PH-11 橱柜可调脚 MK-SL-PH-11 Adjustable cabinet foot



订货号 Item number	MK-SL-PH-11
产品材质 Material	塑料 Plastic
表面处理 Finish	黑色 Black

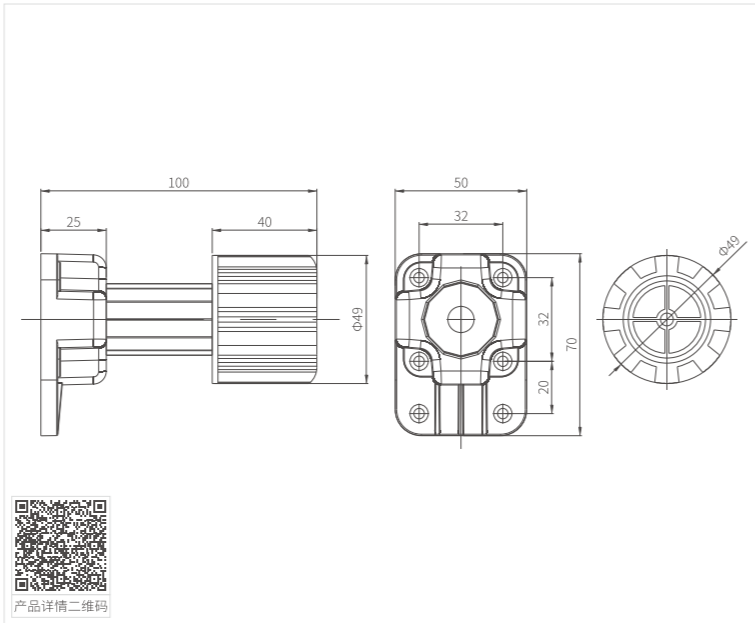

MK-SL-PH-07 橱柜可调脚 MK-SL-PH-07 Adjustable cabinet foot



订货号 Item number	MK-SL-PH-07
产品材质 Material	塑料 Plastic
表面处理 Finish	黑色 Black

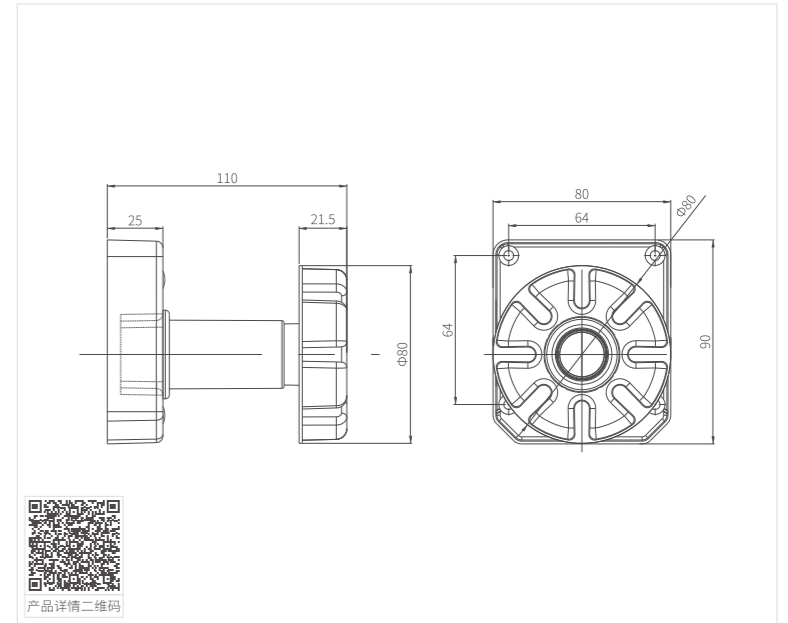

MK-SL-PH-12 橱柜可调脚 MK-SL-PH-12 Adjustable cabinet foot



订货号 Item number	MK-SL-PH-12
产品材质 Material	塑料 Plastic
表面处理 Finish	黑色 Black

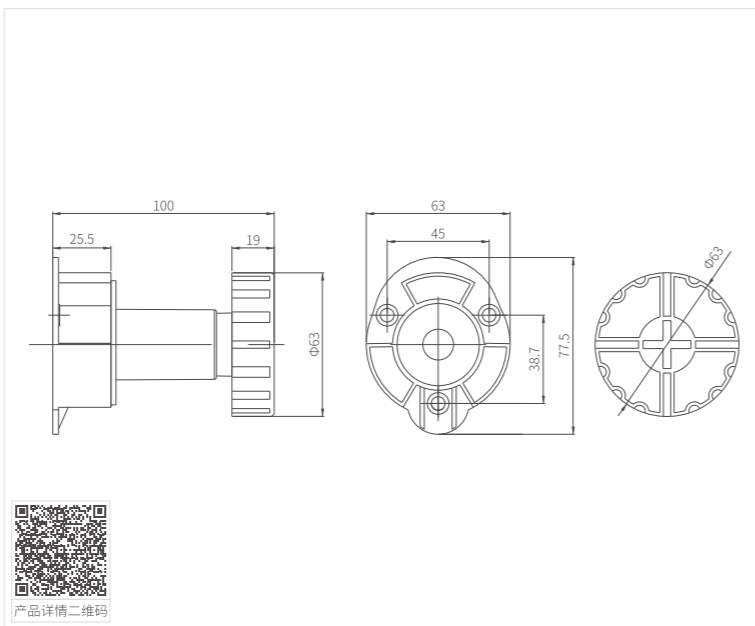

MK-PG-50-80 橱柜可调脚 MK-PG-50-80 Adjustable cabinet foot



订货号 Item number	MK-PG-50-80
产品材质 Material	ABS
表面处理 Finish	黑色 Black

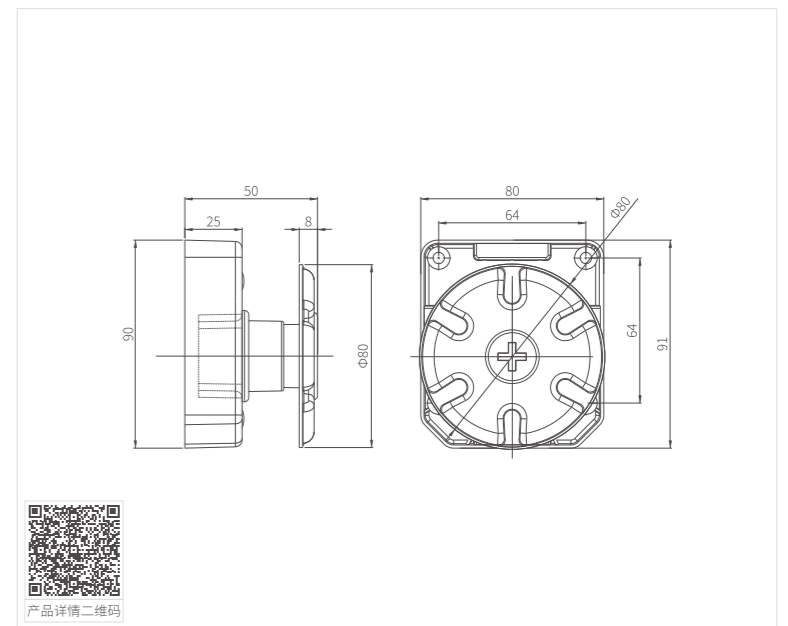

MK-YG-40-04-20 衣柜调节脚 MK-YG-40-04-20 Adjustable cabinet foot



订货号 Item number	MK-YG-40-04-20
产品材质 Material	塑料+碳钢 Plastic + Carbon steel
表面处理 Finish	黑色+蓝白锌 Black+ Blue zinc

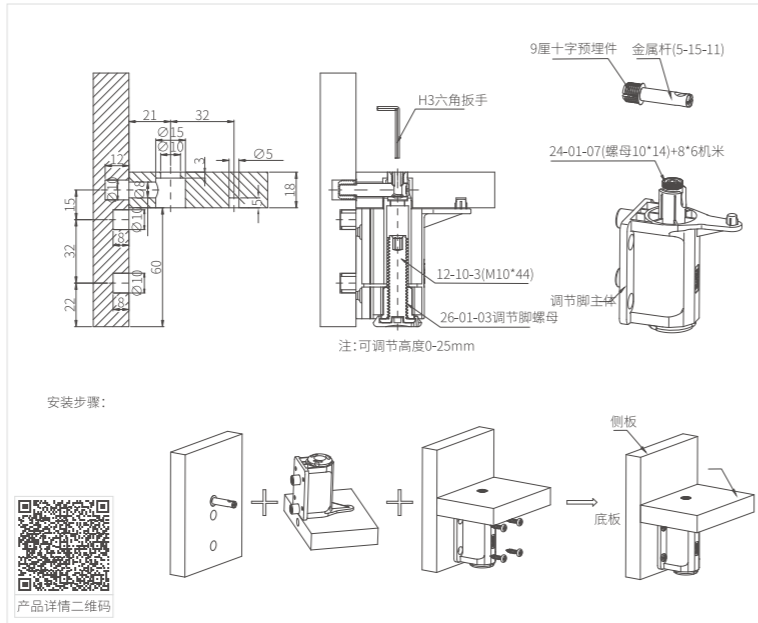

产品详情二维码

MK-YG-40-04-22 衣柜调节脚 MK-YG-40-04-22 Adjustable cabinet foot



订货号 Item number	MK-YG-40-04-22
产品材质 Material	塑料+碳钢 Plastic + Carbon steel
表面处理 Finish	黑色+蓝白锌 Black+ Blue zinc

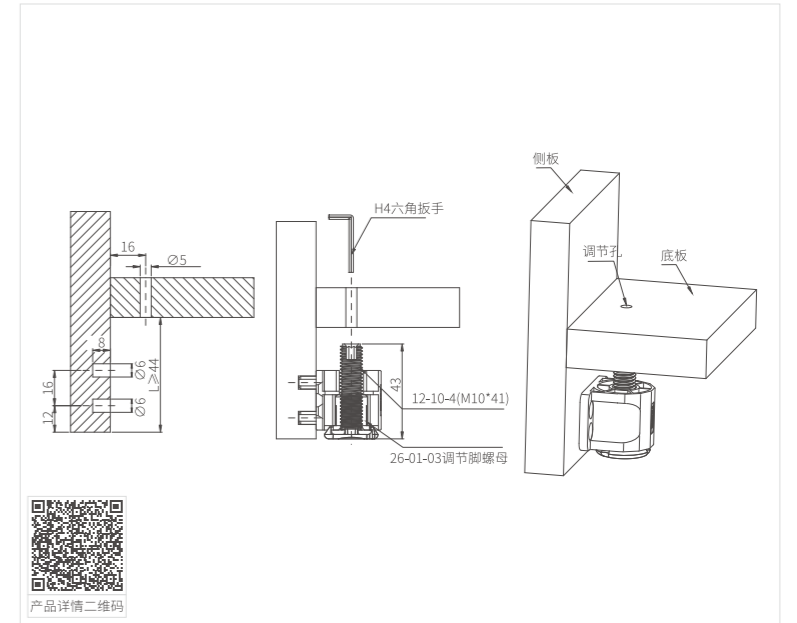

产品详情二维码

MK-YG-40-04-21 衣柜调节脚 MK-YG-40-04-21 Adjustable cabinet foot



订货号 Item number	MK-YG-40-04-21
产品材质 Material	塑料+碳钢 Plastic + Carbon steel
表面处理 Finish	黑色+蓝白锌 Black+ Blue zinc

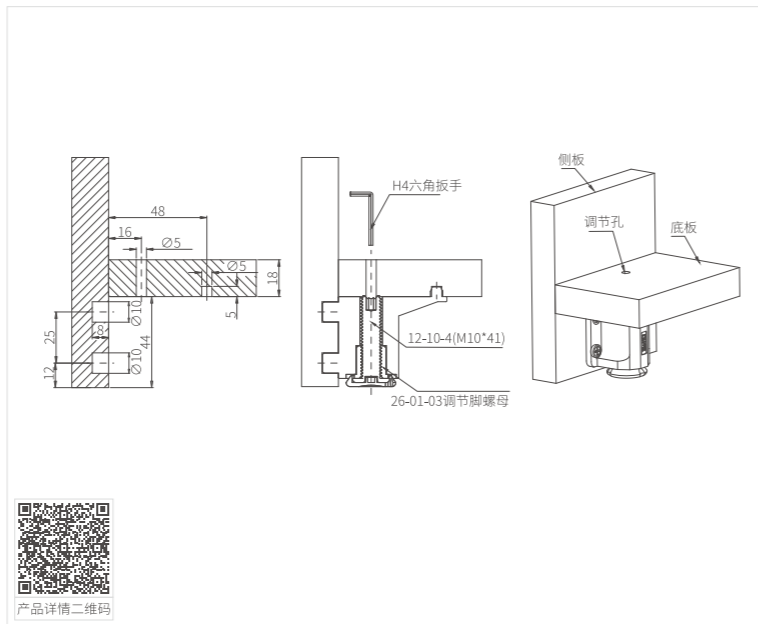

产品详情二维码

MK-SD-DBT-01 大班台可调脚 MK-SD-DBT-01 Adjustable foot



订货号 Item number	MK-SD-DBT-01
产品材质 Material	冷轧钢+碳钢 Cold rolled steel+carbon steel
表面处理 Finish	蓝白锌 Blue zinc

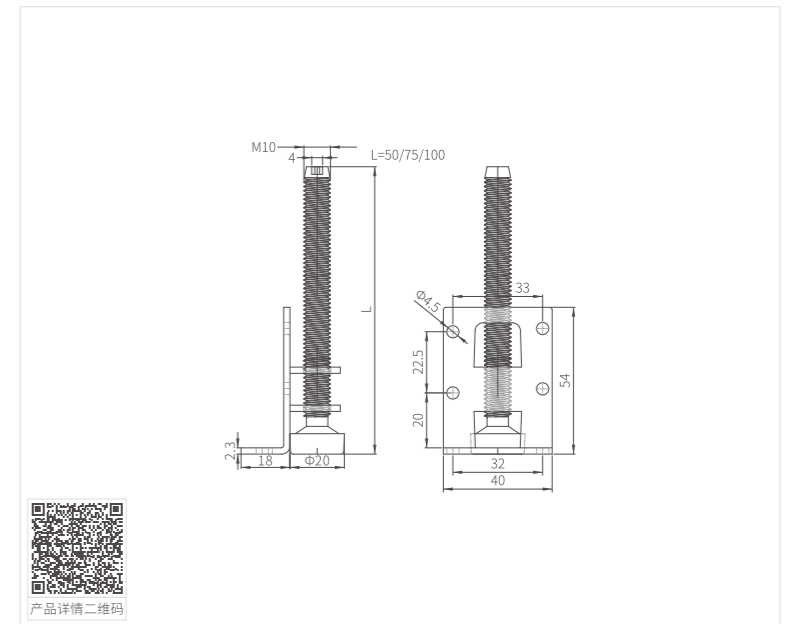

产品详情二维码

MK-SD-02 大可调脚 MK-SD-02 Large adjustable foot



订货号 Item number	MK-SD-02
产品材质 Material	冷轧钢+碳钢 Cold rolled steel+carbon steel
表面处理 Finish	蓝白锌 Blue zinc

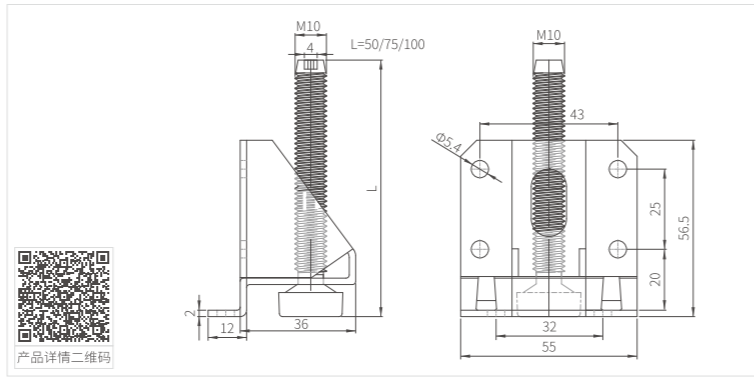

MK-DG-30 30可调脚 MK-DG-30 30 Adjustable foot



订货号 Item number	MK-DG-30
产品材质 Material	锌合金+塑料 Zinc alloy+plastic
表面处理 Finish	蓝白锌 Blue zinc

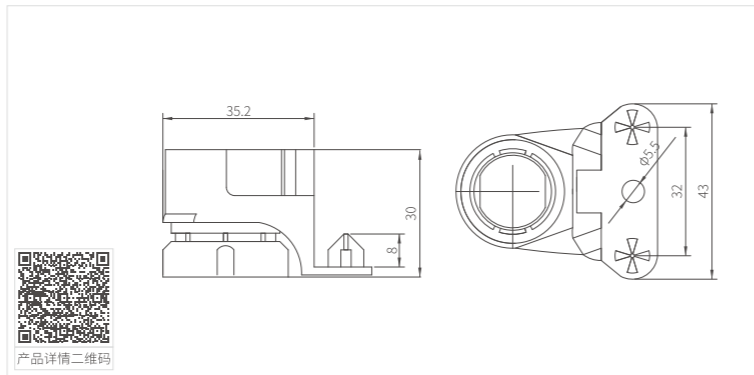

MK-GH-TJJ-8*25 可调脚 MK-GH-TJJ-8*25 Adjustable foot



订货号 Item number	MK-GH-TJJ-8*25
产品材质 Material	锌合金+碳钢+塑料 Zinc alloy + carbon steel + plastic
表面处理 Finish	蓝白锌 Blue zinc

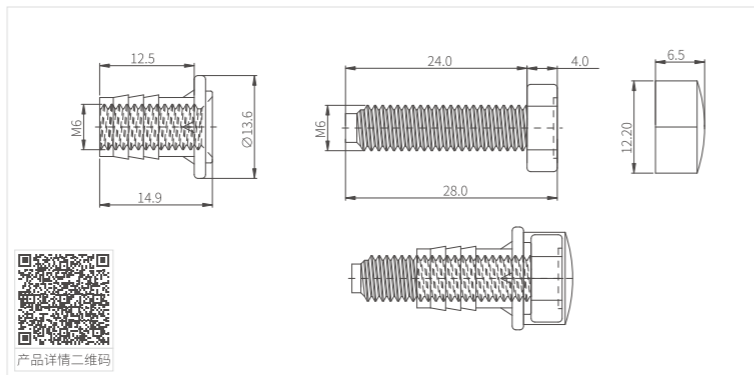

MK-XQ-SX-6*13 三线平面可调脚 MK-XQ-SX-6*13 Adjustable foot



订货号 Item number	MK-XQ-SX-6*13
产品材质 Material	铁+塑料 Iron+plastic
表面处理 Finish	黑色 Black

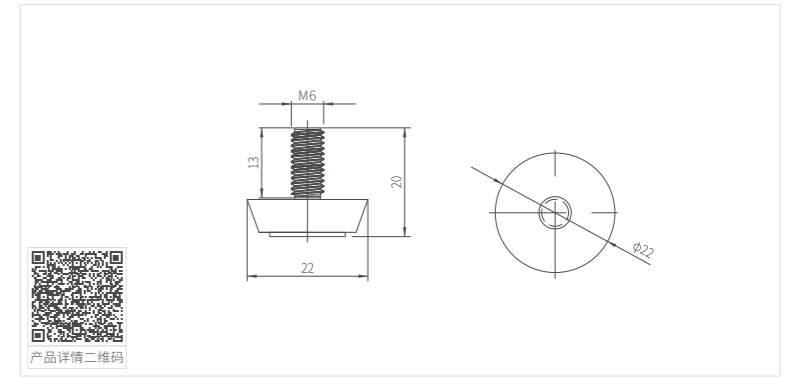

MK-XQ-BXG-8*20 不锈钢可调脚 MK-XQ-BXG-8*20 Adjustable foot



订货号 Item number	MK-XQ-BXG-8*20
产品材质 Material	铁+塑料 Iron+plastic
表面处理 Finish	黑色 Black

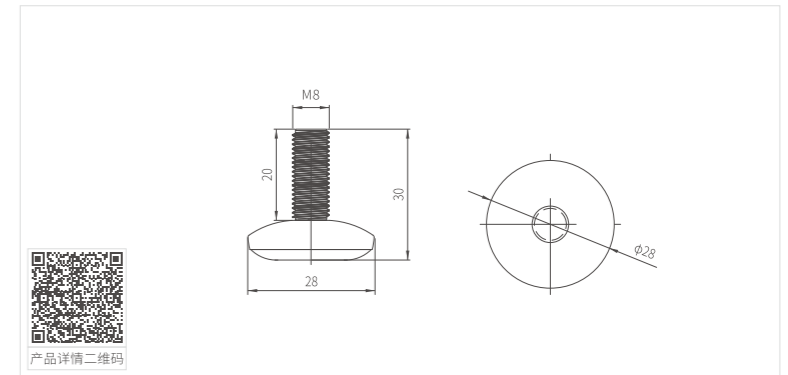

MK-XQ-0306 可调脚 MK-XQ-0306 Adjustable foot



订货号 Item number	MK-XQ-0306
产品材质 Material	铁+塑料 Iron+plastic
表面处理 Finish	白锌 White zinc、黑色 Black

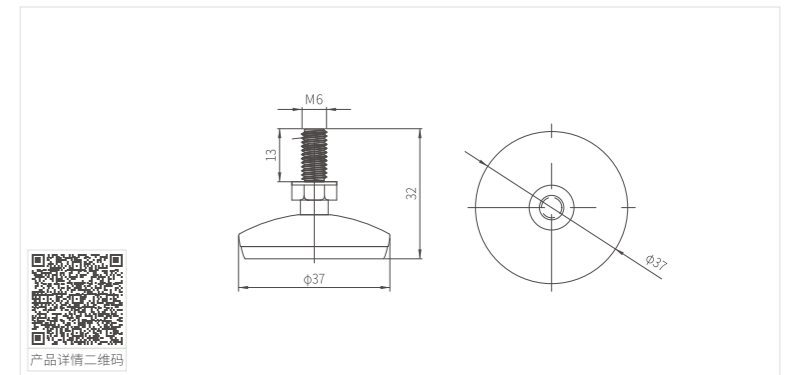

MK-XQ-5501 活动可调脚 MK-XQ-5501 Adjustable foot



订货号 Item number	MK-XQ-5501
产品材质 Material	铁+塑料 Iron+plastic
表面处理 Finish	银色+黑色 Silver+Black

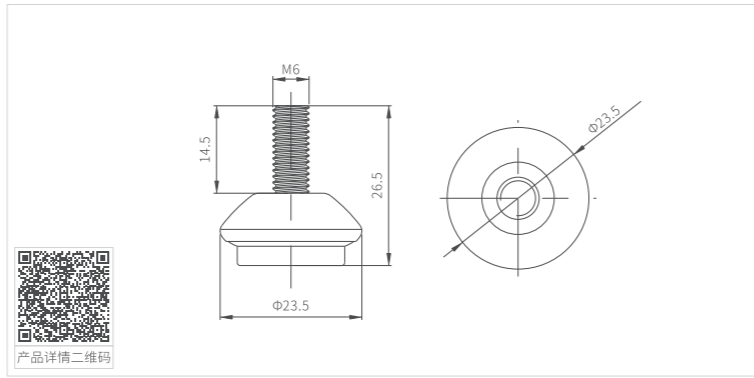

MK-XQ-5502 活动可调脚 MK-XQ-5502 Adjustable foot



订货号 Item number	MK-XQ-5502
产品材质 Material	铁+塑料 Iron+plastic
表面处理 Finish	银色+黑色 Silver+Black

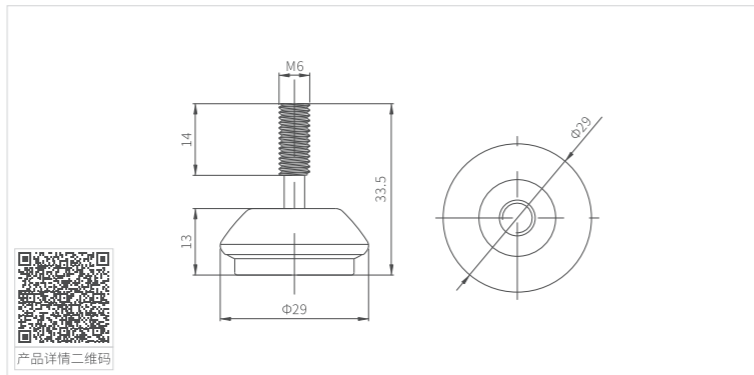

MK-XQ-5503 活动可调脚 MK-XQ-5503 Adjustable foot



订货号 Item number	MK-XQ-5503
产品材质 Material	铁+塑料 Iron+plastic
表面处理 Finish	银色+黑色 Silver+Black

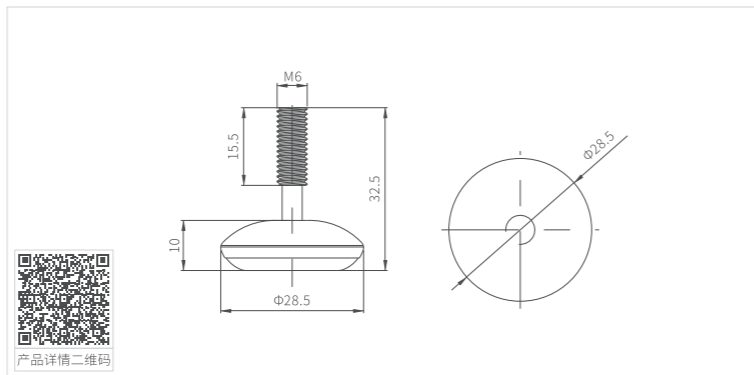

MK-XQ-5601 活动可调脚 MK-XQ-5601 Adjustable foot



订货号 Item number	MK-XQ-5601
产品材质 Material	铁+塑料 Iron+plastic
表面处理 Finish	银色+黑色 Silver+Black

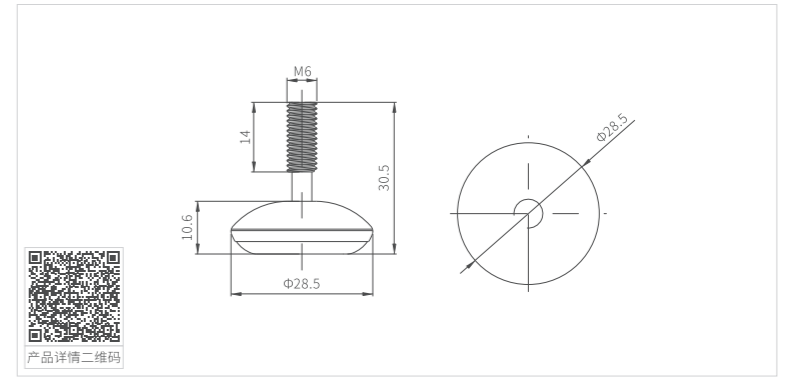

MK-XQ-5602 活动可调脚 MK-XQ-5602 Adjustable foot



订货号 Item number	MK-XQ-5602
产品材质 Material	铁+塑料 Iron+plastic
表面处理 Finish	银色+黑色 Silver+Black

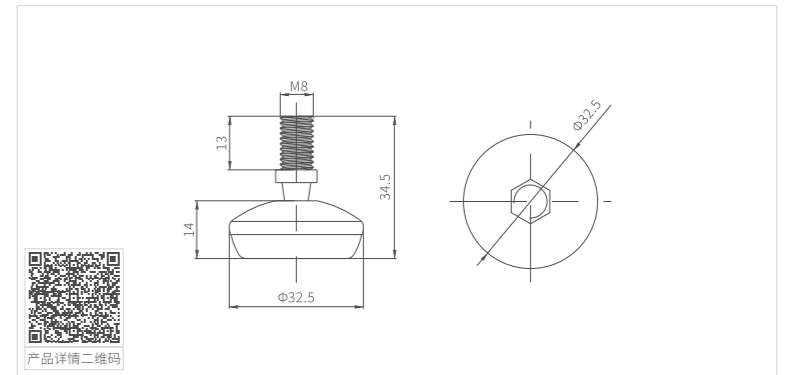

MK-XQ-5701 活动可调脚 MK-XQ-5701 Adjustable foot



订货号 Item number	MK-XQ-5701
产品材质 Material	铁+塑料 Iron+plastic
表面处理 Finish	银色+黑色 Silver+Black

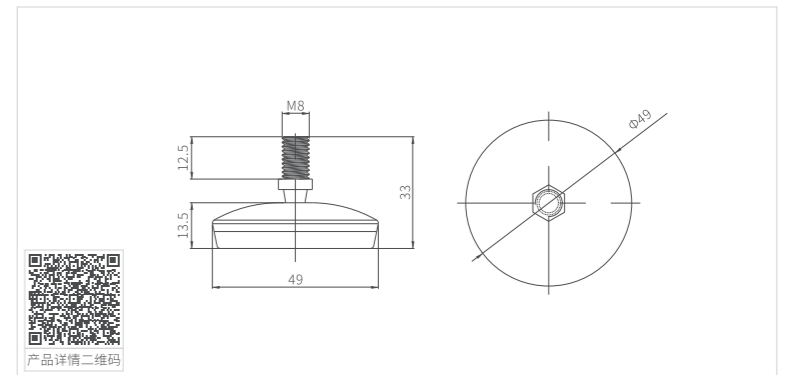

MK-XQ-5702 活动可调脚 MK-XQ-5702 Adjustable foot



订货号 Item number	MK-XQ-5702
产品材质 Material	铁+塑料 Iron+plastic
表面处理 Finish	银色+黑色+白色 Silver+Black+White

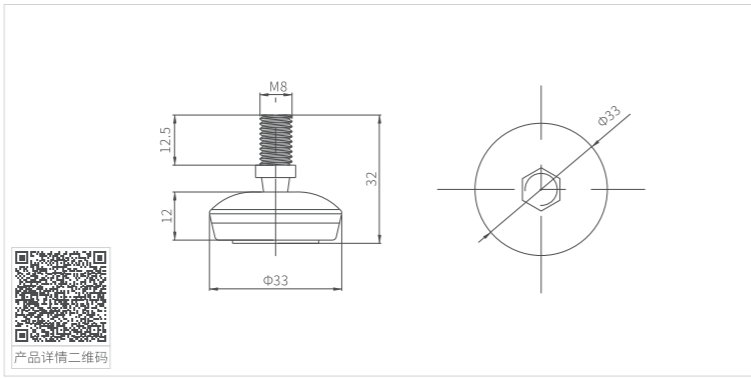

产品详情二维码

MK-XQ-5801 固定可调脚 MK-XQ-5801 Fixed adjustable foot



订货号 Item number	MK-XQ-5801
产品材质 Material	铁+塑料 Iron+plastic
表面处理 Finish	银色+白色 Silver+White

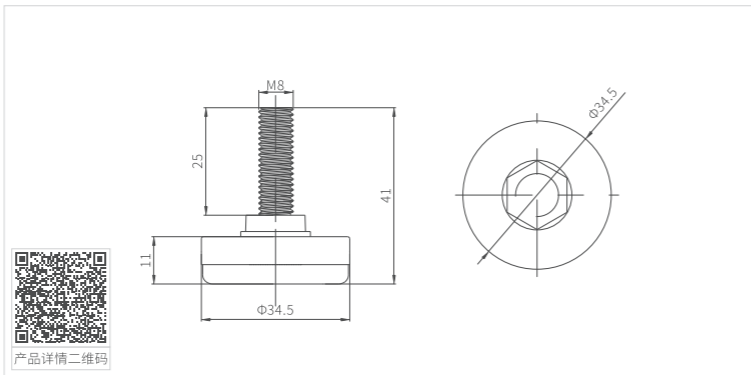

产品详情二维码

MK-XQ-5901 固定可调脚 MK-XQ-5901 Fixed adjustable foot



订货号 Item number	MK-XQ-5901
产品材质 Material	铁+塑料 Iron+plastic
表面处理 Finish	银色+白色 Silver+White

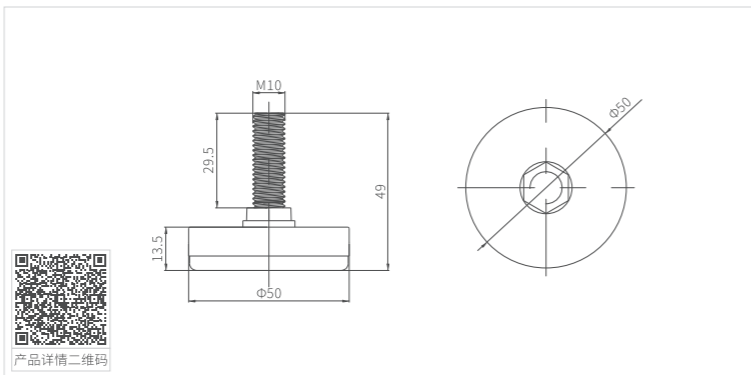

产品详情二维码

MK-XQ-5902 活动可调脚 MK-XQ-5902 Adjustable foot



订货号 Item number	MK-XQ-5902
产品材质 Material	铁+塑料 Iron+plastic
表面处理 Finish	银色+黑色 Silver+Black

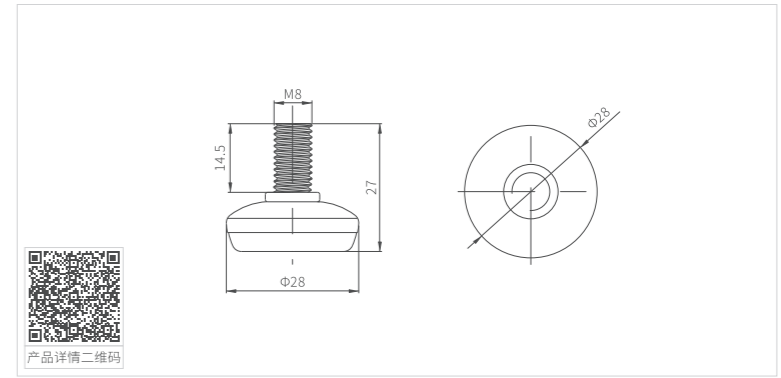

产品详情二维码

MK-XQ-5903 活动可调脚 MK-XQ-5903 Adjustable foot



订货号 Item number	MK-XQ-5903
产品材质 Material	铁+塑料 Iron+plastic
表面处理 Finish	银色+黑色 Silver+Black

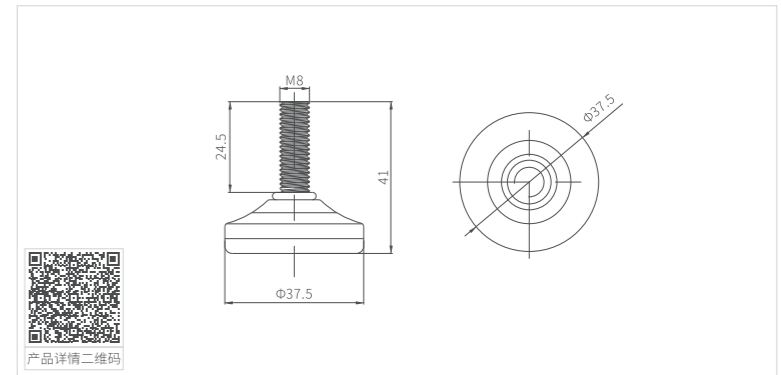

产品详情二维码

MK-XQ-6002 固定可调脚 MK-XQ-6002 Fixed adjustable foot



订货号 Item number	MK-XQ-6002
产品材质 Material	铁+塑料 Iron+plastic
表面处理 Finish	黑色+白色 Black+White

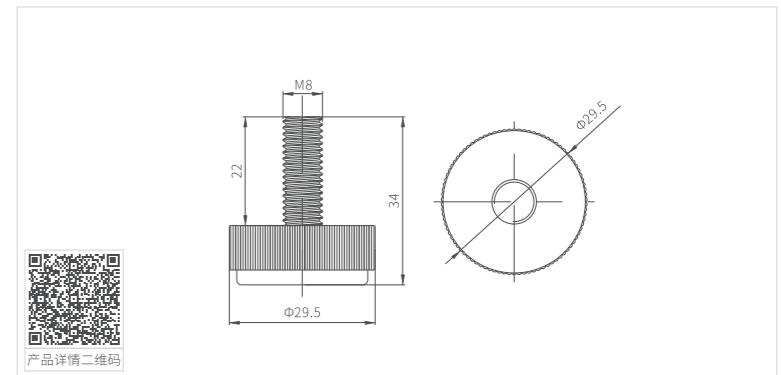

产品详情二维码

MK-XQ-6003 固定可调脚 MK-XQ-6003 Fixed adjustable foot



订货号 Item number	MK-XQ-6003
产品材质 Material	铁+塑料 Iron+plastic
表面处理 Finish	银色+黑色 Silver+Black

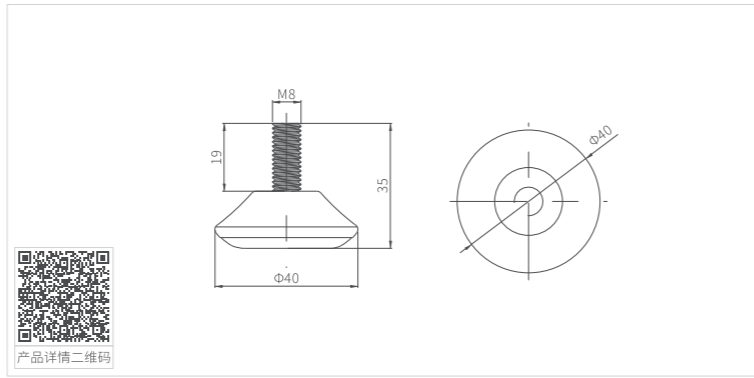

产品详情二维码

MK-XQ-6104 活动可调脚 MK-XQ-6104 Adjustable foot



订货号 Item number	MK-XQ-6104
产品材质 Material	铁+塑料 Iron+plastic
表面处理 Finish	银色+黑色 Silver+Black

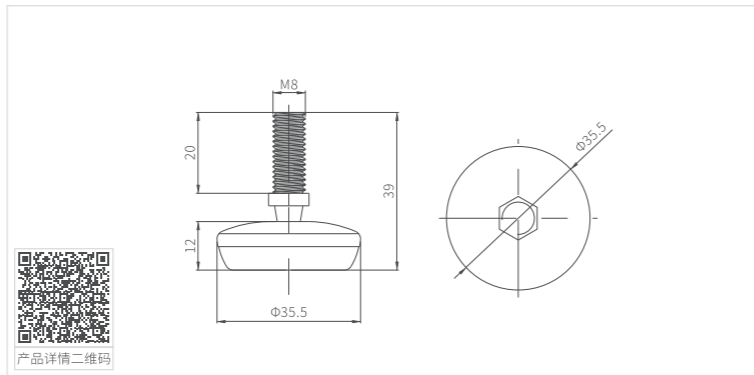

产品详情二维码

MK-XQ-6105 活动可调脚 MK-XQ-6105 Adjustable foot



订货号 Item number	MK-XQ-6105
产品材质 Material	铁+塑料 Iron+plastic
表面处理 Finish	银色+黑色 Silver+Black

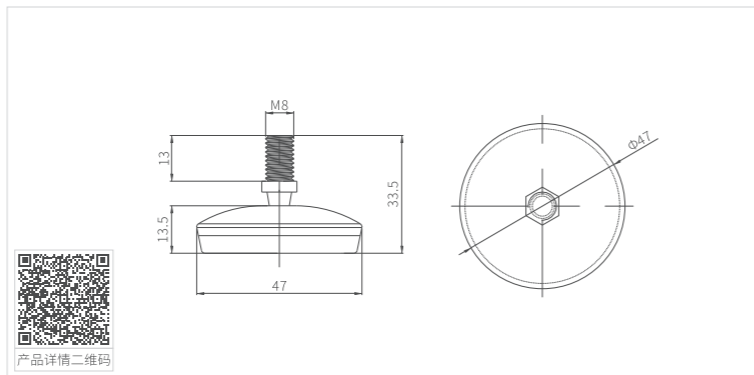

产品详情二维码

MK-XQ-6302 活动可调脚 MK-XQ-6302 Adjustable foot



订货号 Item number	MK-XQ-6302
产品材质 Material	铁+塑料 Iron+plastic
表面处理 Finish	银色+黑色 Silver+Black

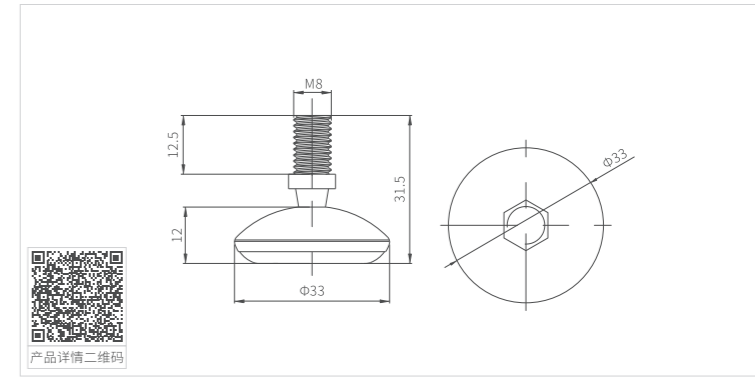

产品详情二维码

MK-XQ-6304 活动可调脚 MK-XQ-6304 Adjustable foot



订货号 Item number	MK-XQ-6304
产品材质 Material	铁+塑料 Iron+plastic
表面处理 Finish	银色+黑色 Silver+Black

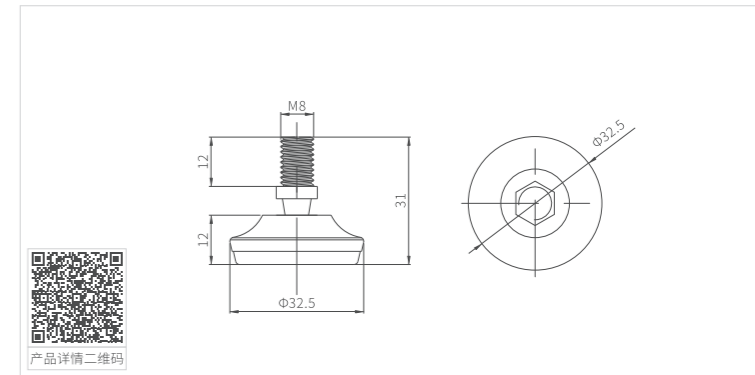

产品详情二维码

MK-XQ-6305 活动可调脚 MK-XQ-6305 Adjustable foot



订货号 Item number	MK-XQ-6305
产品材质 Material	铁+塑料 Iron+plastic
表面处理 Finish	银色+黑色 Silver+Black

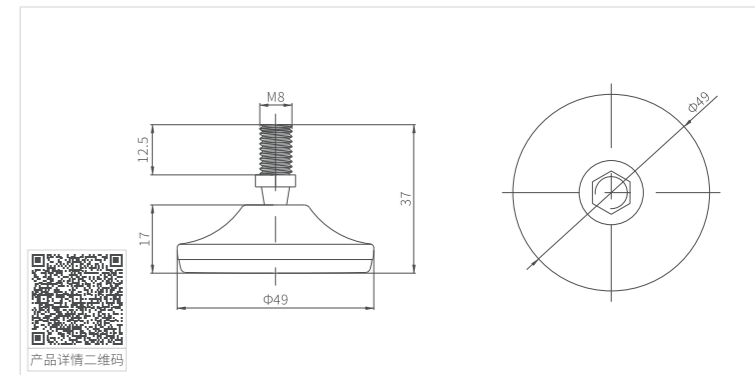

产品详情二维码

MK-XQ-6402活动可调脚 MK-XQ-6402 Adjustable foot



订货号 Item number	MK-XQ-6402
产品材质 Material	铁+塑料 Iron+plastic
表面处理 Finish	银色+黑色 Silver+Black

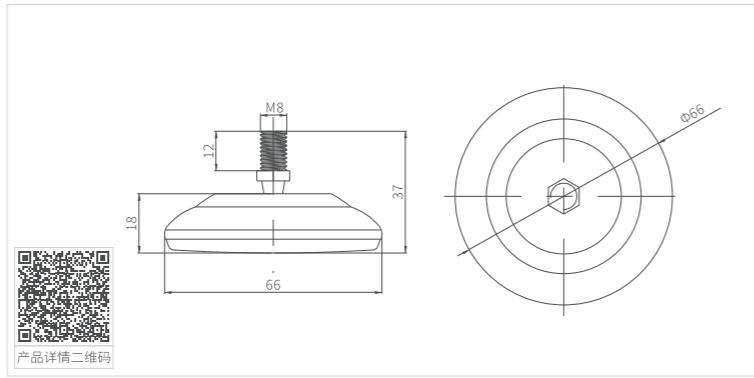

MK-XQ-6403 活动可调脚 MK-XQ-6403 Adjustable foot



订货号 Item number	MK-XQ-6403
产品材质 Material	铁+塑料 Iron+plastic
表面处理 Finish	黑色 Black

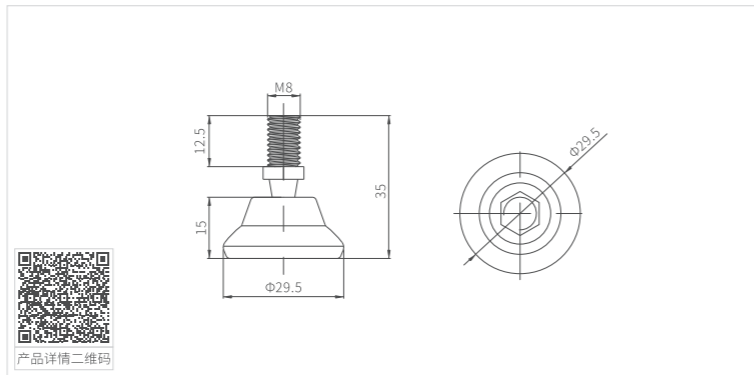

MK-XQ-6404 活动可调脚 MK-XQ-6404 Adjustable foot



订货号 Item number	MK-XQ-6404
产品材质 Material	铁+塑料 Iron+plastic
表面处理 Finish	黑色 Black

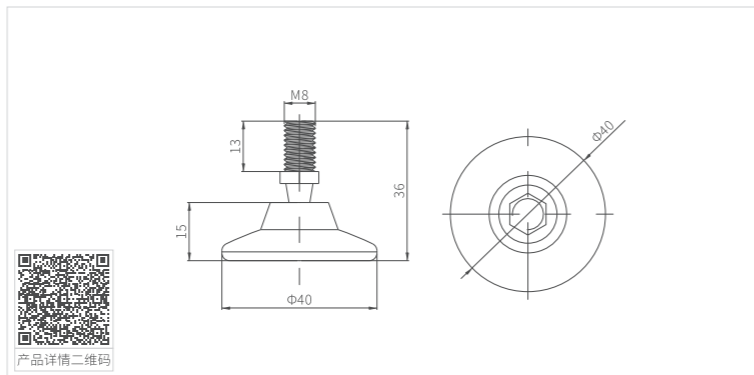

MK-XQ-6604 固定可调脚 MK-XQ-6604 Fixed adjustable foot



订货号 Item number	MK-XQ-6604
产品材质 Material	铁+塑料 Iron+plastic
表面处理 Finish	黑色+透明白 Black+Transparent

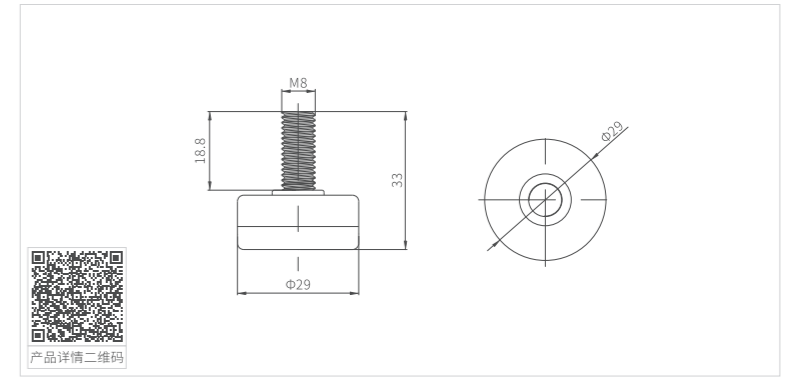

MK-XQ-6605 固定可调脚 MK-XQ-6605 Fixed adjustable foot



订货号 Item number	MK-XQ-6605
产品材质 Material	铁+塑料 Iron+plastic
表面处理 Finish	黑色 Black

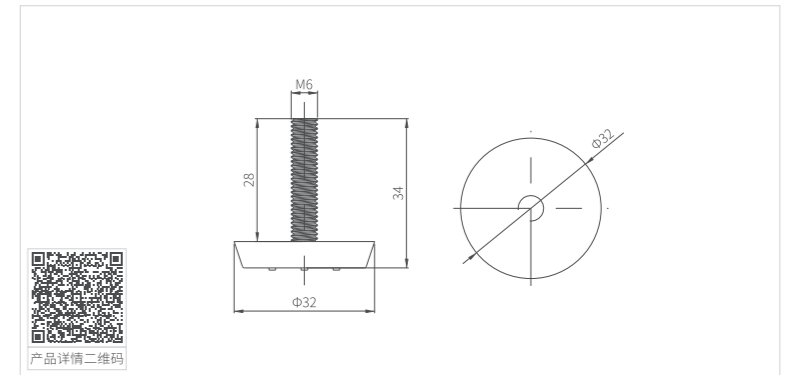

MK-XQ-6702 固定可调脚 MK-XQ-6702 Fixed adjustable foot



订货号 Item number	MK-XQ-6702
产品材质 Material	铁+塑料 Iron+plastic
表面处理 Finish	黑色 Black

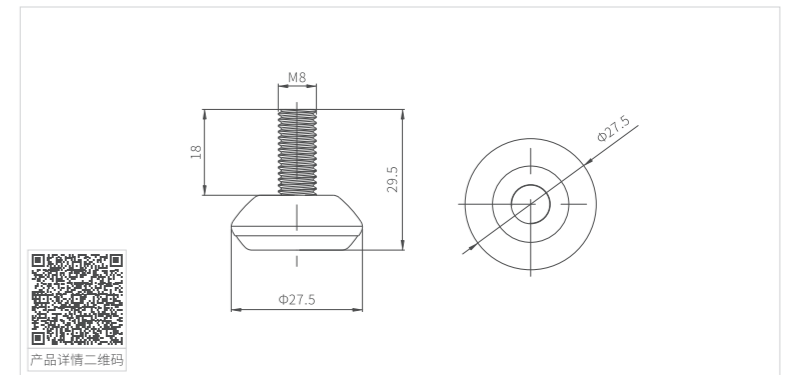

MK-XQ-6703 固定可调脚 MK-XQ-6703 Fixed adjustable foot



订货号 Item number	MK-XQ-6703
产品材质 Material	铁+塑料 Iron+plastic
表面处理 Finish	银色+黑色 Silver+Black

产品详情二维码

MK-XQ-6704 固定可调脚 MK-XQ-6704 Fixed adjustable foot



订货号 Item number	MK-XQ-6704
产品材质 Material	铁+塑料 Iron+plastic
表面处理 Finish	黑色 Black

产品详情二维码

MK-XQ-6705 固定可调脚 MK-XQ-6705 Fixed adjustable foot



订货号 Item number	MK-XQ-6705
产品材质 Material	铁+塑料 Iron+plastic
表面处理 Finish	黑色 Black

产品详情二维码

MK-XQ-6801 固定可调脚 MK-XQ-6801 Fixed adjustable foot



订货号 Item number	MK-XQ-6801
产品材质 Material	铁+塑料 Iron+plastic
表面处理 Finish	黑色 Black

产品详情二维码

MK-XQ-6802 固定可调脚 MK-XQ-6802 Fixed adjustable foot



订货号 Item number	MK-XQ-6802
产品材质 Material	铁+塑料 Iron+plastic
表面处理 Finish	黑色 Black

产品详情二维码

MK-XQ-6804 固定可调脚 MK-XQ-6804 Fixed adjustable foot



订货号 Item number	MK-XQ-6804
产品材质 Material	铁+塑料 Iron+plastic
表面处理 Finish	黑色 Black

产品详情二维码

MK-XQ-7105 固定可调脚 MK-XQ-7105 Fixed adjustable foot



订货号 Item number	MK-XQ-7105
产品材质 Material	铁+塑料 Iron+plastic
表面处理 Finish	黑色 Black

产品详情二维码

MK-XQ-7101 固定可调脚 MK-XQ-7101 Fixed adjustable foot



订货号 Item number	MK-XQ-7101
产品材质 Material	铁+塑料 Iron+plastic
表面处理 Finish	黑色 Black

产品详情二维码

MK-XQ-7104 固定可调脚 MK-XQ-7104 Fixed adjustable foot



订货号 Item number	MK-XQ-7104
产品材质 Material	铁+塑料 Iron+plastic
表面处理 Finish	黑色 Black

产品详情二维码

MK-XQ-7201 固定可调脚 MK-XQ-7201 Fixed adjustable foot



订货号 Item number	MK-XQ-7201
产品材质 Material	铁+塑料 Iron+plastic
表面处理 Finish	黑色 Black

产品详情二维码

MK-XQ-7103 固定可调脚 MK-XQ-7103 Fixed adjustable foot



订货号 Item number	MK-XQ-7103
产品材质 Material	铁+塑料 Iron+plastic
表面处理 Finish	黑色 Black

产品详情二维码

MK-XQ-7202 固定可调脚 MK-XQ-7202 Fixed adjustable foot



订货号 Item number	MK-XQ-7202
产品材质 Material	铁+塑料 Iron+plastic
表面处理 Finish	黑色 Black

产品详情二维码

MK-XQ-7203 固定可调脚 MK-XQ-7203 Fixed adjustable foot



订货号 Item number	MK-XQ-7203
产品材质 Material	铁+塑料 Iron+plastic
表面处理 Finish	黑色 Black

产品详情二维码

MK-XQ-7303 固定可调脚 MK-XQ-7303 Fixed adjustable foot



订货号 Item number	MK-XQ-7303
产品材质 Material	铁+塑料 Iron+plastic
表面处理 Finish	黑色 Black

产品详情二维码

MK-XQ-7204 固定可调脚 MK-XQ-7204 Fixed adjustable foot



订货号 Item number	MK-XQ-7204
产品材质 Material	铁+塑料 Iron+plastic
表面处理 Finish	黑色 Black

产品详情二维码

MK-XQ-7305 固定可调脚 MK-XQ-7305 Fixed adjustable foot



订货号 Item number	MK-XQ-7305
产品材质 Material	铁+塑料 Iron+plastic
表面处理 Finish	黑色 Black

产品详情二维码

MK-XQ-7302 固定可调脚 MK-XQ-7302 Fixed adjustable foot



订货号 Item number	MK-XQ-7302
产品材质 Material	铁+塑料 Iron+plastic
表面处理 Finish	黑色 Black

产品详情二维码

MK-XQ-7301 固定可调脚 MK-XQ-7301 Fixed adjustable foot



订货号 Item number	MK-XQ-7301
产品材质 Material	铁+塑料 Iron+plastic
表面处理 Finish	黑色 Black

产品详情二维码

MK-XQ-7403 固定可调脚 MK-XQ-7403 Fixed adjustable foot



订货号 Item number	MK-XQ-7403
产品材质 Material	铁+塑料 Iron+plastic
表面处理 Finish	黑色 Black

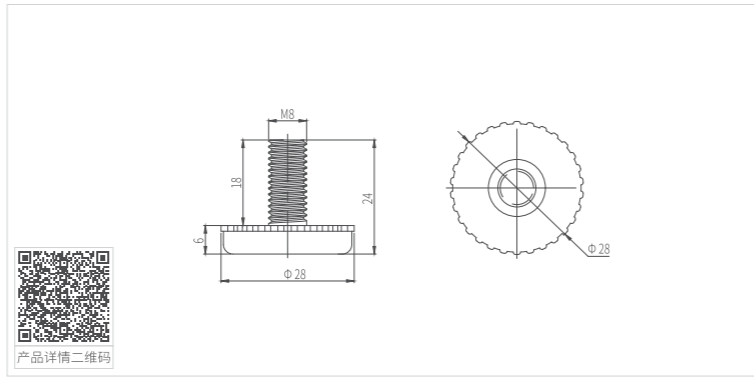

产品详情二维码

MK-XQ-7404 固定可调脚 MK-XQ-7404 Fixed adjustable foot



订货号 Item number	MK-XQ-7404
产品材质 Material	铁+塑料 Iron+plastic
表面处理 Finish	黑色 Black

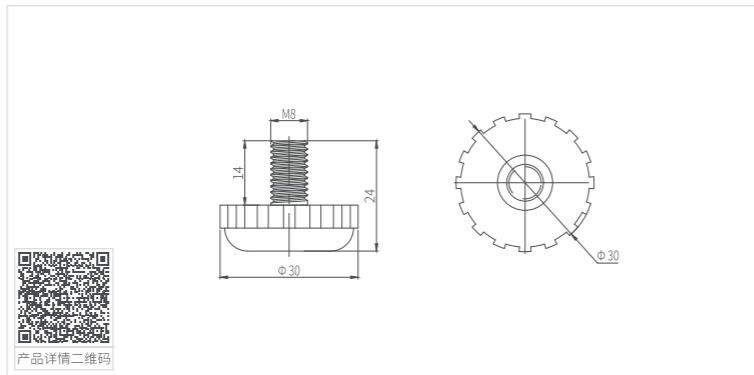

产品详情二维码

MK-XQ-7502 固定可调脚 MK-XQ-7502 Fixed adjustable foot



订货号 Item number	MK-XQ-7502
产品材质 Material	铁+塑料 Iron+plastic
表面处理 Finish	黑色 Black

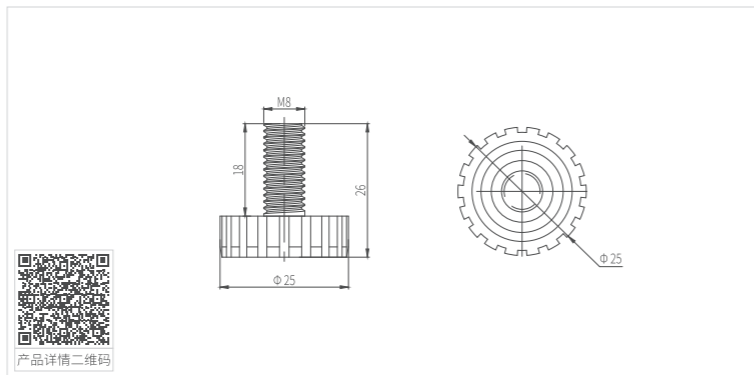

产品详情二维码

MK-XQ-7503 固定可调脚 MK-XQ-7503 Fixed adjustable foot



订货号 Item number	MK-XQ-7503
产品材质 Material	铁+塑料 Iron+plastic
表面处理 Finish	黑色 Black

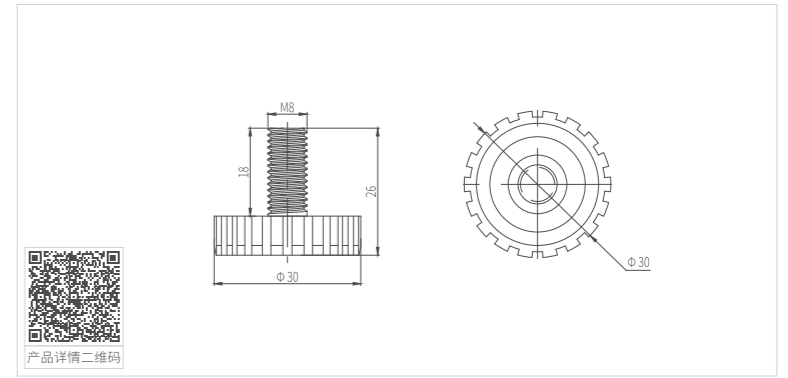

产品详情二维码

MK-XQ-7601 固定可调脚 MK-XQ-7601 Fixed adjustable foot



订货号 Item number	MK-XQ-7601
产品材质 Material	铁+塑料 Iron+plastic
表面处理 Finish	黑色 Black

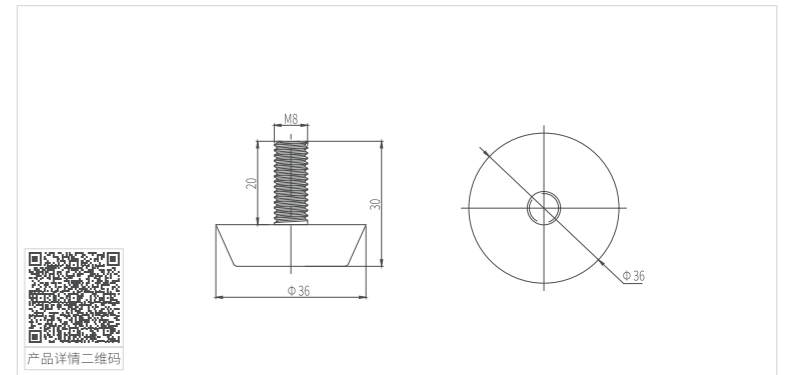

产品详情二维码

MK-XQ-7602 固定可调脚 MK-XQ-7602 Fixed adjustable foot



订货号 Item number	MK-XQ-7602
产品材质 Material	铁+塑料 Iron+plastic
表面处理 Finish	黑色 Black

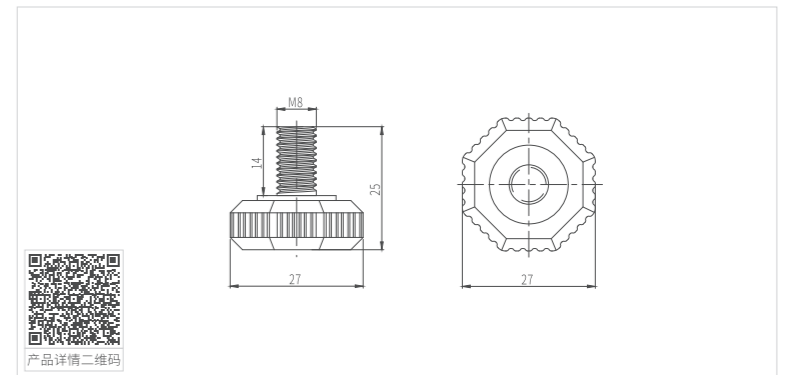

产品详情二维码

MK-XQ-7603 固定可调脚 MK-XQ-7603 Fixed adjustable foot



订货号 Item number	MK-XQ-7603
产品材质 Material	铁+塑料 Iron+plastic
表面处理 Finish	黑色 Black

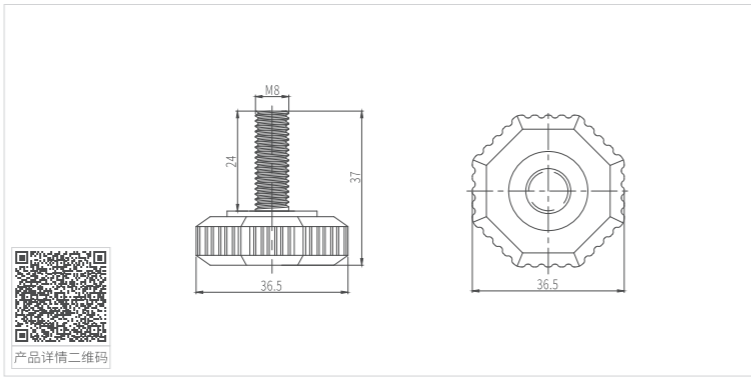

MK-XQ-7704 固定可调脚 MK-XQ-7704 Fixed adjustable foot



订货号 Item number	MK-XQ-7704
产品材质 Material	铁+塑料 Iron+plastic
表面处理 Finish	黑色 Black

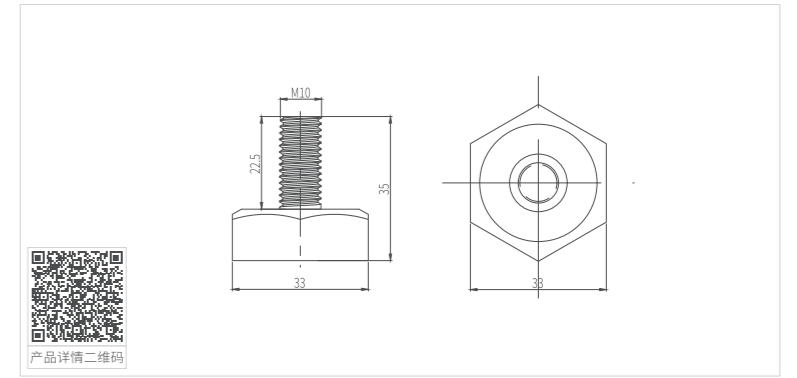

MK-XQ-7702 固定可调脚 MK-XQ-7702 Fixed adjustable foot



订货号 Item number	MK-XQ-7702
产品材质 Material	铁+塑料 Iron+plastic
表面处理 Finish	黑色 Black

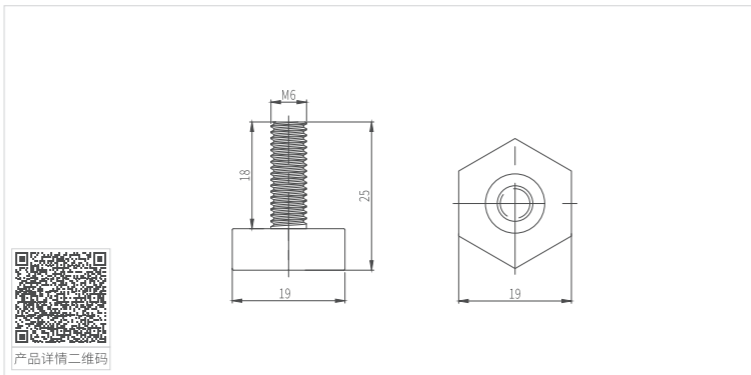

MK-XQ-7801 固定可调脚 MK-XQ-7801 Fixed adjustable foot



订货号 Item number	MK-XQ-7801
产品材质 Material	铁+塑料 Iron+plastic
表面处理 Finish	黑色 Black

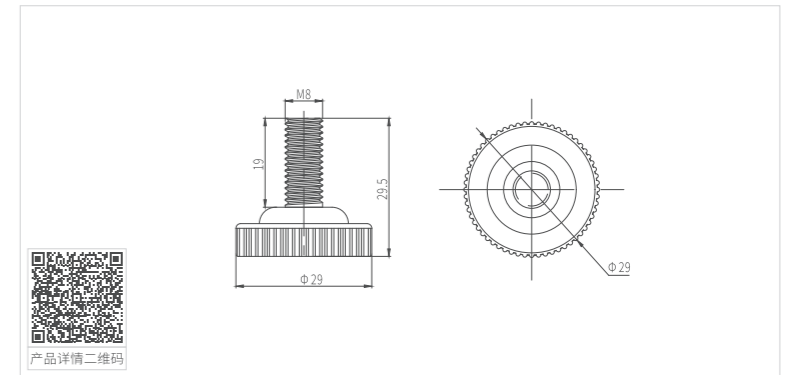

MK-XQ-7703 固定可调脚 MK-XQ-7703 Fixed adjustable foot



订货号 Item number	MK-XQ-7703
产品材质 Material	铁+塑料 Iron+plastic
表面处理 Finish	黑色 Black

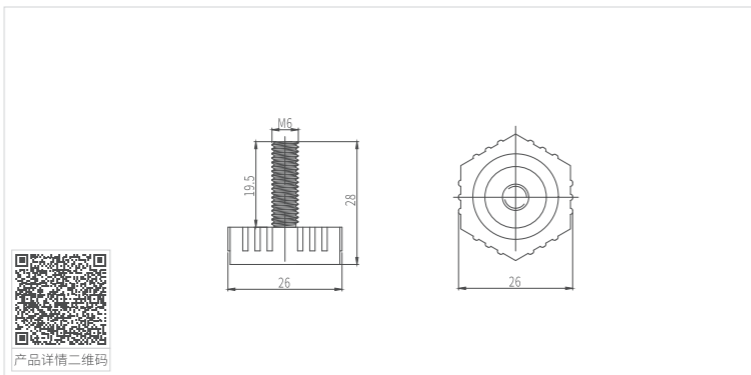

MK-XQ-7802 固定可调脚 MK-XQ-7802 Fixed adjustable foot



订货号 Item number	MK-XQ-7802
产品材质 Material	铁+塑料 Iron+plastic
表面处理 Finish	黑色 Black

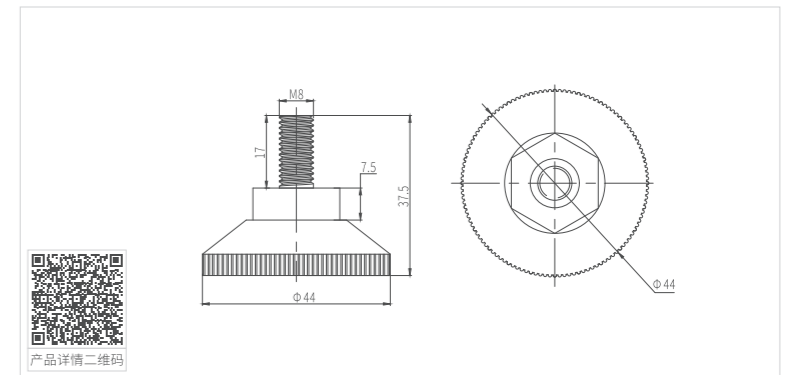

MK-XQ-7803 固定可调脚 MK-XQ-7803 Fixed adjustable foot



订货号 Item number	MK-XQ-7803
产品材质 Material	铁+塑料 Iron+plastic
表面处理 Finish	黑色 Black

产品详情二维码

MK-XQ-7804 固定可调脚 MK-XQ-7804 Fixed adjustable foot



订货号 Item number	MK-XQ-7804
产品材质 Material	铁+塑料 Iron+plastic
表面处理 Finish	黑色 Black

产品详情二维码

MK-XQ-7809 固定可调脚 MK-XQ-7809 Fixed adjustable foot



订货号 Item number	MK-XQ-7809
产品材质 Material	铁+塑料 Iron+plastic
表面处理 Finish	黑色 Black

产品详情二维码

MK-XQ-7902 固定可调脚 MK-XQ-7902 Fixed adjustable foot



订货号 Item number	MK-XQ-7902
产品材质 Material	铁+塑料 Iron+plastic
表面处理 Finish	黑色 Black

产品详情二维码

MK-XQ-7903 固定可调脚 MK-XQ-7903 Fixed adjustable foot



订货号 Item number	MK-XQ-7903
产品材质 Material	铁+塑料 Iron+plastic
表面处理 Finish	黑色 Black

产品详情二维码

MK-XQ-7004 固定可调脚 MK-XQ-7004 Fixed adjustable foot



订货号 Item number	MK-XQ-7004
产品材质 Material	铁+塑料 Iron+plastic
表面处理 Finish	黑色 Black

产品详情二维码

MK-XQ-8001固定可调脚 MK-XQ-8001 Fixed adjustable foot



订货号 Item number	MK-XQ-8001
产品材质 Material	铁+塑料 Iron+plastic
表面处理 Finish	黑色 Black

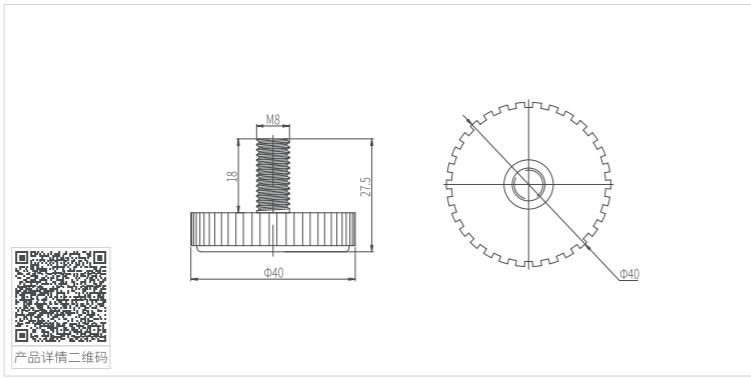

MK-XQ-8004 固定可调脚 MK-XQ-8004 Fixed adjustable foot



订货号 Item number	MK-XQ-8004
产品材质 Material	铁+塑料 Iron+plastic
表面处理 Finish	黑色 Black

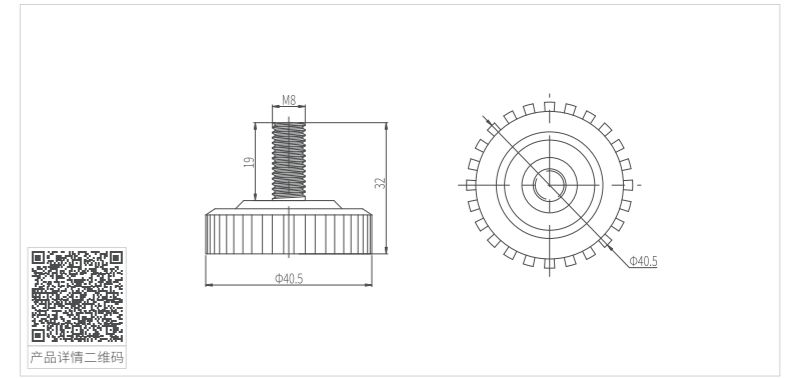

MK-XQ-8002 固定可调脚 MK-XQ-8002 Fixed adjustable foot



订货号 Item number	MK-XQ-8002
产品材质 Material	铁+塑料 Iron+plastic
表面处理 Finish	黑色 Black

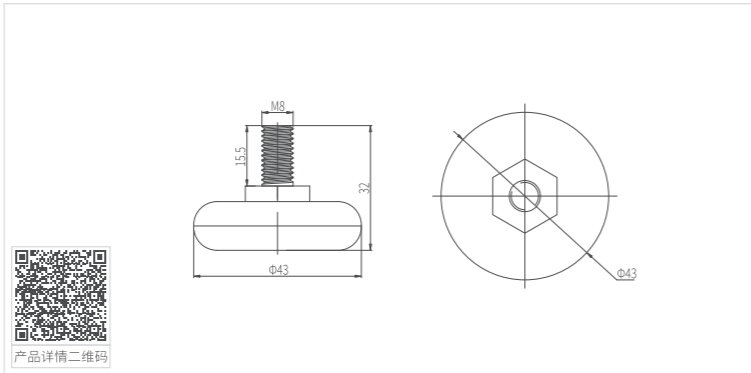

MK-XQ-8301 固定可调脚 MK-XQ-8301 Fixed adjustable foot



订货号 Item number	MK-XQ-8301
产品材质 Material	铁+塑料 Iron+plastic
表面处理 Finish	黑色 Black

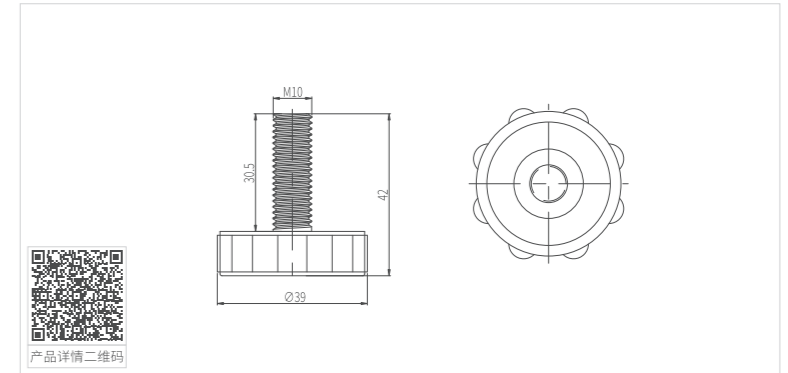

MK-XQ-8003 固定可调脚 MK-XQ-8003 Fixed adjustable foot



订货号 Item number	MK-XQ-8003
产品材质 Material	铁+塑料 Iron+plastic
表面处理 Finish	黑色 Black

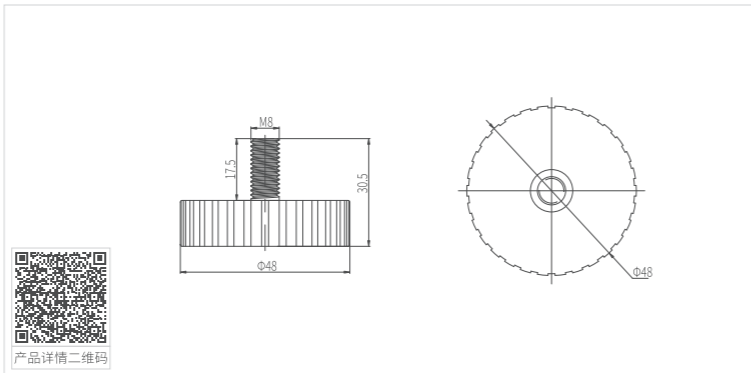

MK-XQ-8401 固定可调脚 MK-XQ-8401 Fixed adjustable foot



订货号 Item number	MK-XQ-8401
产品材质 Material	铁+塑料 Iron+plastic
表面处理 Finish	黑色 Black

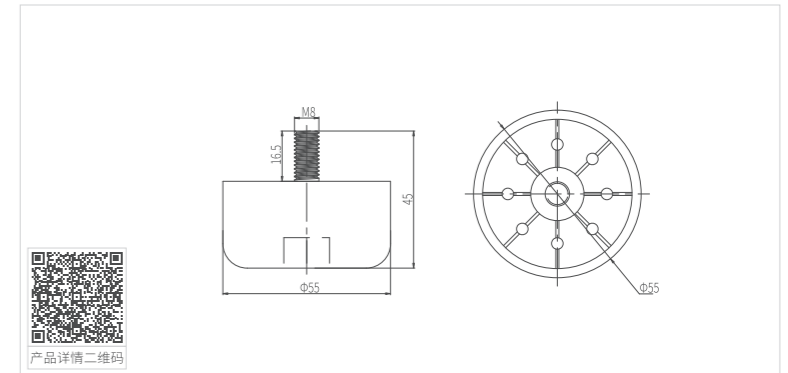

MK-XQ-8501 固定可调脚 MK-XQ-8501 Fixed adjustable foot



订货号 Item number	MK-XQ-8501
产品材质 Material	铁+塑料 Iron+plastic
表面处理 Finish	黑色 Black

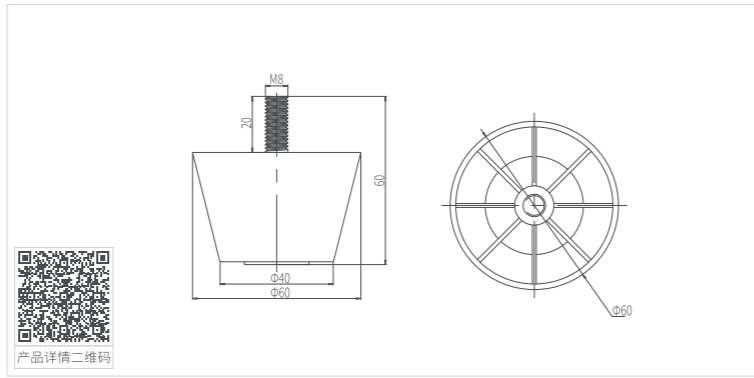

MK-XQ-8102 固定可调脚 MK-XQ-8102 Fixed adjustable foot



订货号 Item number	MK-XQ-8102
产品材质 Material	铁+塑料 Iron+plastic
表面处理 Finish	黑色 Black、白色 White

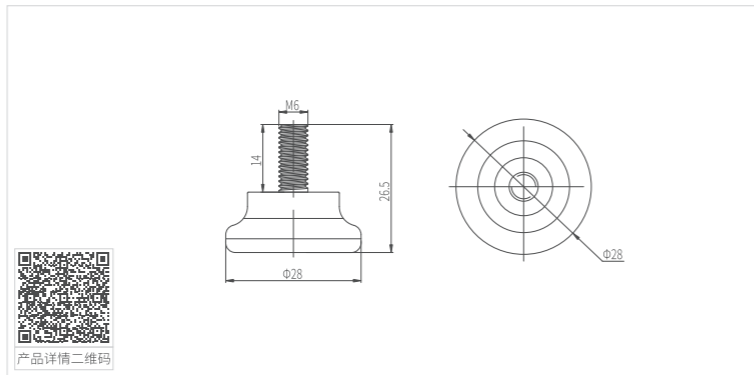

MK-XQ-8104 固定可调脚 MK-XQ-8104 Fixed adjustable foot



订货号 Item number	MK-XQ-8104
产品材质 Material	铁+塑料 Iron+plastic
表面处理 Finish	黑色 Black、白色 White

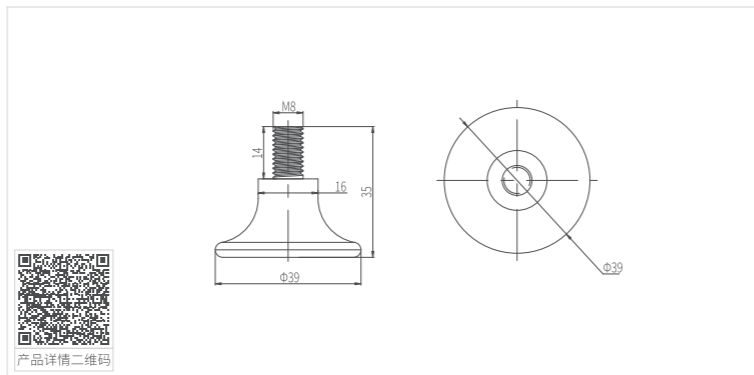

MK-XQ-A8302 固定可调脚 MK-XQ-A8302 Fixed adjustable foot



订货号 Item number	MK-XQ-A8302
产品材质 Material	铁+塑料 Iron+plastic
表面处理 Finish	黑色 Black、白色 White

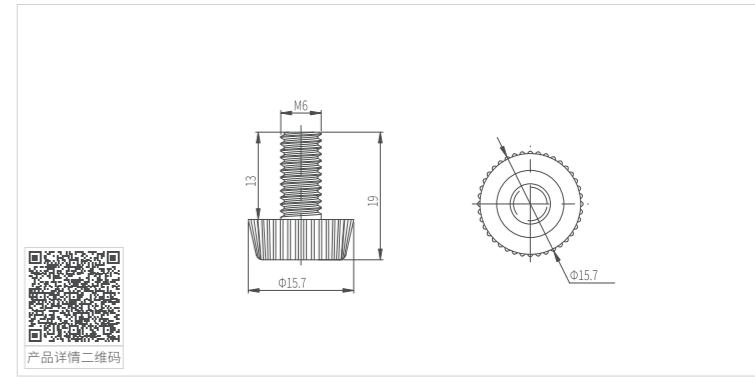

MK-XQ-A8307 固定可调脚 MK-XQ-A8307 Fixed adjustable foot



订货号 Item number	MK-XQ-A8307
产品材质 Material	铁+塑料 Iron+plastic
表面处理 Finish	黑色 Black

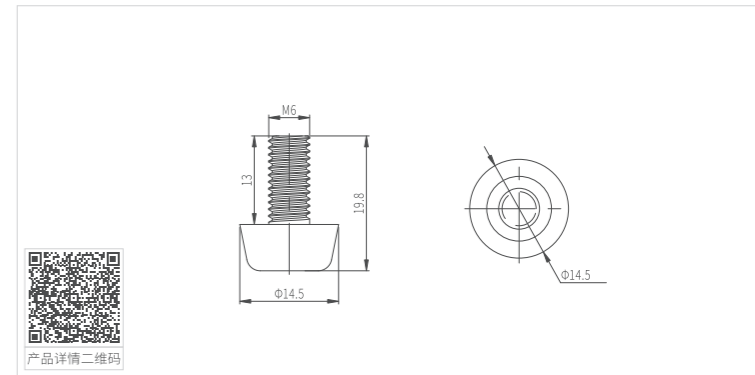

MK-XQ-A8304 固定可调脚 MK-XQ-A8304 Fixed adjustable foot



订货号 Item number	MK-XQ-A8304
产品材质 Material	铁+塑料 Iron+plastic
表面处理 Finish	黑色 Black、白色 White

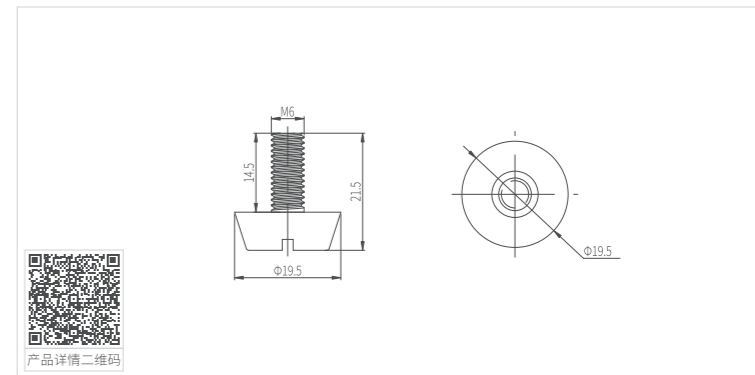



MeiKi明希®

SLIDE SERIES
滑轨系列

SMOOTH AND STEADY
顺畅自如 稳固如山

真材实料, 坚如磐石
不卡顿不晃动, 推拉顺滑
Real stuff, solid as a rock
No stalling, no shaking, push-pull smooth

MK-XL1035 三节钢珠滑轨 MK-XL1035 Three-segment Ball Bearing Slide



全拉出、可拆式三节钢珠滑轨
 滑轨宽度:34.5mm
 载重:25kg
 材质:冷轧钢
 表面处理:电泳、电镀
 Full extension clip on 3 segments ball
 Slide width:34.5mm
 Loading capacity:25kg
 Material:cold rolled steel
 Finish:electrophoresis/electrolysis



产品详情二维码

滑轨安装尺寸 Installation size

滑轨截面 Cross section of slide

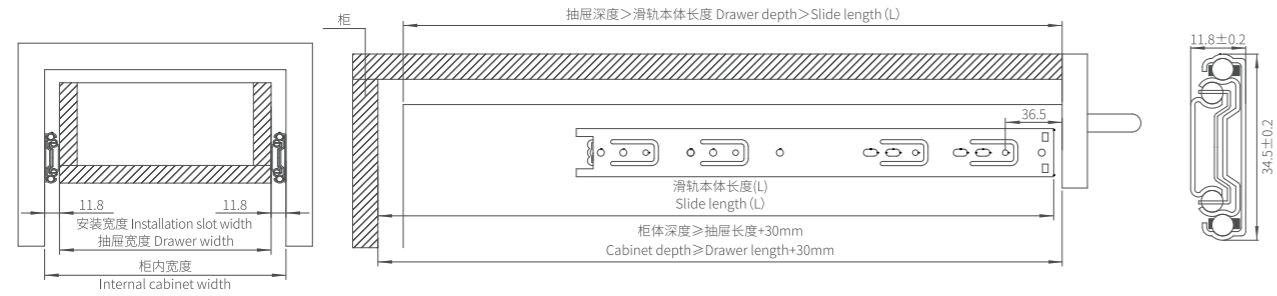

滑轨安装孔尺寸 Hole pattern

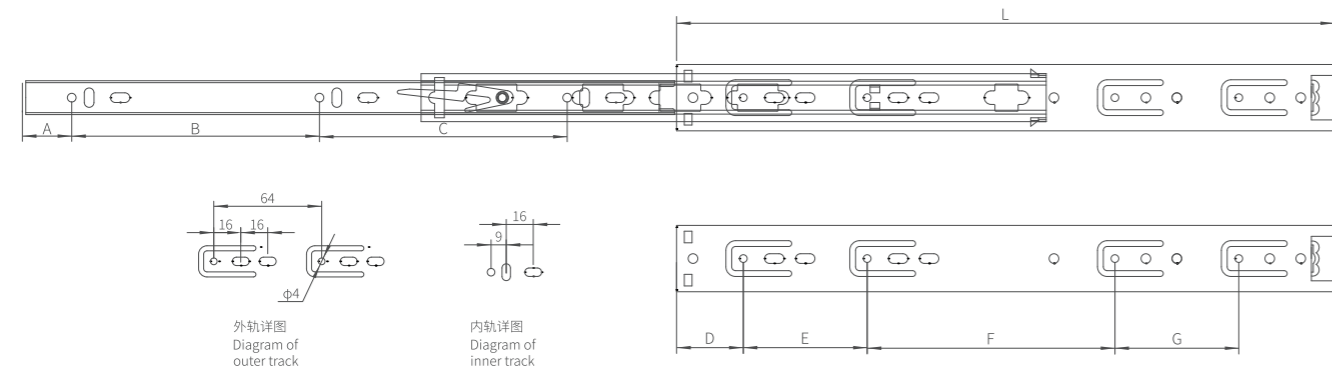

产品型号 Product Type	长度(mm) Length(mm)	A (mm)	B (mm)	C (mm)	D (mm)	E (mm)	F (mm)	G (mm)	L (mm)
MK-XL1035225	225	25.5	153	/	34.5	64	64	/	225
MK-XL1035240	240	25.5	84	84	34.5	64	84	/	240
MK-XL1035290	290	25.5	96	112	34.5	64	128	/	290
MK-XL1035340	340	25.5	128	128	34.5	64	128	64	340
MK-XL1035390	390	25.5	128	160	34.5	64	160	64	390
MK-XL1035440	440	25.5	160	192	34.5	64	224	64	440
MK-XL1035490	490	25.5	160	256	34.5	64	256	64	490

MK-XL4510 三节钢珠滑轨 MK-XL4510 Three-segment Ball Bearing Slide



全拉出、可拆式三节钢珠滑轨
 滑轨宽度:43.8mm
 载重:30kg
 材质:冷轧钢
 表面处理:电泳、电镀
 Full extension clip on three-segment ball bearing slide
 Slide width:43.8mm
 Loading capacity:30kg
 Material:cold rolled steel
 Finish:electrophoresis/electrolysis



产品详情二维码

滑轨安装尺寸 Installation size

滑轨截面 Cross section of slide

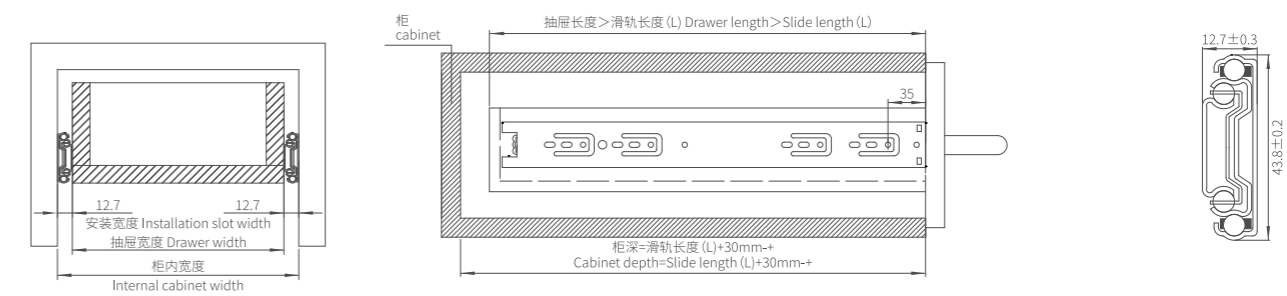

滑轨安装孔尺寸 Hole pattern

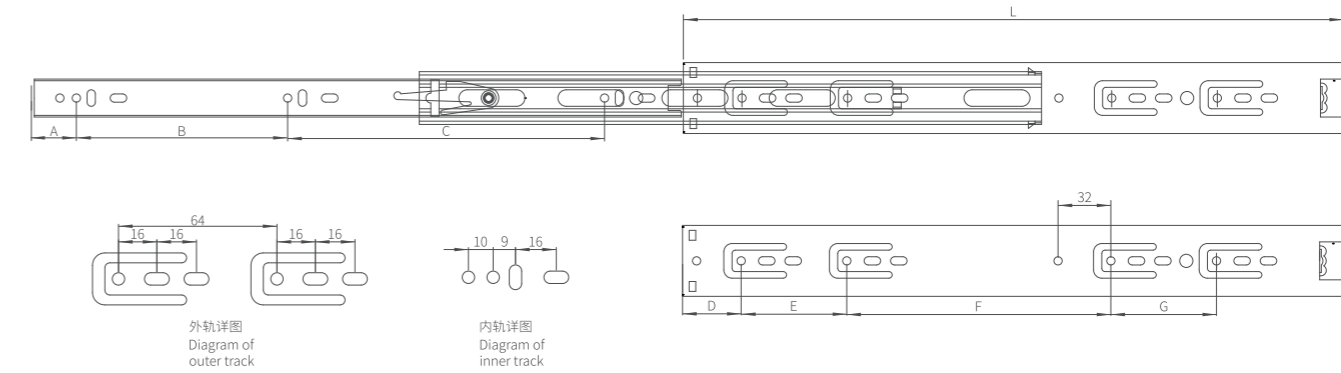

产品型号 Product Type	长度(mm) Length(mm)	A (mm)	B (mm)	C (mm)	D (mm)	E (mm)	F (mm)	G (mm)	L (mm)
MK-XL4510200	200	27	132	/	35.5	96	/	/	200
MK-XL4510240	240	27.5	160	/	35.5	64	79	/	240
MK-XL4510250	250	27	167.5	/	35.5	64	78	/	250
MK-XL4510300	300	27	96	128	35.5	64	128	/	300
MK-XL4510350	350	27	128	128	35.5	64	128	64	350
MK-XL4510400	400	27	128	192	35.5	64	160	64	400
MK-XL4510450	450	27	160	192	35.5	64	224	64	450
MK-XL4510500	500	27	192	224	35.5	64	256	64	500

MK-RXFT4510 反弹三节钢珠滑轨 MK-RXFT4510 Push-to-open Three-segment Ball Bearing Slide



全拉出、可拆式反弹三节钢珠滑轨
 滑轨宽度:45.2mm
 载重:30kg
 材质:冷轧钢
 表面处理:电泳、电镀
 Full extension clip on push-to-open three-segment ball bearing slide
 Slide width:45.2mm
 Loading capacity:30kg
 Material:cold rolled steel
 Finish:electrophoresis/electrolysis



滑轨安装尺寸 Installation size

滑轨截面 Cross section of slide

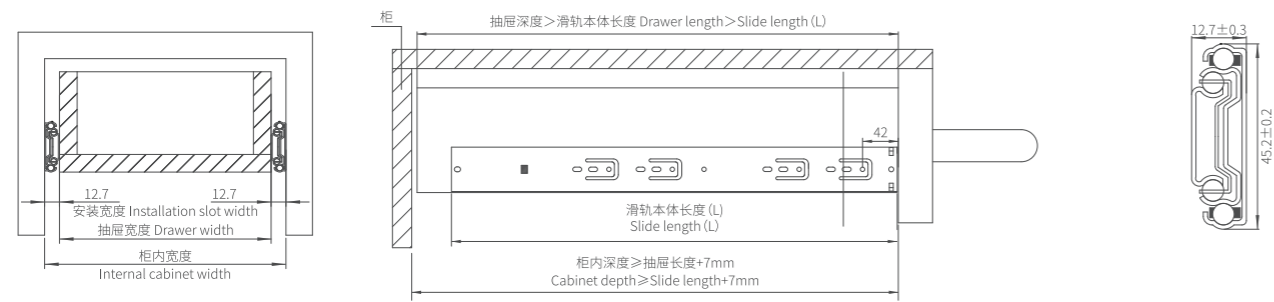

滑轨安装孔尺寸 Hole pattern

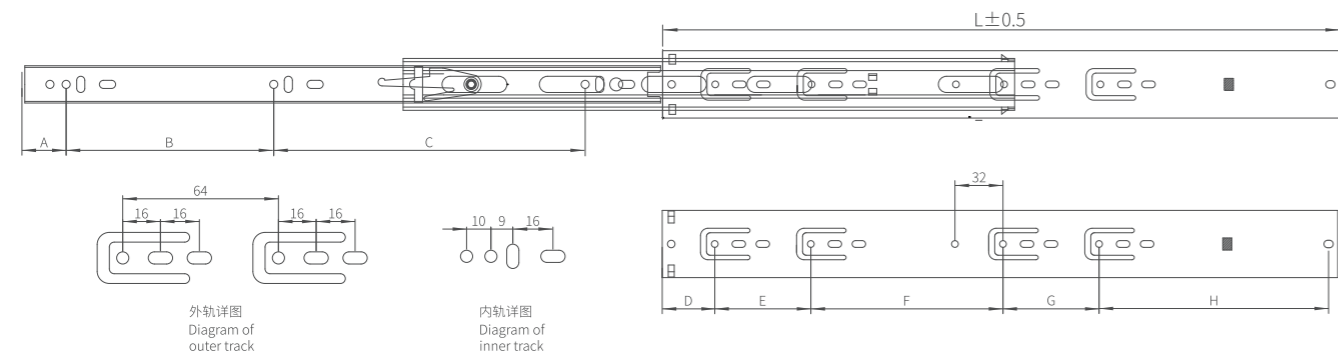

产品型号 Product Type	长度(mm) Length(mm)	A (mm)	B (mm)	C (mm)	D (mm)	E (mm)	F (mm)	G (mm)	H (mm)	L (mm)
MK-RXFT4510250	250	26	160	/	35	64	/	/	145	250
MK-RXFT4510300	300	26	96	128	35	64	/	/	195	300
MK-RXFT4510350	350	26	128	128	35	64	96	/	149	350
MK-RXFT4510400	400	26	160	160	35	64	96	64	135	400
MK-RXFT4510450	450	26	160	192	35	64	128	64	153	450
MK-RXFT4510500	500	26	192	224	35	64	160	64	171	500

MK-RXZN4510 阻尼三节钢珠滑轨 MK-RXZN4510 Full Extension Removable Damper Three-segment Ball Bearing Slide



全拉出、可拆式阻尼三节钢珠滑轨
 滑轨宽度:45.2mm
 载重:30kg
 材质:冷轧钢
 表面处理:电泳、电镀
 Full extension clip on damper three-segment ball bearing slide
 Slide width:45.2mm
 Loading capacity:30kg
 Material:cold rolled steel
 Finish:electrophoresis/electrolysis



滑轨安装尺寸 Installation size

滑轨截面 Cross section of slide

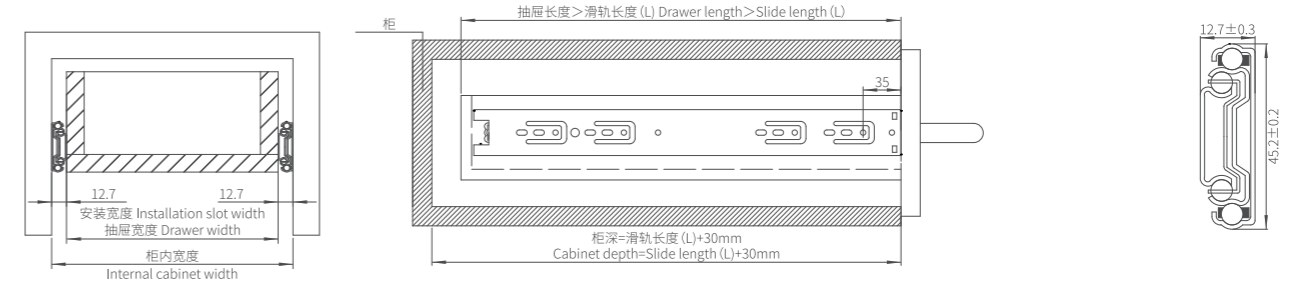

滑轨安装孔尺寸 Hole pattern

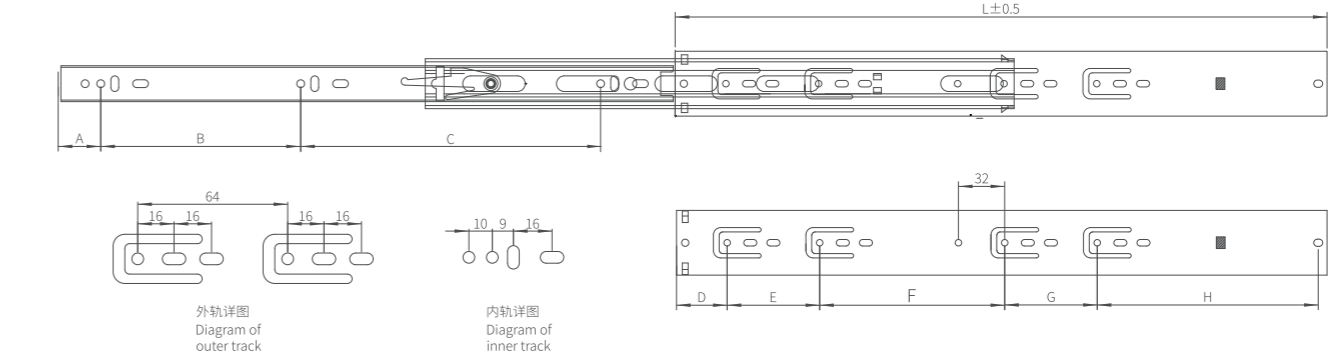

产品型号 Product Type	长度(mm) Length(mm)	A (mm)	B (mm)	C (mm)	D (mm)	E (mm)	F (mm)	G (mm)	H (mm)	L (mm)
MK-RXZN4510250	250	26	160	/	35	64	/	/	145	250
MK-RXZN4510300	300	26	96	128	35	64	/	/	195	300
MK-RXZN4510350	350	26	128	128	35	64	96	/	149	350
MK-RXZN4510400	400	26	160	160	35	64	96	64	135	400
MK-RXZN4510450	450	26	160	192	35	64	128	64	153	450
MK-RXZN4510500	500	26	192	224	35	64	160	64	171	500

MK-RXHC216B 两节缓冲隐藏滑轨(带插销) MK-RXHC216B Two-segment Soft-closing Concealed Slide (with fixing pin)

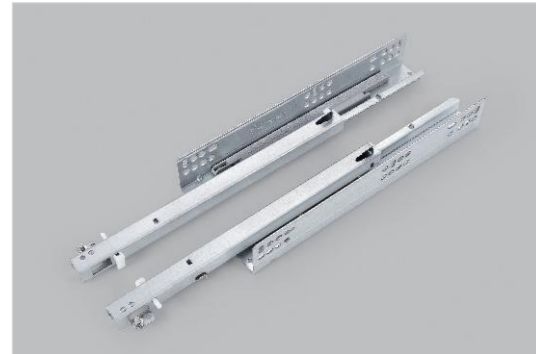

二节隐藏式缓冲滑轨(带插销)
适用板厚:16mm
载重:30kg
材质:镀锌板

Two-segment Soft-closing Concealed Slide (with fixing pin)
Panel thickness: 16mm
Loading capacity: 30kg
Material: Galvanized steel



MK-RXFT216B 两节反弹隐藏滑轨(带插销) MK-RXFT216B Two-segment Push-open Concealed Slide (with fixing pin)



二节隐藏式反弹滑轨(带插销)
适用板厚:16mm
载重:30kg
材质:镀锌板

Two-segment Push-open Concealed Slide (with fixing pin)
Panel thickness: 16mm
Loading capacity: 30kg
Material: Galvanized steel



滑轨安装尺寸 Installation size

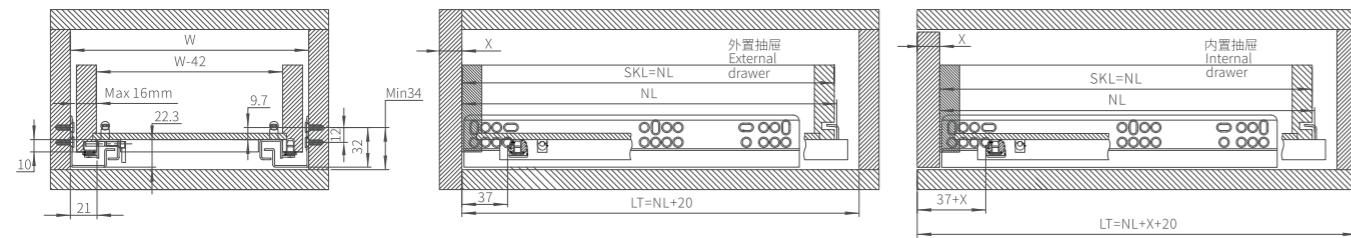

W=柜内宽度 SKL=抽屉长度 NL=滑轨标称长度 AL=滑轨实际长度 W=Internal cabinet width SKL=Drawer length NL=Nominal length of slide
LT=柜体内部深度 X=面板厚度 DP=钻孔深度 LT=Internal cabinet depth X=Thickness of the front panel DP=Drilling depth

滑轨安装尺寸 Installation size

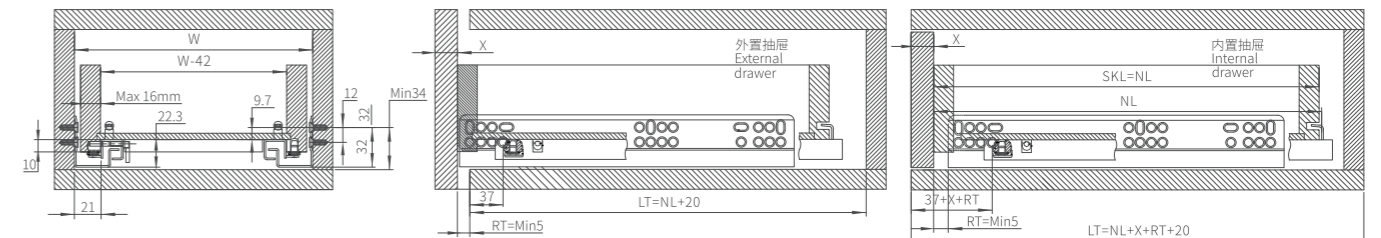

W=柜内宽度 SKL=抽屉长度 NL=滑轨标称长度 AL=滑轨实际长度 W=Internal cabinet width SKL=Drawer length NL=Nominal length of slide
LT=柜体内部深度 X=面板厚度 RT=反弹间隙 DP=钻孔深度 LT=Internal cabinet depth X=Thickness of the front panel DP=Drilling depth
RT=Round gap

滑轨安装孔尺寸 Hole pattern

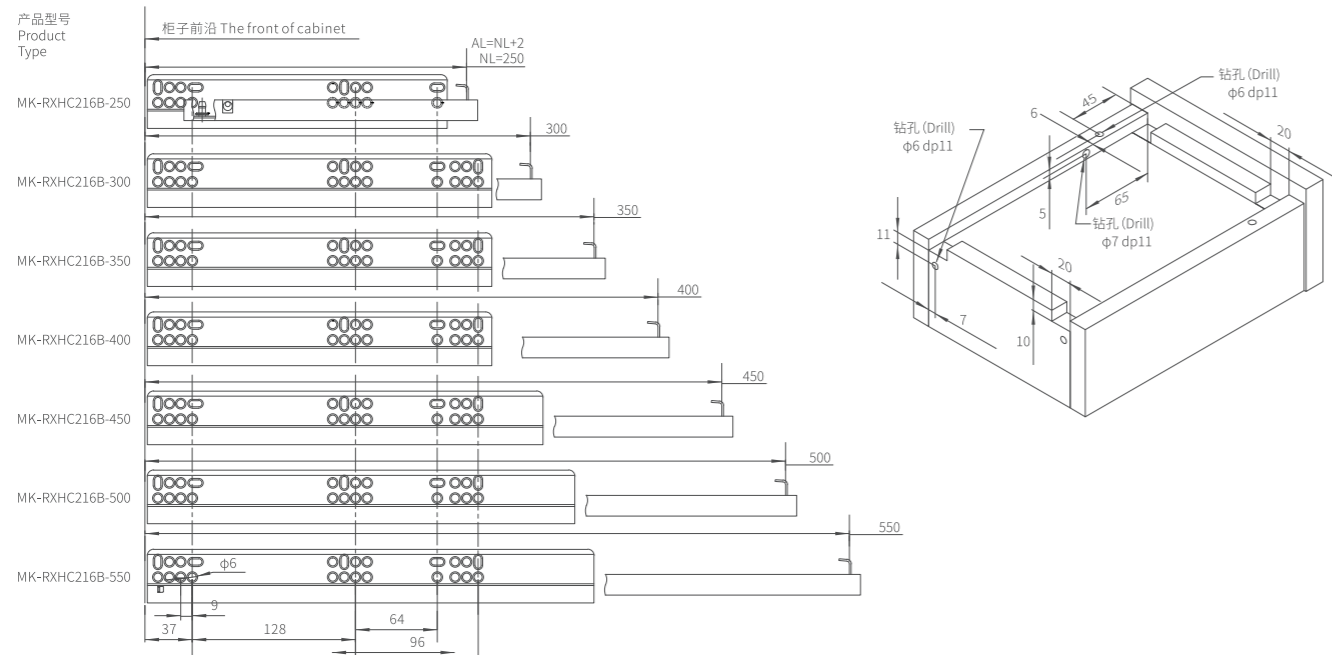

滑轨安装孔尺寸 Hole pattern

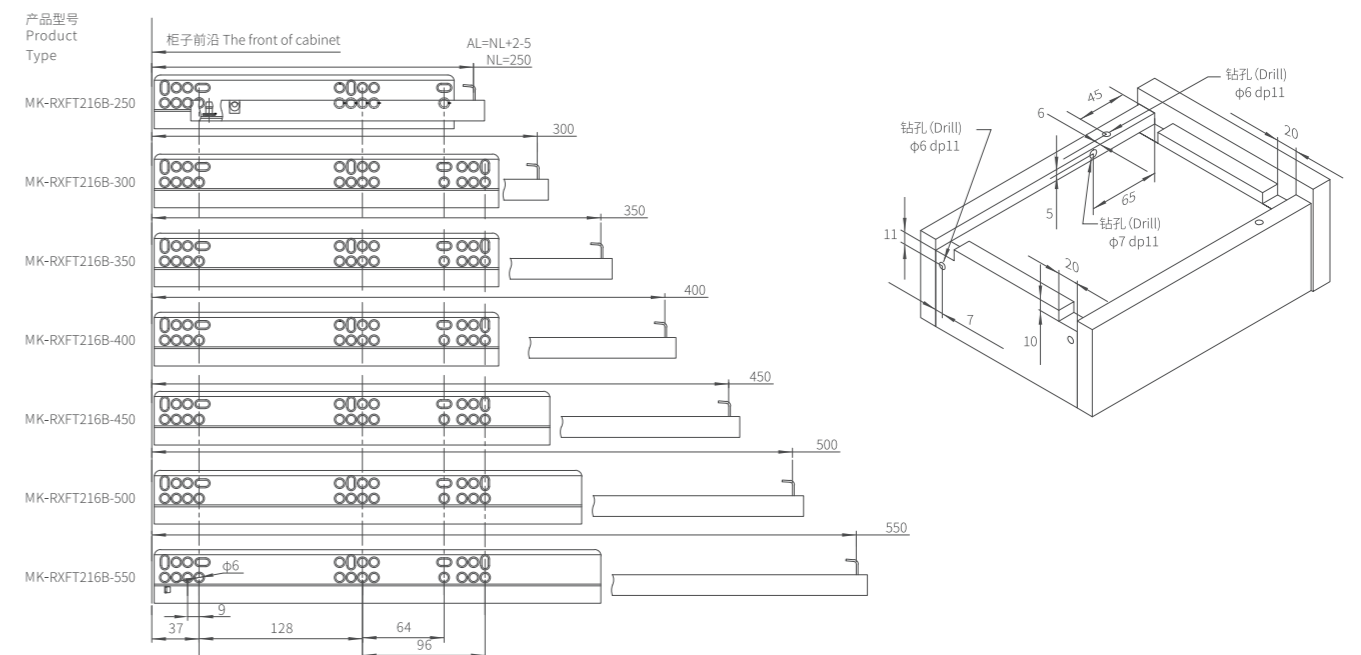

MK-RXHC318 三节缓冲隐藏滑轨 (三维调节) MK-RXHC318 Three-segment Soft-closing Concealed Slide (3D adjustment)



三节隐藏式缓冲滑轨 (三维调节)
 适用板厚: 18mm
 载重: 30kg
 材质: 镀锌板

Three-segment Soft-closing Concealed Slide (3D adjustment)
 Panel thickness: 18mm
 Loading capacity: 30kg
 Material: Galvanized steel



滑轨安装尺寸 Installation size

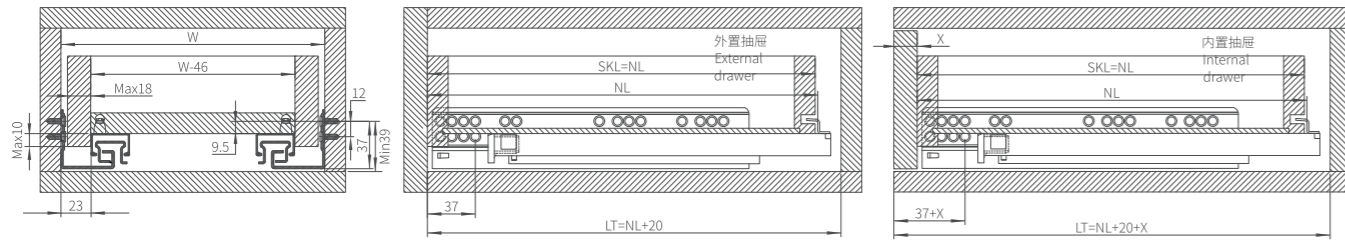

W=柜内宽度 SKL=抽屉长度 NL=滑轨标称长度 AL=滑轨实际长度 W=Internal cabinet width SKL=Drawer length NL=Nominal length of slide
 LT=柜体内部深度 X=面板厚度 DP=钻孔深度 LT=Actual length of slide LT=Internal cabinet depth X=Thickness of the front panel DP=Drilling depth

滑轨安装孔尺寸 Hole pattern

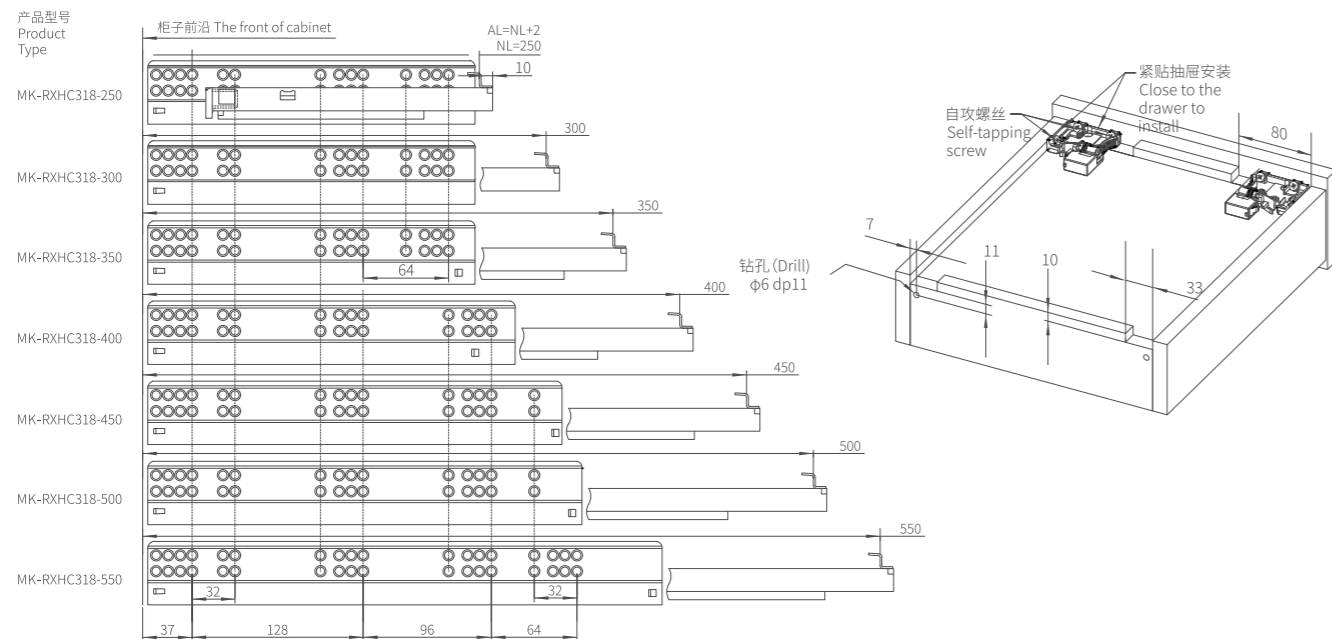

MIK-RXFT318 三节反弹隐藏滑轨 (三维调节) MIK-RXFT318 Three-segment Push-open Concealed Slide (3D adjustment)

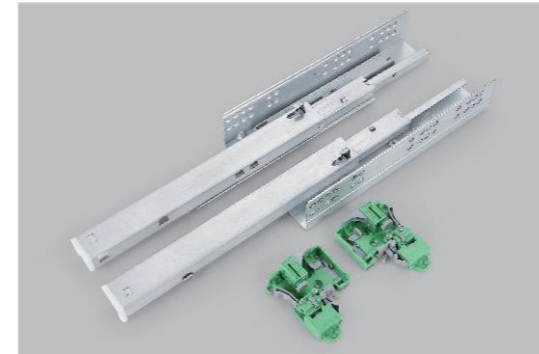

三节隐藏式反弹滑轨 (三维调节)
 适用板厚: 18mm
 载重: 30kg
 材质: 镀锌板

Three-segment Push-open Concealed Slide (3D adjustment)
 Panel thickness: 18mm
 Loading capacity: 30kg
 Material: Galvanized steel



滑轨安装尺寸 Installation size

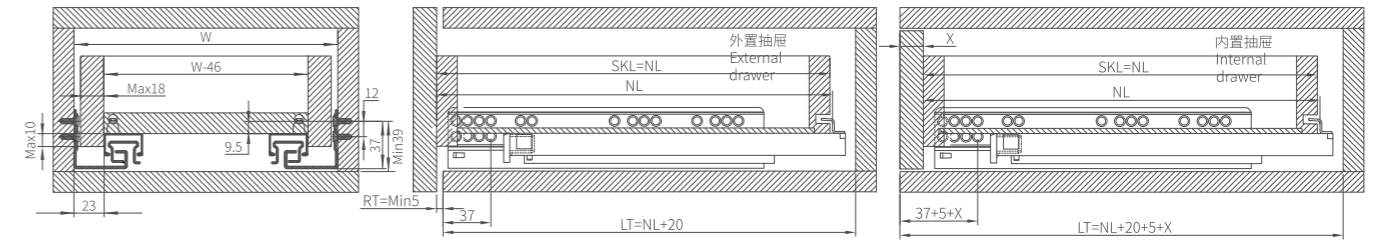

W=柜内宽度 SKL=抽屉长度 NL=滑轨标称长度 AL=滑轨实际长度 W=Internal cabinet width SKL=Drawer length NL=Nominal length of slide
 LT=柜体内部深度 X=面板厚度 RT=反弹间隙 DP=钻孔深度 LT=Actual length of slide LT=Internal cabinet depth X=Thickness of the front panel DP=Drilling depth

滑轨安装孔尺寸 Hole pattern

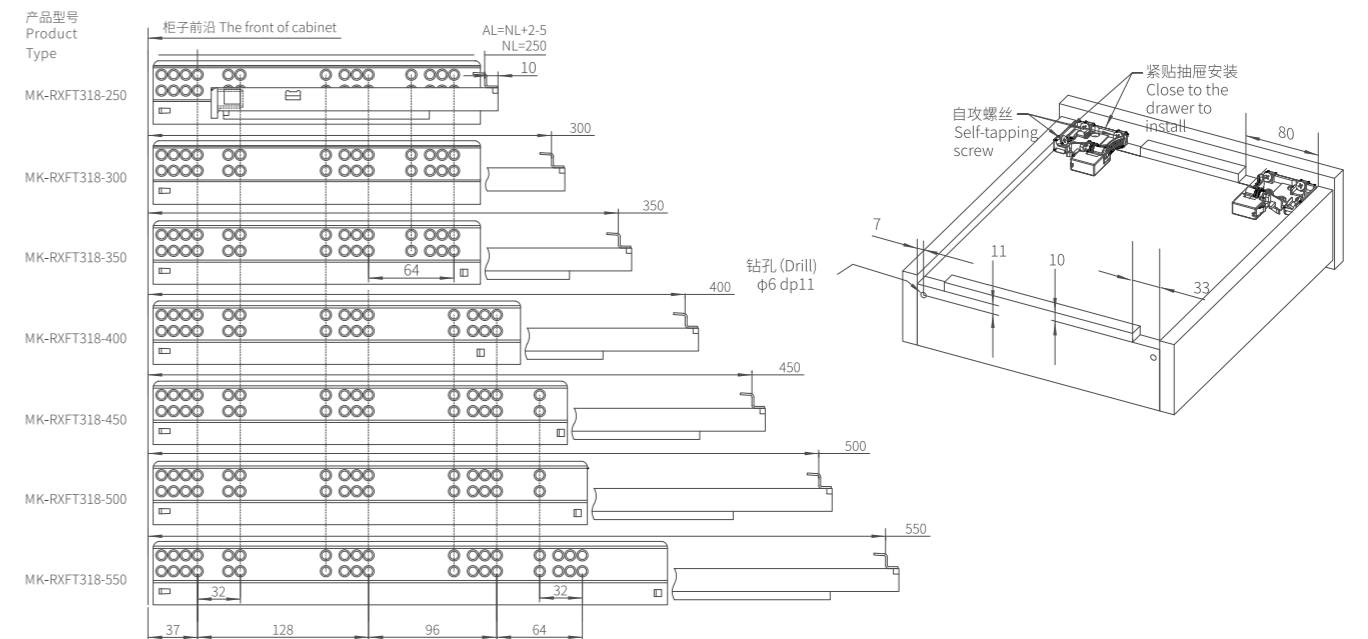



MeiKi明希®

METALBOX RUNNERS SERIES
骑马抽系列

SLIM BEAUTY DEXTEROUS PUSH AND PULL LIGHT
纤美灵巧 推拉轻盈

负重推拉不费劲, 久用依然平稳
全展视野, 抽屉空间一览无余
Load-bearing pushing and pulling is not strenuous,
and it is still stable for a long time
Full view, drawer space unobstructed



纤薄而不失稳固
于方寸间彰显生活美学
Thin yet firm
Show the aesthetics of life in the square inch

MK-TM908TB 隐藏式、全拉式滑轨 (低抽、中抽、高抽) MK-TM908TB Concealed full-extension slide (low drawer, middle drawer and high drawer)

隐藏式; 三节 (全展), 导向性滑动
内置变速阻尼, 滑轨寿命长
确保滑轨运动顺滑轻柔关闭
动态可承重35kg, 静态承重45kg

Concealed; three segments (full-extension); guided slip
Variable speed damper prolongs service life of slide
Ensure the smooth movement and gentle close of track
The dynamic load is 35kg and the static load is 45kg



MK-TM908TB-84 低抽

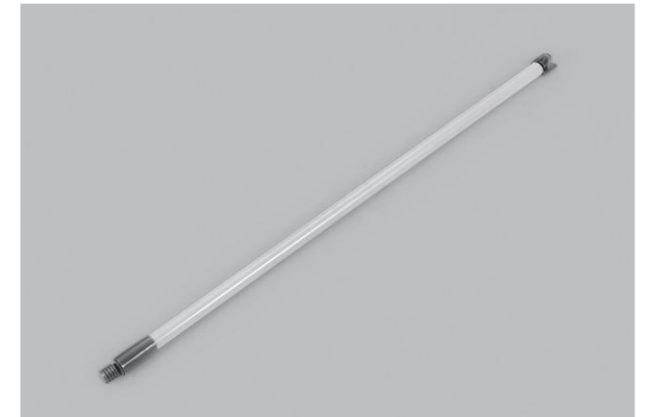

圆杆



MK-TM908TB-135 中抽



方杆



MK-TM908TB-199 高抽



产品详情二维码

MK-TM908TB 隐藏式、全拉式滑轨 (低抽、中抽、高抽) MK-TM908TB Concealed full-extension slide (low drawer,middle drawer and high drawer)

产品配件图 Diagram of accessories

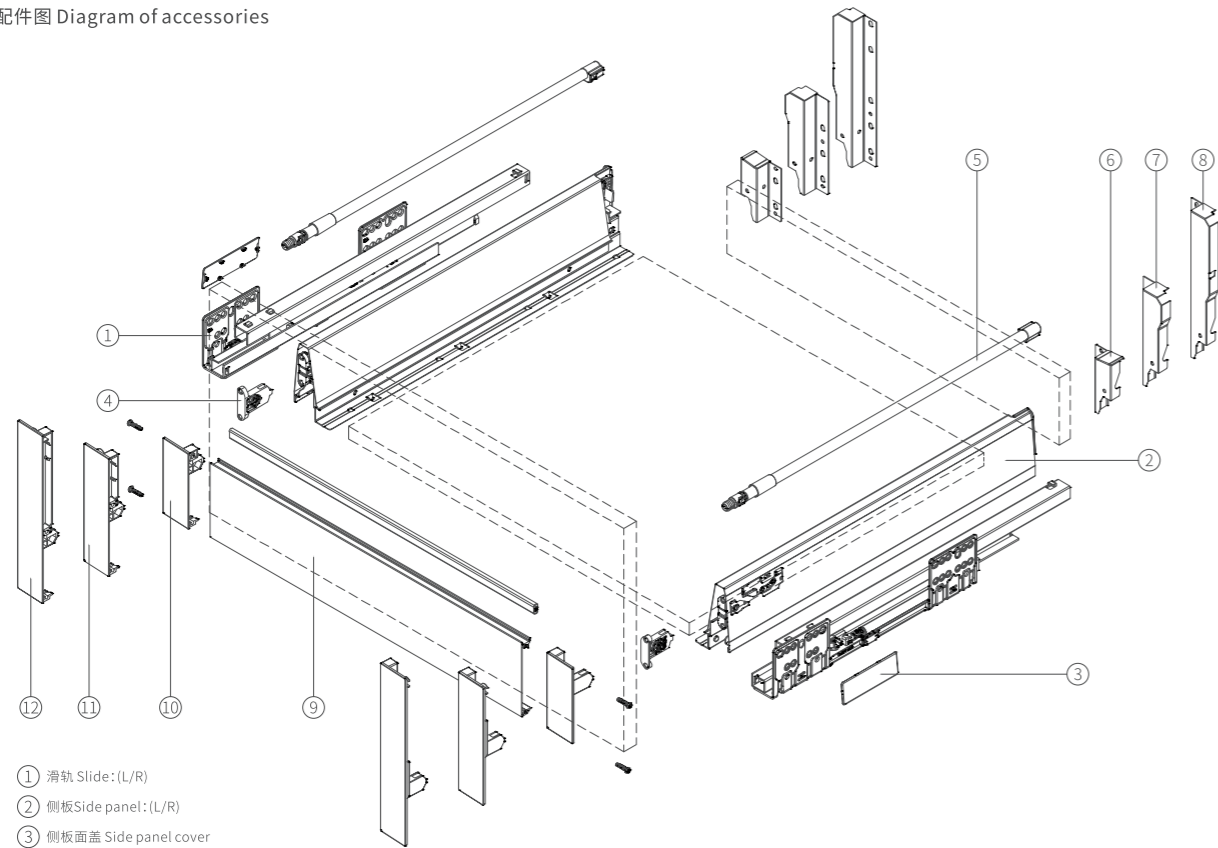

- ① 滑轨 Slide: (L/R)
- ② 侧板 Side panel: (L/R)
- ③ 侧板面盖 Side panel cover
- ④ 前接码 Front connector
- ⑤ 拉杆 Pull rod
- ⑥ BL84 背板件 Back board accessories
- ⑦ BL135 背板件 Back board accessories
- ⑧ BL199 背板件 Back board accessories
- ⑨ 内抽铝面板 Aluminium panel
- ⑩ 84mm 内抽面板扣 Drawer buckle
- ⑪ 135mm 内抽面板扣 Drawer buckle
- ⑫ 199mm 内抽面板扣 Drawer buckle

产品型号 Product Type	基本长度(mm) Basic length(mm)	内部可用长度(mm) Internal available length(mm)	抽屉最小安装长度(mm) Minimum mounting length of drawer(mm)
MK-TM908TB-270	270	244	280
MK-TM908TB-300	300	274	310
MK-TM908TB-350	350	324	360
MK-TM908TB-400	400	374	410
MK-TM908TB-450	450	424	460
MK-TM908TB-500	500	474	510
MK-TM908TB-550	550	524	560

滑轨安装尺寸 Installation size of slide

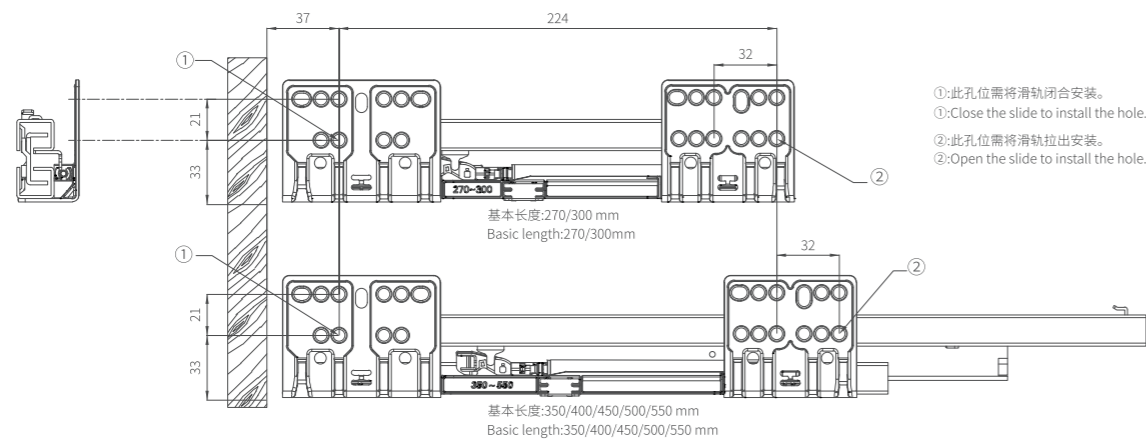

MK-TM908TB 隐藏式、全拉式滑轨 (低抽、中抽、高抽) MK-TM908TB Concealed full-extension slide (low drawer,middle drawer and high drawer)

MK-TM908TB-84 产品安装尺寸 Installation size

箱体所需空间
Space required in the drawer

前接码面板安装尺寸
Front connector board

FA:面板重叠部分
FA:The overlapping part of board

面板钻孔尺寸
Board drilling

孔径 Bore diameter	φ2*12	φ10*12
所用螺丝 Screw type	木牙螺丝 Wood screw	膨胀螺丝 Expansion screw
螺丝尺寸 Screw size	M4*17	M10*10

背板安装尺寸
Back board

MK-TM908TB-135 产品安装尺寸 Installation size

箱体所需空间
Space required in the drawer

前接码面板安装尺寸
Front connector board

FA:面板重叠部分
FA:The overlapping part of board

面板钻孔尺寸
Board drilling

孔径 Bore diameter	φ2*12	φ10*12
所用螺丝 Screw type	木牙螺丝 Wood screw	膨胀螺丝 Expansion screw
螺丝尺寸 Screw size	M4*17	M10*10

背板安装尺寸
Back board

MK-TM908TB-199 产品安装尺寸 Installation size

箱体所需空间
Space required in the drawer

前接码面板安装尺寸
Front connector board

FA:面板重叠部分
FA:The overlapping part of board

面板钻孔尺寸
Board drilling

孔径 Bore diameter	φ2*12	φ10*12
所用螺丝 Screw type	木牙螺丝 Wood screw	膨胀螺丝 Expansion screw
螺丝尺寸 Screw size	M4*17	M10*10

背板安装尺寸
Back board

MK-TM908TB 隐藏式、全拉式滑轨 (低抽、中抽、高抽) MK-TM908TB Concealed full-extension slide (low drawer, middle drawer and high drawer)

木板开料尺寸(技术重点)
Board size(Technical focus)

须用16mm板
LW:柜体净宽
背板高度(见“注释”)
Height of back board(see “note”)
背板长度=LW-87±0.5
Length of back board=LW-87±0.5
底板宽度=LW-75±0.5
Width of base board=LW-75±0.5
底板长度=基本长度-24mm
Length of base board=Basic length-24mm

	TB84	TB135	TB199
背板高度 Height of back board	84	135	199

内抽横拉杆长度=LW-71±0.5
Length of inner pull rod=LW-71±0.5
内抽铝面板长=LW-87±0.5
Length of inner aluminum panel=LW-87±0.5
前接码安装方向
Installation of front connector

背板的安装
Installation of back board

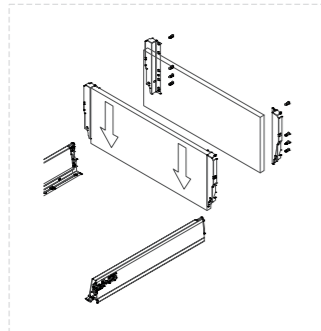

底板的安装
Installation of base board

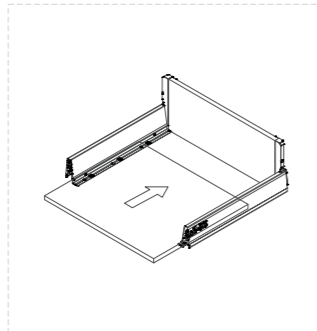

面板的安装
Installation of front board

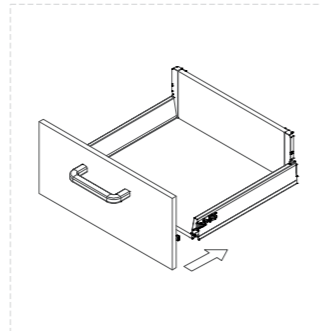

底板上螺丝
Screw on base board

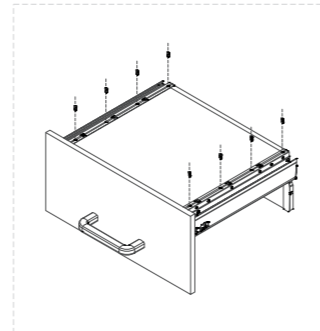

扣入背板件
Install back board accessories

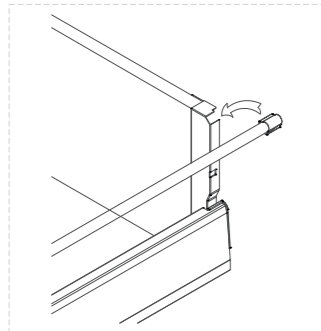

扣入面板卡件
Install front board accessories

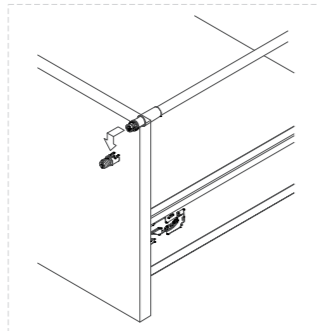

套好拉杆套
Put on pull rod sleeve

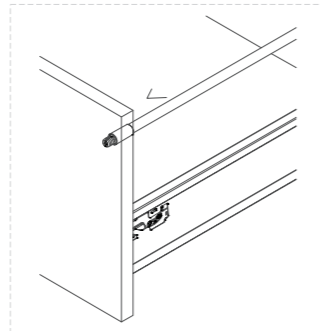

安装完成
Done

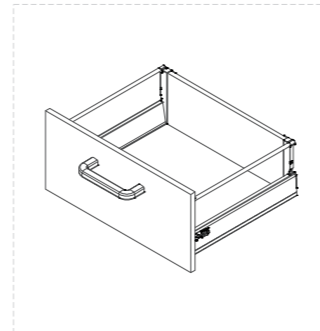

抽屉的安装及拆卸
Assembly and disassembly of drawer

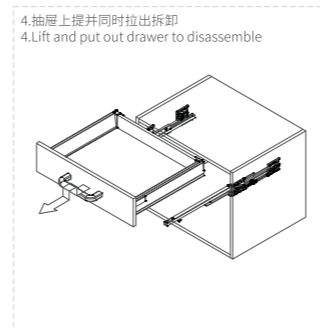
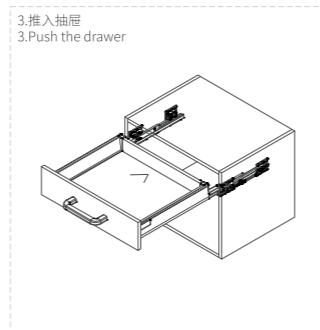
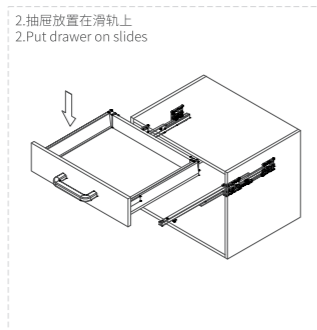
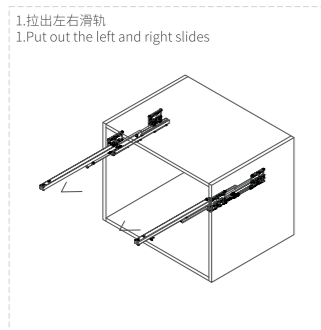

MK-TM908TB 隐藏式、全拉式滑轨 (低抽、中抽、高抽) MK-TM908TB Concealed full-extension slide (low drawer, middle drawer and high drawer)

面板的安装
Installation of front board

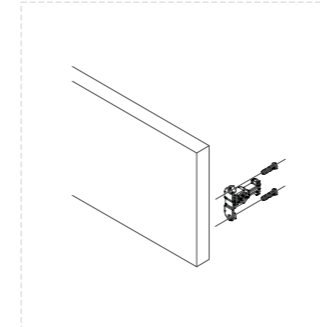

面板的拆卸
Disassembly of front board

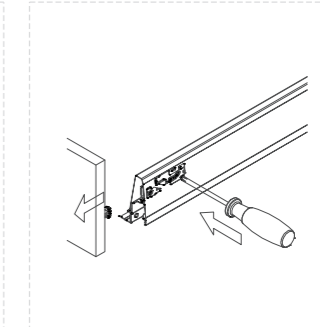
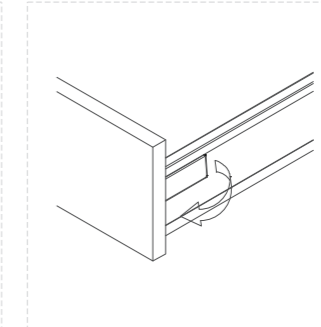
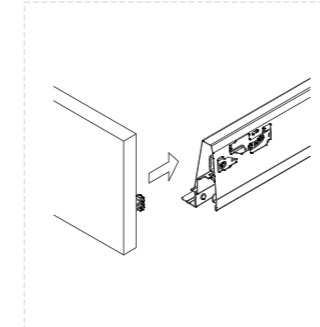

面板高度调节: ±2mm
Height adjustment: ±2mm

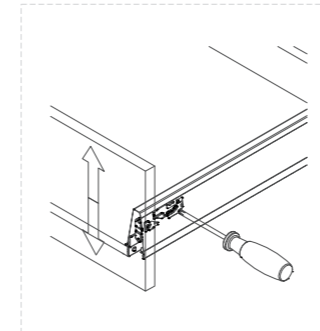

面板侧面调节: 向右1mm
Side adjustment: towards the right 1mm

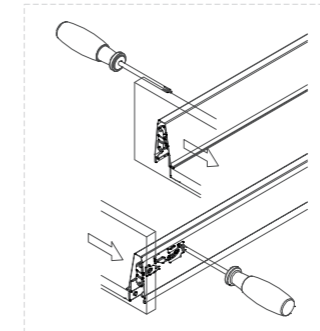

面板侧面调节: 向左1mm
Side adjustment: towards the left 1mm

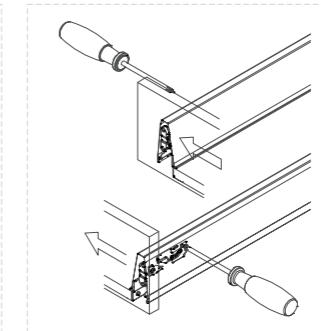

面板斜度调节
Slant angle adjustment

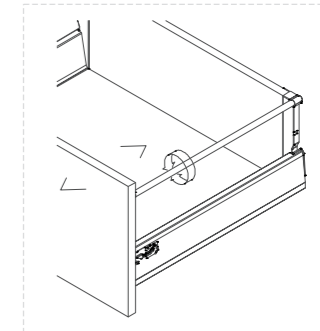

内抽面板的安装
Assembly of interior drawer board

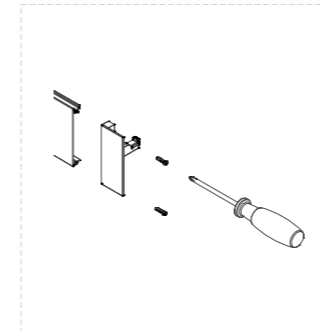

内抽面板的拆卸
Disassembly of interior drawer board

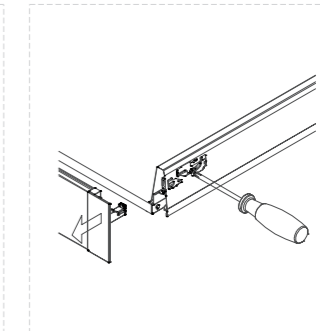
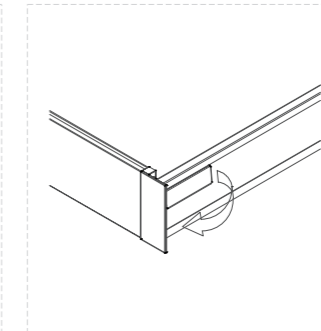
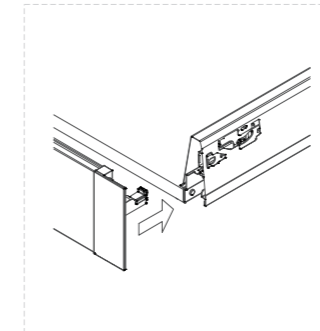

内抽面板高度调节: ±2mm
Height adjustment: ±2mm

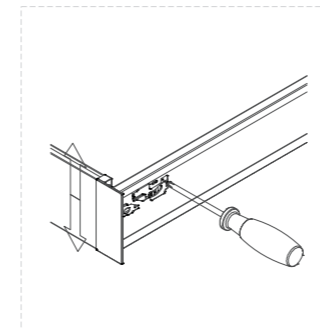

内抽面板斜度调节
Inclination adjustment

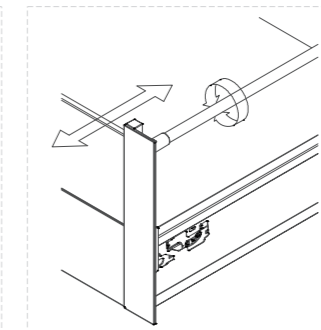
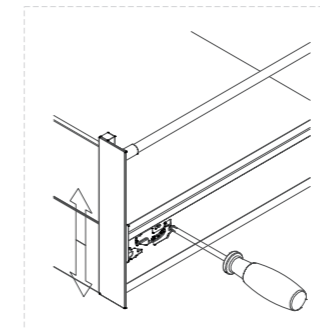

内低抽面板上下所需间隙
Space above and below the board

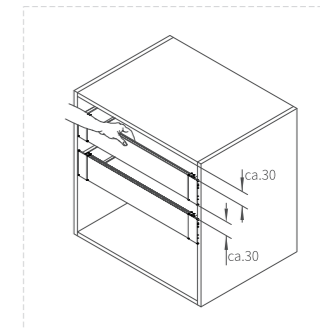



MeiKi明希®

HINGE SERIES
铰链系列

SAFE QUIET LIFE COMFORTABLE
安全静音 生活舒心

阻尼缓冲, 轻柔开合
广角开启, 取物更从容
Damping buffer, gentle opening and closing
Wide Angle open, more leisurely fetch

轻型天地铰链2.0 Light-weight Hinge

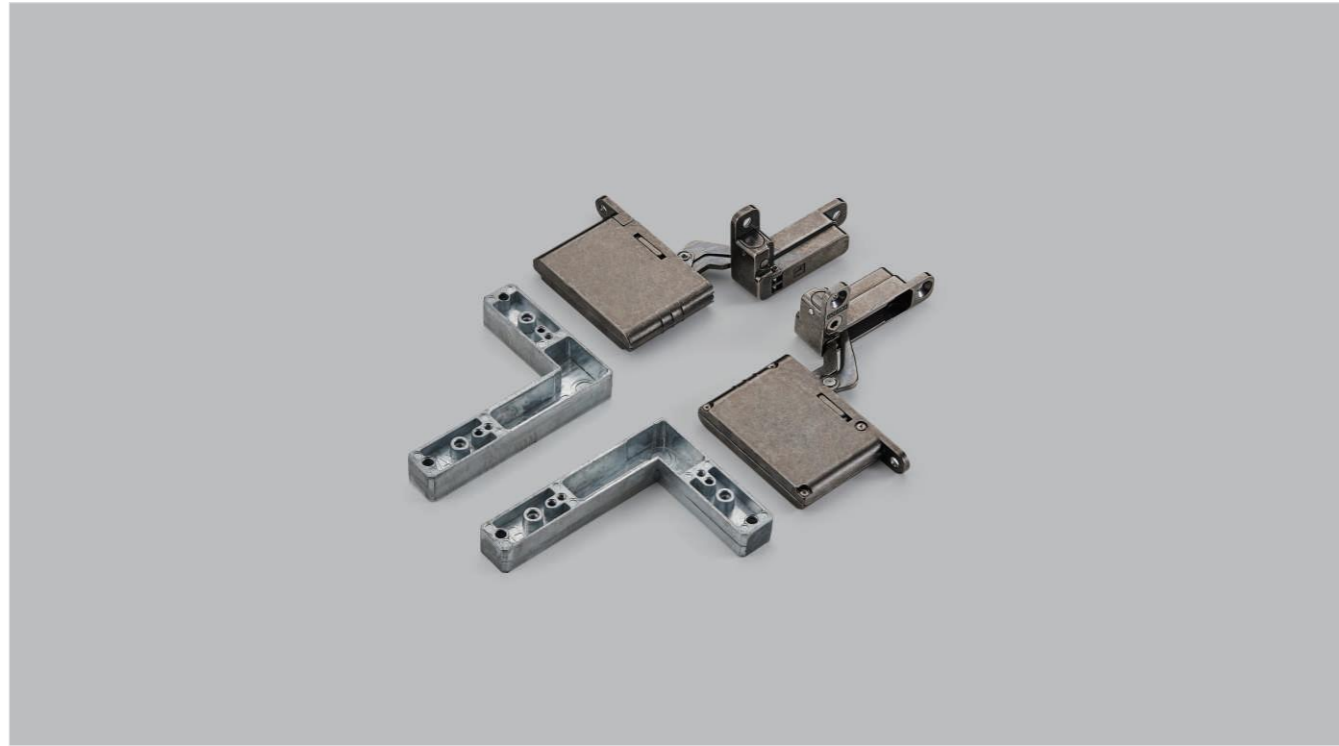

开启角度:105°
 最大负重:25KG
 门最大尺寸:高2700mm、宽600mm
 主要材料:冷轧钢
 表面处理:枪黑、镍
 配件:铰链R、铰链L、
 角码R(选配)、角码L(选配)

Opening Angle: 105°
 Max Load:25KG
 Max Size of the door: Height 2700mm、Width 600mm
 Main material: Cold rolled steel
 Finish: Gun Black, Nickel plating
 Accessories: Hinge R, hinge L,
 BracketR(option), Bracket L(option)



订货号 Item number : MK-KY-TDJ2.0-25KG

A向 A Towards

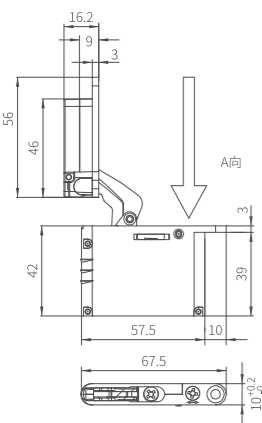

B向 B Towards

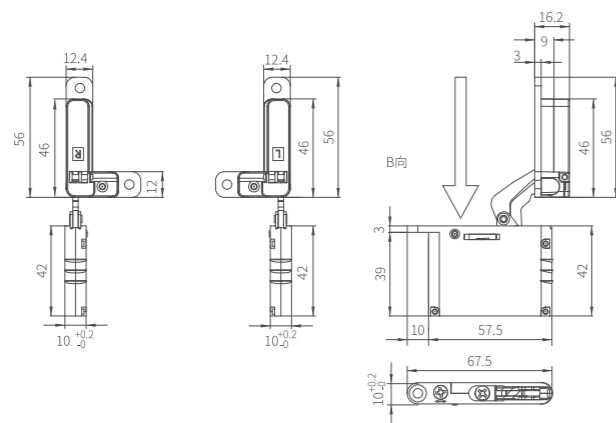

角码 Bracket

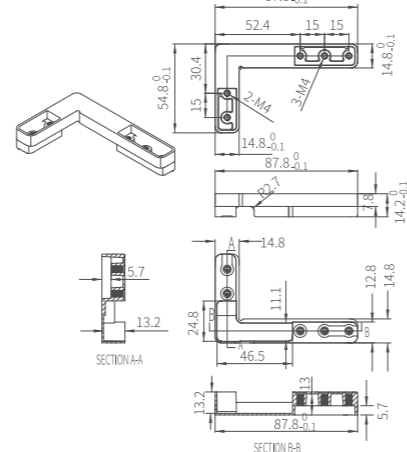

轻型天地铰链(2.0)安装说明书 Light-weight Hinge(2.0) Installation Manual

一、配件分类 Accessories Category

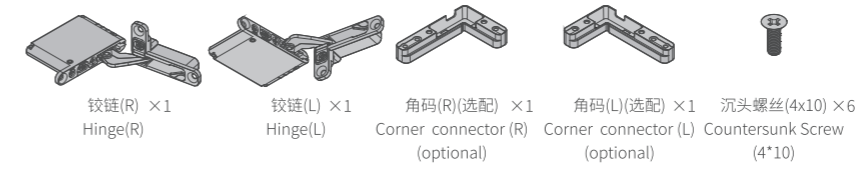

二、门板与柜体参数 Door panel and cabinet parameters

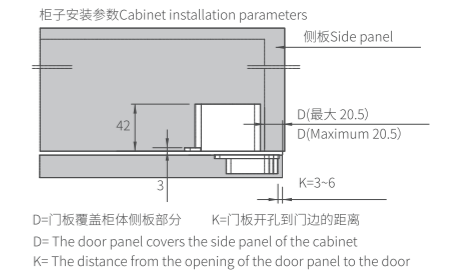

三、安装尺寸(A=B) Mounting dimension

1、柜体开孔尺寸图 Cabinet opening size drawing 单位 Unit :mm

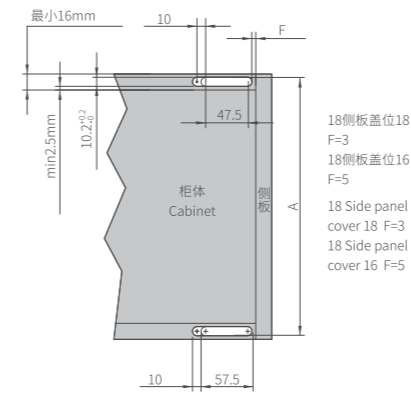

2、木门和铝门框开孔尺寸图 Dimensions of wood door and aluminum door frame openings 单位 Unit :mm

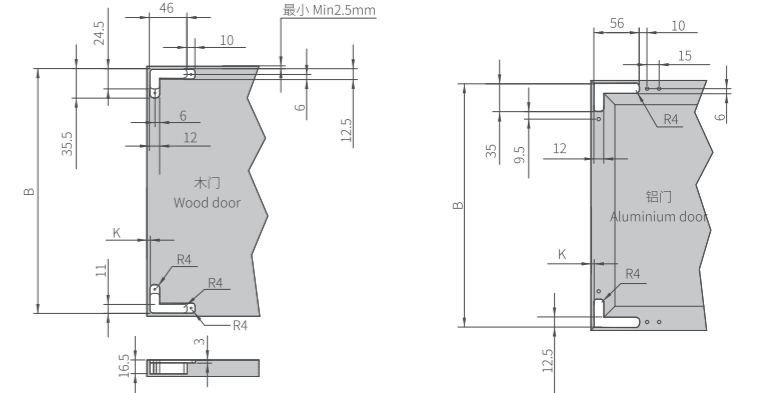

四、安装步骤 Installation Steps

1、铰链安装在门板上 The hinges are mounted on the door panel 2、门板与柜体安装(A=B) Door panel and cabinet installation

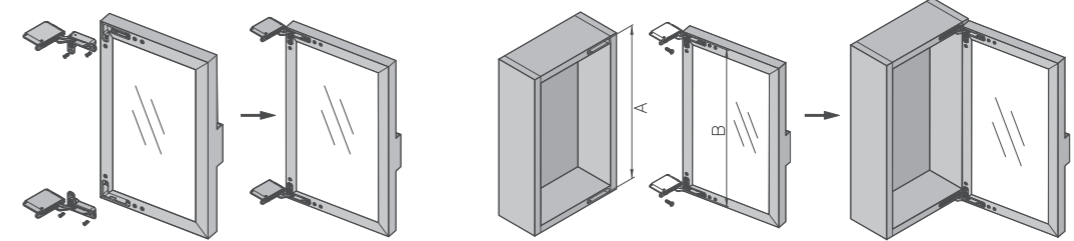

五、三维调节与快慢调节 3-D adjustment, fast and slow adjustment

1、左右方向调节 Left and right adjustment 2、闭合力度调节 Closing force adjustment 3、前后方向调节 Front and rear direction adjustment 4、上下方向调节 Up and down adjustment

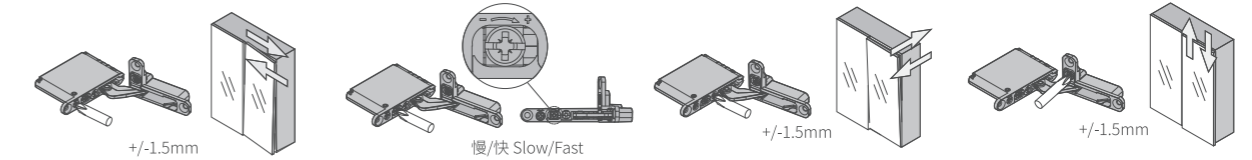

六、柜子倾斜自检 Cabinet tilt self test

1、柜子左右倾斜自检 Cabinet tilt left and right self test 2、柜子前后倾斜自检 Cabinet tilt back and forth self test

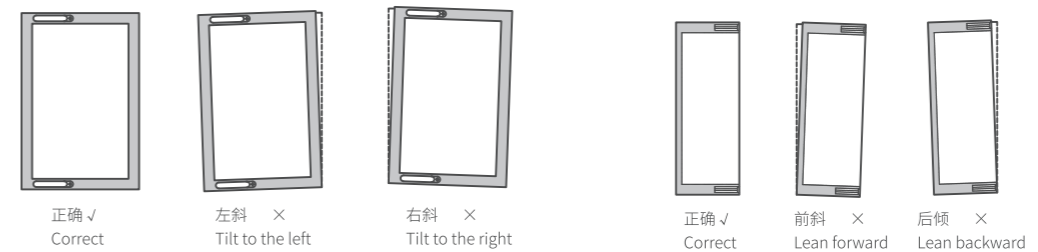

重型天地铰链2.0 Heavy-weght hinge



开启角度:103°
 最大负重:35KG
 门最大尺寸:高2700mm、宽600mm
 主要材料:冷轧钢
 表面处理:枪黑、镍
 配件:铰链R、铰链L、
 角码R(选配)、角码L(选配)

Opening Angle:103°
 Max Load:35KG
 Max Size of the door: Height 2700mm、Width 600 mm
 Main material: Cold rolled steel
 Finish: Gun Black、Nickel plating
 Accessories: Hinge R、hinge L、
 BracketR(option)、Bracket L(option)



订货号 Item number : MK-KY-TDJ2.0-30KG

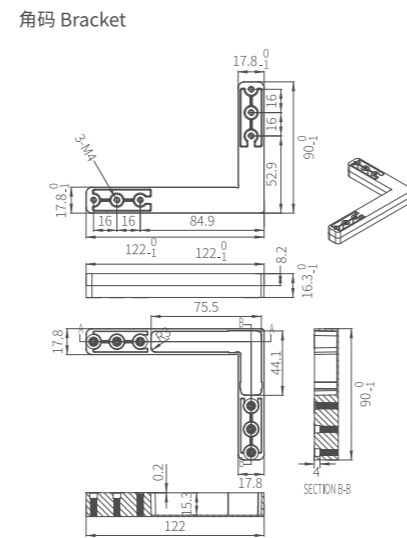
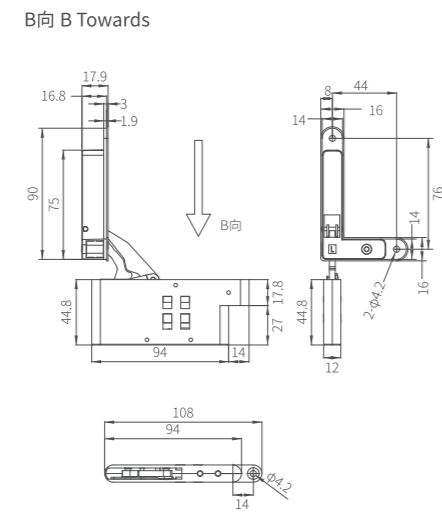
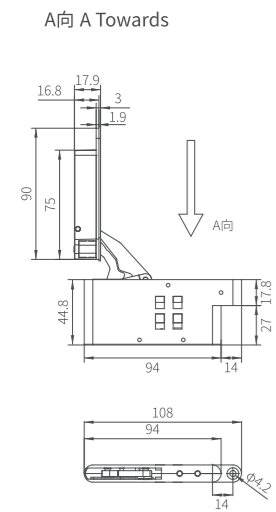

重型天地铰链(2.0)安装说明书 Heavy-weght hinge(2.0) Installation Manual

一、技术说明 Technical Description

重型天地铰链,内置集成阻尼,小巧紧凑,安装于柜体的顶板和底板。①可三维调节;②最大负重35公斤;③门最大尺寸:高3米×宽0.65米;④最大开启角度105°。

二、配件分类 Accessories Category

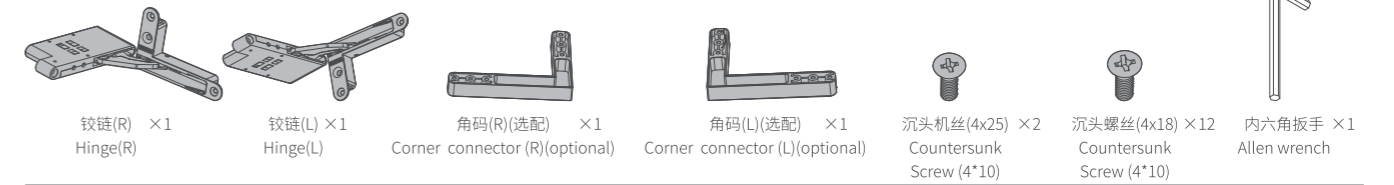

三、安装步骤 Installation Steps

1、铰链安装在门板上 The hinges are mounted on the door panel

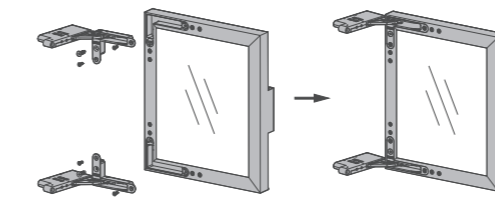

2、门板与柜体安装 Door panel and cabinet installation

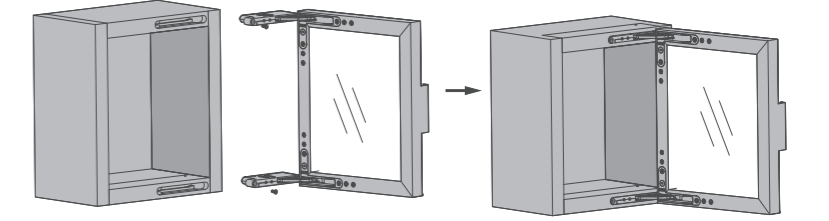

四、三维调节 3-D adjustment

1、左右调节 Left and right adjustment

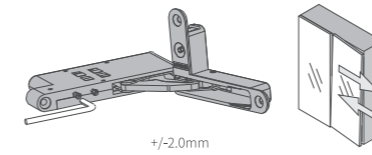

2、前后方向调节 Front and rear direction adjustment

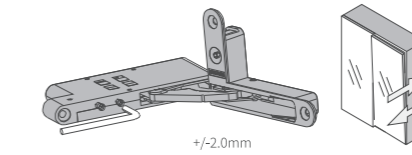

3、上下方向调节 Up and down adjustment

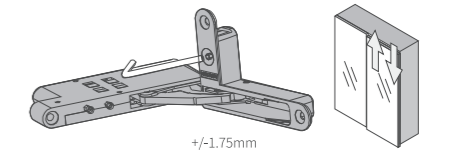

五、铝材参数 Aluminum Profile parameter

3、铝型材截面 Section 单位 Unit : mm

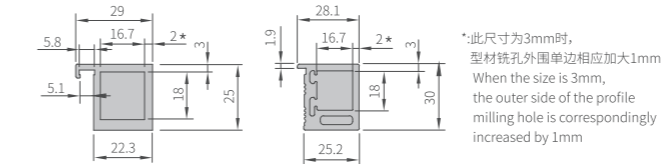

2、横梁型材开孔尺寸 Crossbeam profile opening size 单位 Unit : mm

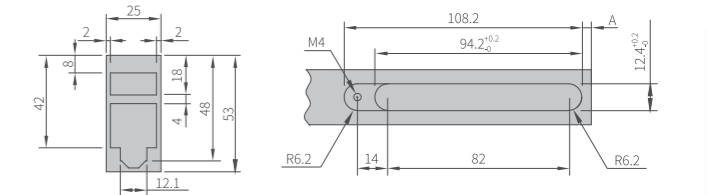

六、开孔尺寸 Hole Size

标准安装模式 Standard installation mode 单位 Unit : mm

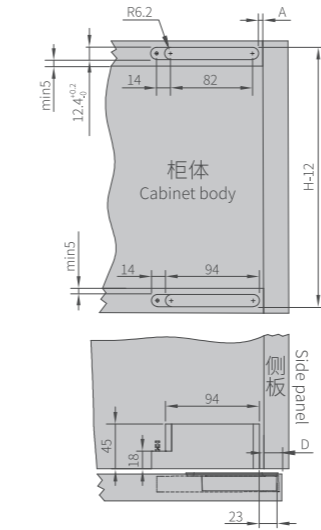

带套安装模式 Installation mode with sleeve 单位 Unit : mm

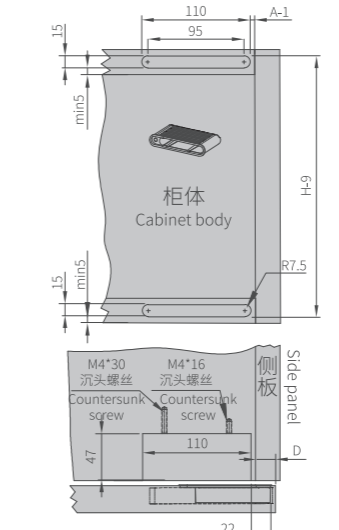

开门所需侧面距离 Side distance to open door

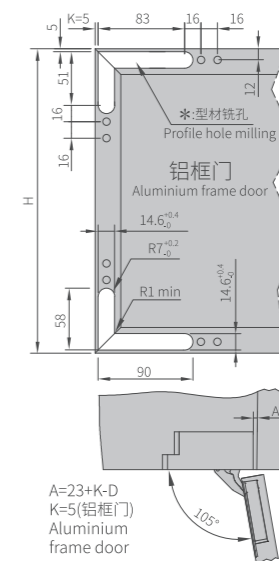

	K=	4	5	6	7
T=26	L=	0	0	0	0
T=28	L=	0.2	0.2	0.2	0.2
T=30	L=	0.5	0.5	0.5	0.5
T=32	L=	1.0	1.0	1.0	1.0
T=34	L=	1.8	1.8	1.8	1.8
T=36	L=	2.8	2.6	2.5	2.1
T=38	L=	4.0	3.8	3.6	3.3
T=40	L=	5.5	5.1	4.8	4.6

全盖180°单轴针式铰链2.0 Full Overlay 180Single axis Needle Hinge 2.0

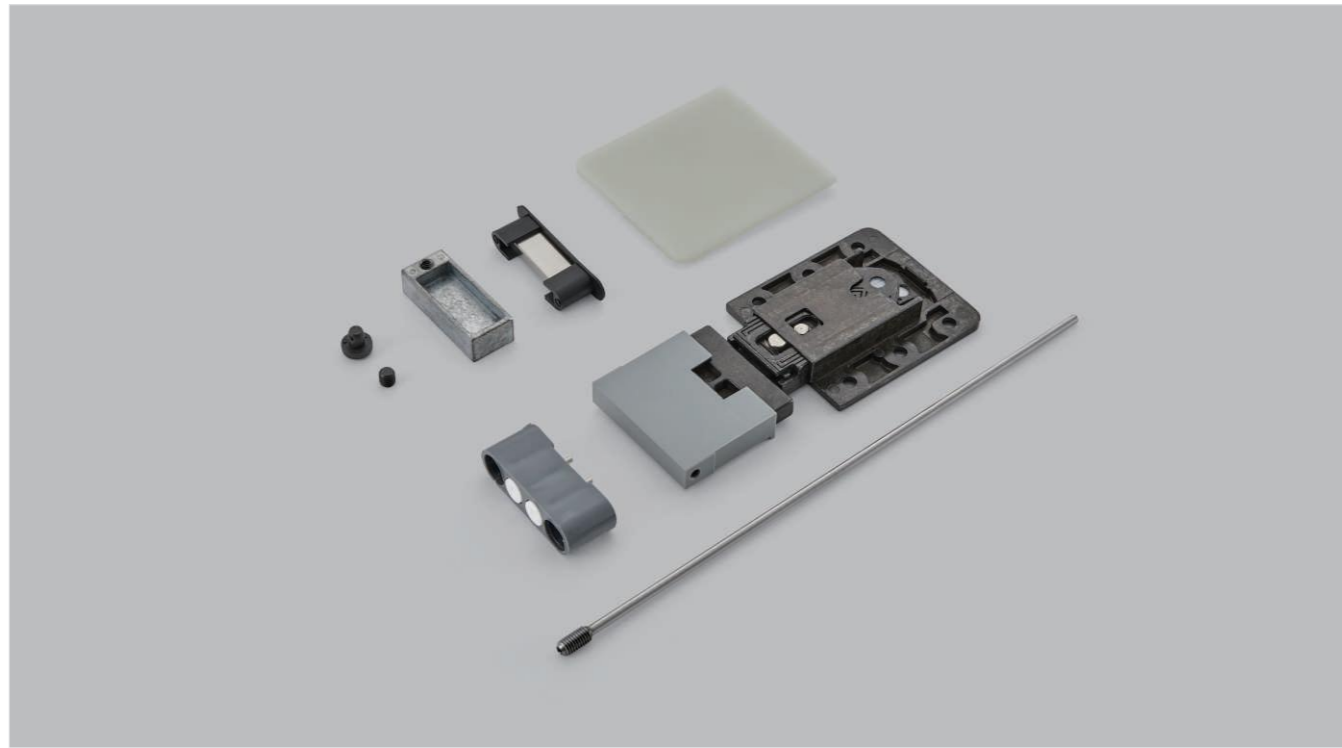

表面处理:黑(可定制)
 产品材质:锌合金、不锈钢轴
 最大负重:一付50KG
 门最大尺寸:高2900mm、
 门宽600mm、门厚35mm
 开启角度:180°-270°
 调节范围:前后调节±3mm、
 上下调节±2.5mm、
 左右调节±3mm
 配件:铰链R、铰链L、
 角码R(选配)、角码L(选配)

Finish: Black(Custom Accepted)
 Material: Zinc Alloy, Stainless steel axis
 Max Load: 50KG /pc
 Max Size of Door : Height:2900mm
 Width:600mm Thickness:350mm
 Open Angle: 180°-270°
 Adjustment Range: Front-Rear+3mm
 Up-Down±2.5mm
 Left-Right + 3mm
 Accessories: Hinge R, hinge L,
 BracketR(option)、Bracket L(option)



产品详情二维码
 订货号 Item number : MK-KY-ZS2.0-180D

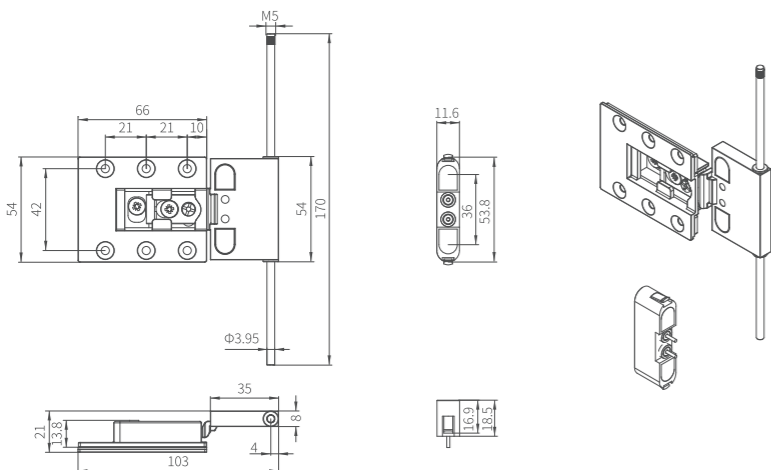

全盖单轴天地铰链安装说明书 Full cover single-axis ground hinge installation manual

一、配件分类 Accessories Category

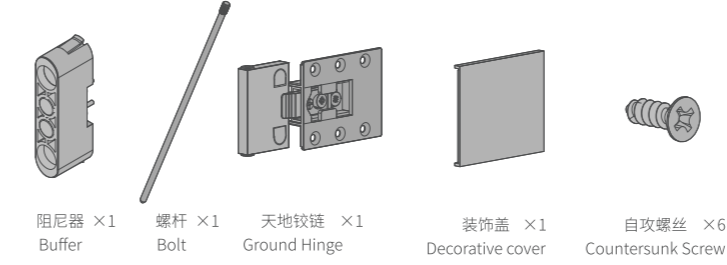

二、门板与柜体参数 Door panel and cabinet parameters

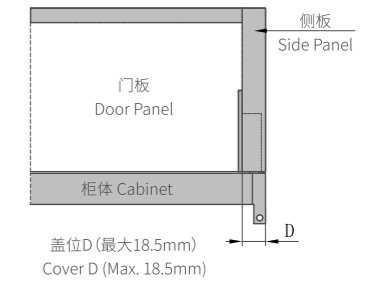

三、安装尺寸 Installation Dimension

1、柜体侧板开孔尺寸图 Cabinet side panel opening dimensions
 单位 Unit : mm

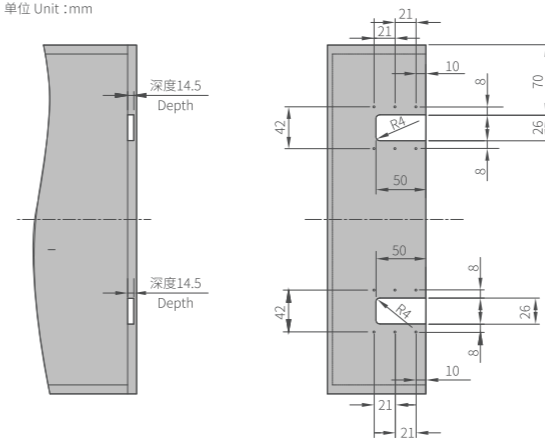

2、铝型材开孔尺寸图 Aluminum profile opening size diagram
 单位 Unit : mm

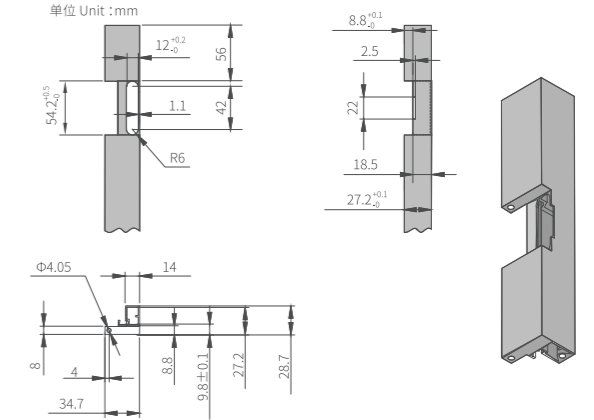

四、安装步骤 Installation Steps

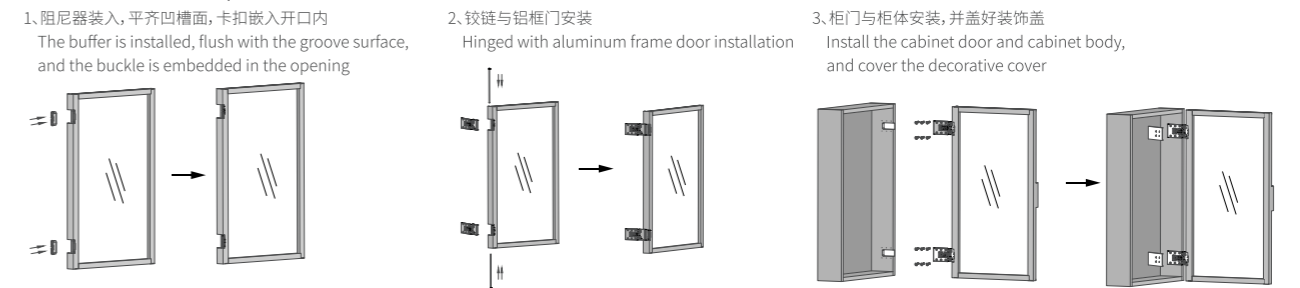

五、门板三维调节 Door panel 3D adjustment

1、左右调节 Left and right adjustment of door panel
 2、上下方向调节 Up and down adjustment of door panel
 3、前后方向调节 Front and rear adjustment of door panel

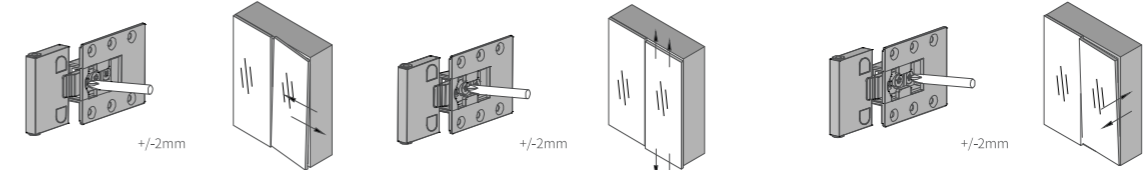

六、柜子倾斜自检 Cabinet tilt self test

1、柜子左右倾斜自检 Cabinet tilt left and right self test
 2、柜子前后倾斜自检 Cabinet tilt back and forth self test



3寸普通青蛙铰链 3 Inches normal frog hinge



开启角度:最大90度
 基材厚度:1.0mm
 门板可选用厚度:14-16mm
 主要材料:冷轧钢板
 表面处理:镍

Opening Angle: 90Max
 Material Thickness: 1.0mm
 Range of door thickness: 14-16mm
 Main material: Cold rolled steel
 Finish: Nickel plating

订货号 Item number : MK-MINI-HH-010

开合状态 Opening and closing condition

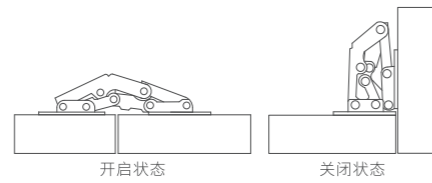
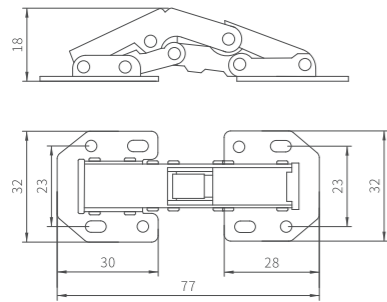

产品详情二维码

4寸普通青蛙铰链 4 Inches normal frog hinge



开启角度:最大90度
 基材厚度:1.2mm/1.5mm
 门板可选用厚度:14-21mm
 主要材料:冷轧钢/304不锈钢
 表面处理:镍

Opening Angle: 90Max
 Material Thickness: 1.2mm/1.5mm
 Range of door thickness: 14-21mm
 Main material: Cold rolled steel / 304 Stainless Steel
 Finish: Nickel plating

订货号 Item number : MK-PT-HH-012/MK-PT-HH-015

开合状态 Opening and closing condition

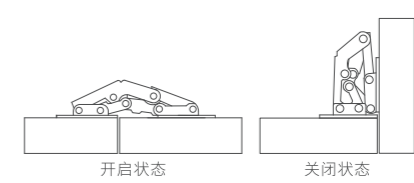
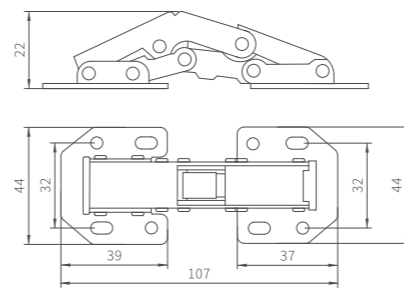

产品详情二维码

4寸液压青蛙铰链 4 Inches normal frog hinge

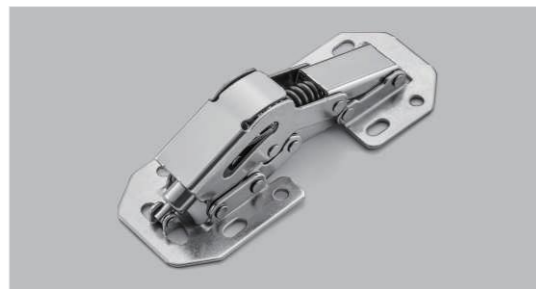

开启角度:最大90度
 基材厚度:1.5mm
 门板可选用厚度:14-21mm
 主要材料:冷轧钢/304不锈钢
 表面处理:镍

Opening Angle: 90Max
 Material Thickness: 1.5mm
 Range of door thickness: 14-21mm
 Main material: Cold rolled steel / 304 Stainless Steel
 Finish: Nickel plating

订货号 Item number : CH-HH-015

开合状态 Opening and closing condition

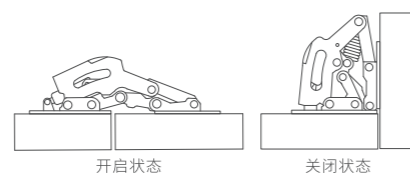
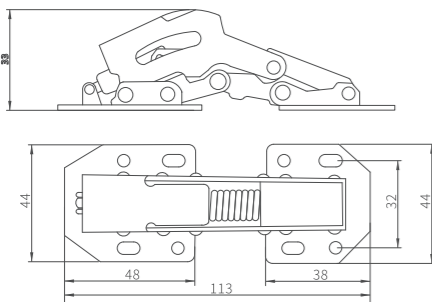

产品详情二维码

90°折叠子弹铰链 90° Folding hinge



开启角度:180°
 基材厚度:1.2mm
 主要材料:冷轧钢
 表面处理:镍

Opening Angle: 180°
 Material Thickness: 1.2mm
 Main material: Cold rolled steel
 Finish: Nickel plating

订货号 Item number : MK-HC-HH-ZDJ180

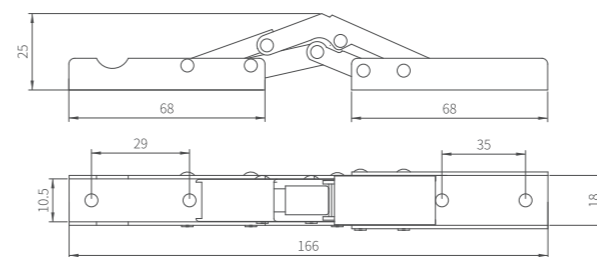

产品详情二维码

200双弹簧普通铰链 200 Double spring normal hinge



开启角度:最大90度
 基材厚度:1.2mm/1.5mm
 门板可选用厚度:14-21mm
 主要材料:冷轧钢
 表面处理:镍
 适用于:房车吊柜、橱柜、衣柜

Opening Angle: 90Max
 Material Thickness: 1.2mm/1.5mm
 Range of door thickness: 14-21mm
 Main material: Cold rolled steel
 Finish: Nickel plating
 Application: Recreational Vehicle Wall Cabinet, Cupboard, Wardrobe

订货号 Item number : MK-PT-HHH200-012/MK-PT-HHH200-015

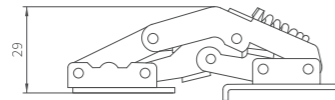
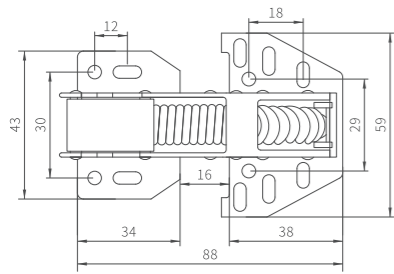

产品详情二维码

170°可调135°铰链 170° Adjustable 135



开启角度:135°-170°可调
 基材厚度:2.0mm
 门板可选用厚度:18-40mm
 产品材质:冷轧钢
 表面处理:镍

Opening Angle: 135°-170° adjustable
 Material Thickness: 2.0mm
 Range of door thickness: 18-40mm
 Material: Cold rolled steel
 Finish: Nickel plating

订货号 Item number : MK-HH-E0H170

直臂(全盖) Full overlay

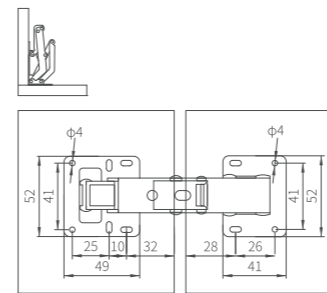

中弯(半盖) Half overlay

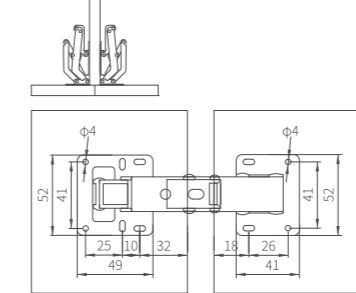

大弯(内嵌) Insert

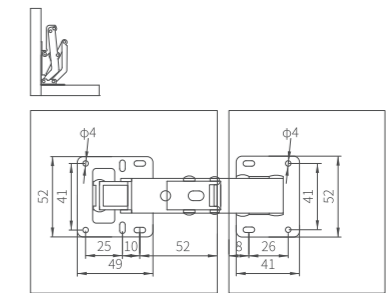

产品详情二维码

PAG 207 200双弹簧液压铰链 200 Double Spring Soft Hinge



开启角度:最大90度
 基材厚度:1.2mm/1.5mm
 门板可选用厚度:14-21mm
 主要材料:冷轧钢/304不锈钢
 表面处理:镍

Opening Angle: 90Max
 Material Thickness: 1.2mm/1.5mm
 Range of door thickness: 14-21mm
 Main material: Cold rolled steel / 304 Stainless Steel
 Finish: Nickel plating

订货号 Item number : MK-PT-HH-012/MK-PT-HH-015

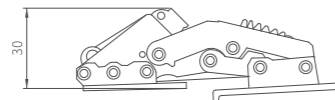
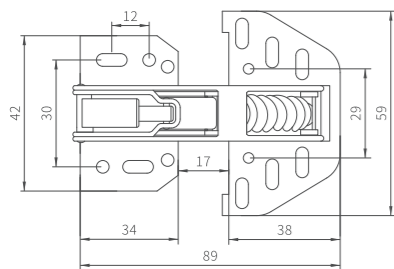

产品详情二维码

170°可调135°液压缓冲铰链 170°Adjustable 135°soft closing hinge

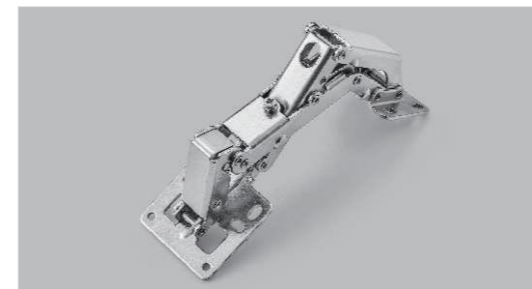

开启角度:135°-170°可调
 基材厚度:2.0mm
 门板可选用厚度:18-40mm
 产品材质:冷轧钢
 表面处理:镍

Opening Angle: 135°-170° adjustable
 Material Thickness: 2.0mm
 Range of door thickness: 18-40mm
 Material: Cold rolled steel
 Finish: Nickel plating

订货号 Item number : MK-HC-HH-E0H170

直臂(全盖) Full overlay

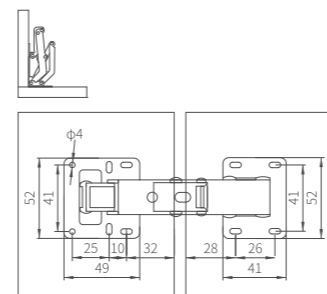

中弯(半盖) Half overlay

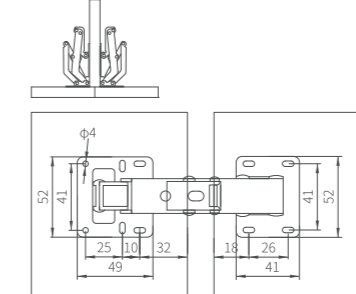

大弯(内嵌) Insert

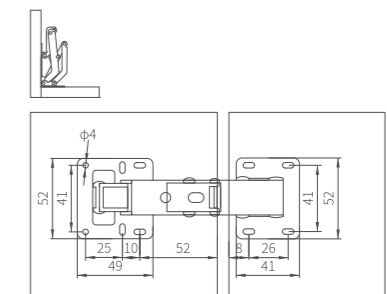

产品详情二维码

165°铝框液压缓冲固装铰链 165° Aluminum soft closing slide on hinge

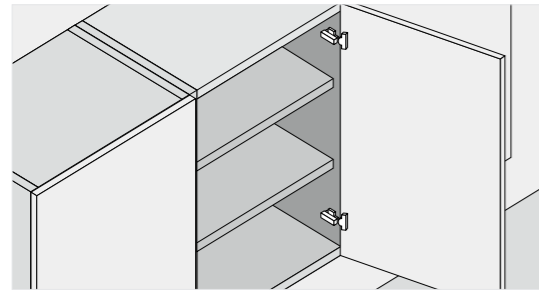

开启角度:175°
适合铝材:20-25mm
基材厚度:1.2mm
铰链头型:方型
主要材料:冷轧钢板
表面处理:枪黑

Open angle: 175°
Applicable aluminum: 20-25mm
Material Thickness: 1.2mm
Head type: Square
Main material: Cold rolled steel
Finish: Gun black

铰杯开孔 Perforation of hinge cup

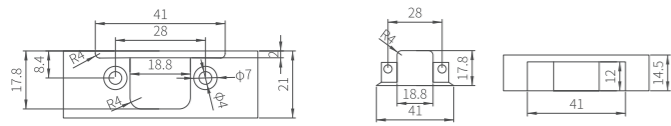

JSD165°液压缓冲拆装铰链 JSD165° Soft Closing Disassembly and Assembly of Hinge

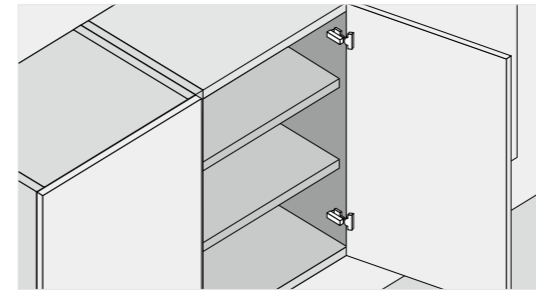

开启角度:165°
铰杯厚度:12mm
铰杯直径:35mm
面板(K)尺寸:3-7mm
门板可选用厚度:15-20mm
主要材料:冷轧钢板
表面处理:镍

Open angle: 165°
Depth of hinge cup: 12mm
Diameter of hinge cup: 35mm
Drilling distance on door(K): 3-7mm
Range of door thickness: 15-20mm
Main material: Cold rolled steel
Finish: Nickel plating

铰杯开孔 Perforation of hinge cup

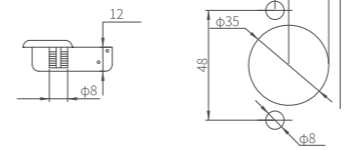

T=侧板厚度
A=门板与侧板间隙
H=底座高度
D=侧板所需盖位
K=面板外线与铰杯钻孔距离
L=面板内线/侧边外线距
S=门板厚度

T=Side panel thickness
A=Gap between door panel and side panel
H=Height of mounting plate
D=Required overlay on the side panel
K=Distance between outside edge on door panel and drilling holes of hinge cup
L=Distance between inside edge on door panel and outside edge on side panel
S=Door panel thickness

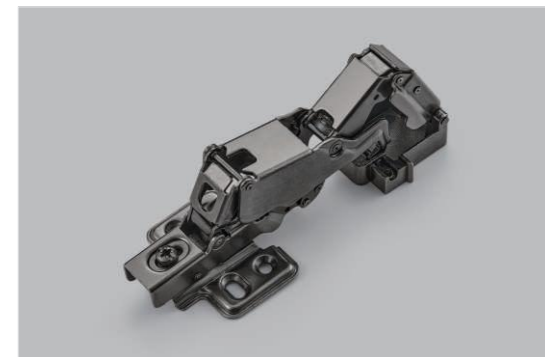

直臂(全盖) Full overlay

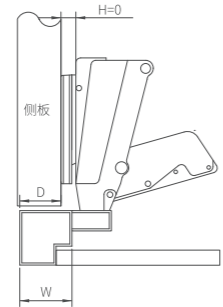

订货号 Item number : MK-HC-HH-QG-LKJL165D

盖位计算值表
Calculation table of overlay

D \ H \ W	3	4	5	6	7	10
0	18	19	20	21	22	25
3	15	16	17	18	19	22
6	12	13	14	15	16	19



直臂(全盖) Full overlay

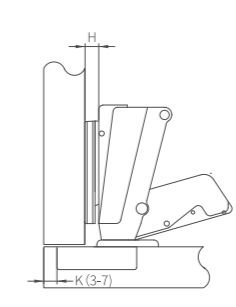

订货号 Item number : MK-HC-JSD-QG-165D

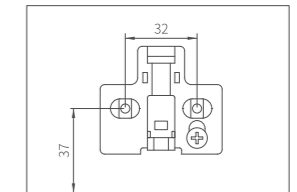

中弯(半盖) Half overlay

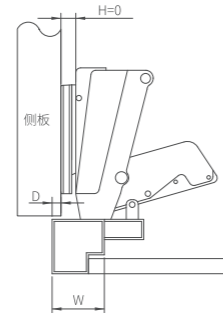

订货号 Item number : MK-HC-HH-BG-LKJL165D

盖位计算值表
Calculation table of overlay

D \ H \ W	3	4	5	6	7	10
0	10	11	12	13	14	17
3	7	8	9	10	11	14
6	4	5	6	7	8	11

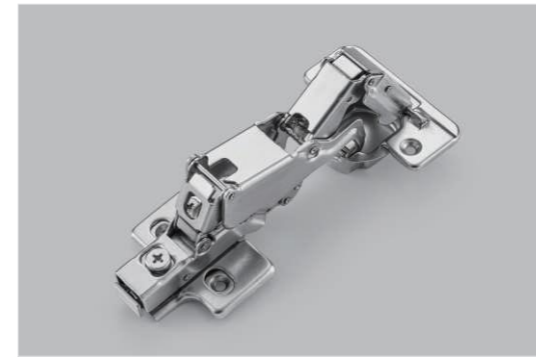

中弯(半盖) Half overlay

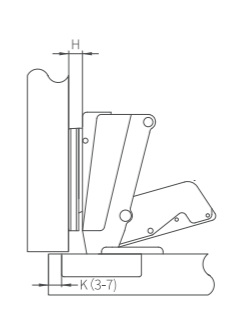

订货号 Item number : MK-HC-JSD-BG-165D

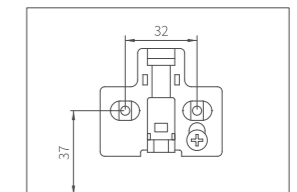

大弯(内嵌) Insert

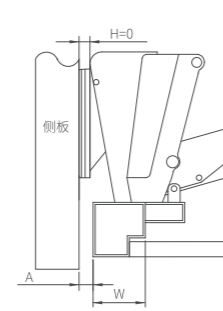

订货号 Item number : MK-HC-HH-NQ-LKJL165D

盖位计算值表
Calculation table of overlay

A \ H \ W	3	4	5	6	7	10
0	-1	0	1	2	3	6

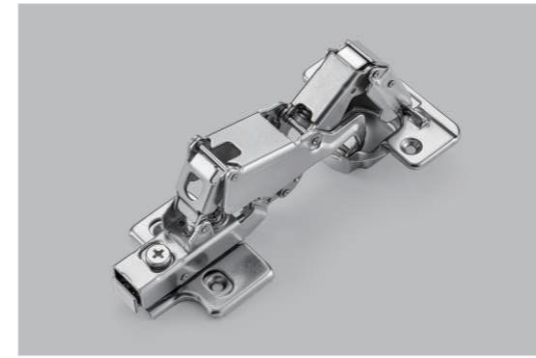

大弯(内嵌) Insert

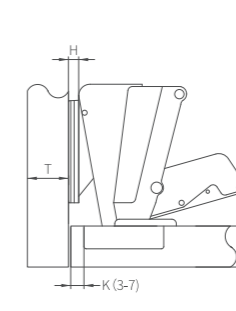

订货号 Item number : MK-HC-JSD-NQ-165D

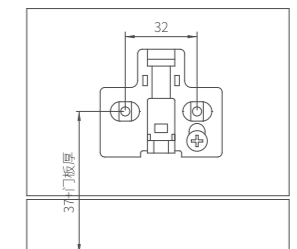

HD一字铰链 Hinge

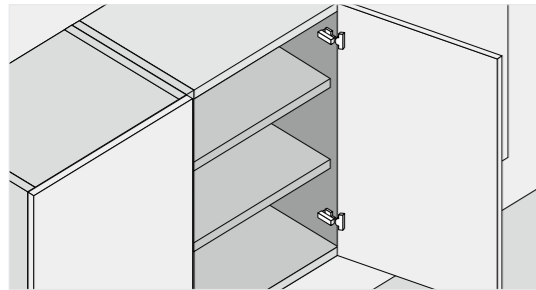

开启角度:110°
 铰杯厚度:11.3mm
 铰杯直径:35mm
 面板(K)尺寸:3-7mm
 主要材料:冷轧钢板
 门板可选厚度 14-23mm
 表面处理:镍、枪黑

Open angle: 110°
 Depth of hinge cup: 11.3mm
 Diameter of hinge cup: 35mm
 Drilling distance on door(K): 3-7mm
 Main material: Cold rolled steel
 Optional thickness of door plate 14-23mm
 Finish: Nickel plating ,Gun black

铰杯开孔 Perforation of hinge cup

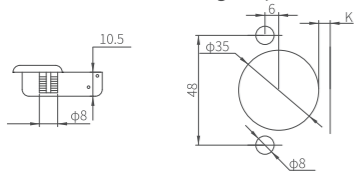

产品详情二维码

T=侧板厚度
 A=门板与侧板间隙
 H=底座高度
 D=侧板所需盖位
 K=面板外线与铰杯钻孔距离
 L=面板内线/侧边外线距
 S=门板厚度

T=Side panel thickness
 A=Gap between door panel and side panel
 H=Height of mounting plate
 D=Required overlay on the side panel
 K=Distance between outside edge on door panel and drilling holes of hinge cup
 L=Distance between inside edge on door panel and outside edge on side panel
 S=Door panel thickness



直臂(全盖) Full overlay

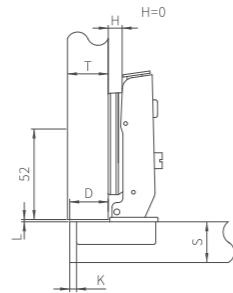

订货号 Item number : MK-HD-QG-YZJ

盖位计算值表
 Calculation table of overlay

D \ H \ K	3	4	5	6	7
0	16	17	18	19	20
2	14	15	16	17	18
4	12	13	14	15	16



中弯(半盖) Half overlay

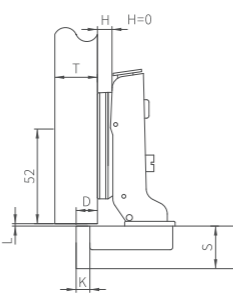

订货号 Item number : MK-HD-BG-YZJ

盖位计算值表
 Calculation table of overlay

D \ H \ K	3	4	5	6	7
0	8	9	10	11	12
2	6	7	8	9	10
4	4	5	6	7	8



大弯(内嵌) Insert

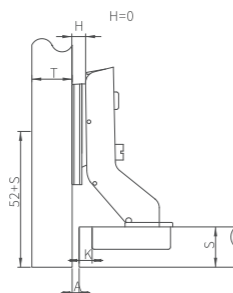

订货号 Item number : MK-HD-NQ-YZJ

盖位计算值表
 Calculation table of overlay

A \ H \ K	3	4	5	6	7
0	-3	-2	-1	0	1
2	-5	-4	-3	-2	-1
4	-7	-6	-5	-4	-3

45°液压缓冲铰链 45°Soft Closing Hinge



铰杯厚度:11.7mm
 铰杯直径:35mm
 面板(K)尺寸:3-7mm
 门板可选用厚度:15-26mm
 主要材料:冷轧钢板
 表面处理:镍
 H=底座高度
 K=面板外线与铰杯钻孔距离
 X=底座安装孔距

Depth of hinge cup: 11.7mm
 Diameter of hinge cup: 35mm
 Drilling distance on door(K): 3-7mm
 Range of door thickness:15-26mm
 Main material: Cold rolled steel
 Finish: Nickel plating
 H=Height of mounting plate
 K=Distance between outside edge on door panel and drilling holes of hinge cup
 X=Install hole distance of the mounting plate

铰杯开孔 Perforation of hinge cup

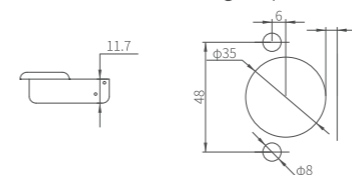

产品详情二维码

45°

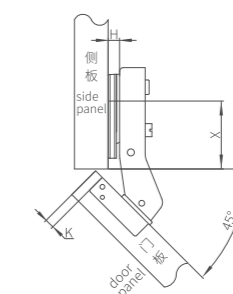

订货号 Item number : MK-HD-01-45D

盖位计算值表
 Calculation table of overlay

H \ K	4	5	6	7				
0	37	4.5	36	5.2	35	5.9	34	6.6
2	37	2.5	36	3.2	35	3.9	34	4.6
4	37	0.5	36	1.2	35	1.9	34	2.6
X								D

90°液压缓冲铰链 90°Soft Closing Hinge



铰杯厚度:11.5mm
 铰杯直径:35mm
 面板(K)尺寸:3-7mm
 门板可选用厚度:12-26mm
 主要材料:冷轧钢板
 表面处理:镍
 H=底座高度
 K=面板外线与铰杯钻孔距离
 X=底座安装孔距

Depth of hinge cup: 11.5mm
 Diameter of hinge cup: 35mm
 Drilling distance on door(K): 3-7mm
 Range of door thickness:12-26mm
 Main material: Cold rolled steel
 Finish: Nickel plating plating
 H=Height of mounting plate
 K=Distance between outside edge on door panel and drilling holes of hinge cup
 X=Install hole distance of the mounting plate

铰杯开孔 Perforation of hinge cup

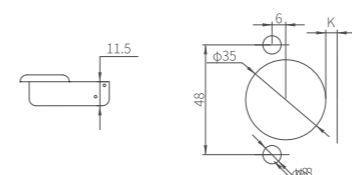

产品详情二维码

90°

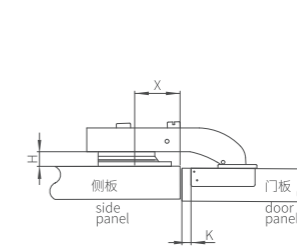

订货号 Item number : MK-HD-01-90D

盖位计算值表
 Calculation table of overlay

H \ K	4	5	6	7	
0	20	2.8	19	2.8	
2	20	0.8	19	0.8	
4	20	1.2	19	1.2	
X					D

135°固装铰链 135°Slide on hinge



铰杯厚度:11.5mm
 铰杯直径:35mm
 面板(K)尺寸:3-7mm
 门板可选用厚度:15-26mm
 主要材料:冷轧钢板
 表面处理:镍
 H=底座高度
 K=面板外线与铰杯钻孔距离
 X=底座安装孔距

Depth of hinge cup: 11.5mm
 Diameter of hinge cup: 35mm
 Drilling distance on door(K): 3-7mm
 Range of door thickness:15-26mm
 Main material: Cold rolled steel
 Finish: Nickel plating
 H=Height of mounting plate
 K=Distance between outside edge on door panel and drilling holes of hinge cup
 X=Install hole distance of the mounting plate

铰杯开孔 Perforation of hinge cup

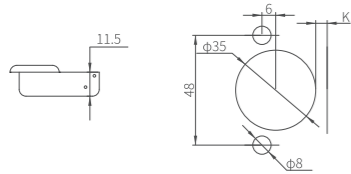

135°

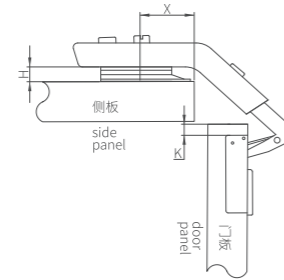

订货号 Item number : MK-HD-01-135D

盖位计算值表
 Calculation table of overlay

	门板厚度<18mm Door panel thickness <18mm	22mm<门板厚度>18mm 22mm< Door panel thickness >18mm
H	2	0
X	37	37

HD165°固装缓冲铰链 HD165° Slide Soft Closing Hinge

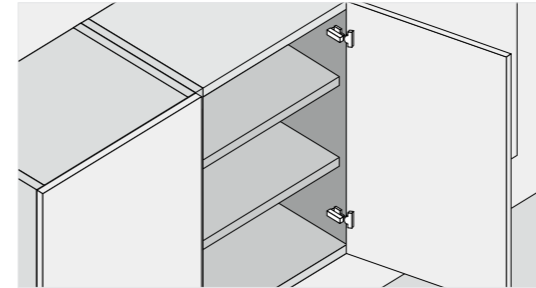

开启角度:165°
 铰杯厚度:12mm
 铰杯直径:35mm
 面板(K)尺寸:3-7mm
 门板可选用厚度:15-26mm
 主要材料:冷轧钢板
 表面处理:镍

Open angle: 165°
 Depth of hinge cup: 12mm
 Diameter of hinge cup: 35mm
 Drilling distance on door(K): 3-7mm
 Range of door thickness:15-26mm
 Main material: Cold rolled steel
 Finish: Nickel plating

铰杯开孔 Perforation of hinge cup

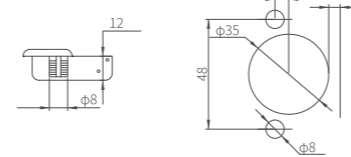

T=侧板厚度
 A=门板与侧板间隙
 H=底座高度
 D=侧板所需盖位
 K=面板外线与铰杯钻孔距离
 L=面板内线/侧边外线距
 S=门板厚度

T=Side panel thickness
 A=Gap between door panel and side panel
 H=Height of mounting plate
 D=Required overlay on the side panel
 K=Distance between outside edge on door panel and drilling holes of hinge cup
 L=Distance between inside edge on door panel and outside edge on side panel
 S=Door panel thickness

直臂(全盖) Full overlay

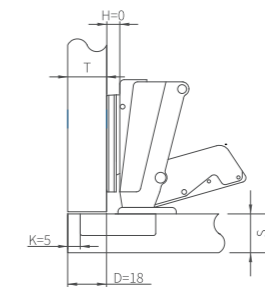
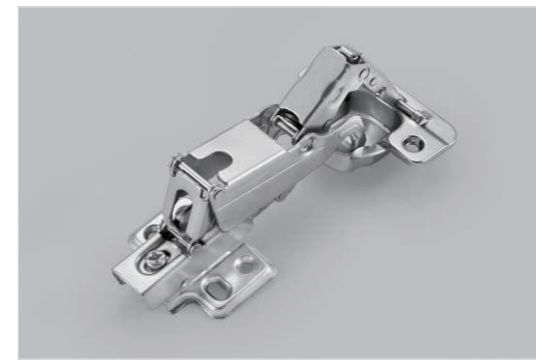

订货号 Item number : MK-HD-01-QG-165D

盖位计算值表
 Calculation table of overlay

D \ H \ K	3	4	5	6	7
0	16	17	18	19	20
3	13	14	15	16	17

中弯(半盖) Half overlay

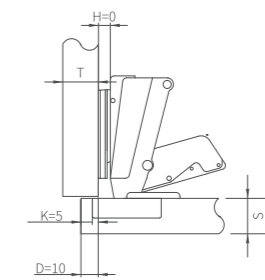

订货号 Item number : MK-HD-01-BQ-165D

盖位计算值表
 Calculation table of overlay

D \ H \ K	3	4	5	6	7
0	8	9	10	11	12
3	5	6	7	8	9

大弯(内嵌) Insert

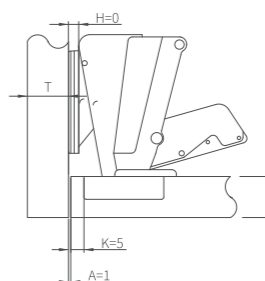

订货号 Item number : MK-HD-01-NQ-165D

盖位计算值表
 Calculation table of overlay

A \ H \ K	3	4	5	6	7
0	-3	-2	-1	0	1

MK-FBJ-62-54-51 35翻板铰链 MK-FBJ-62-54-51 35 Flip Hinges



开启角度: 110°
 铰杯厚度: 11.8mm
 铰杯直径: 35mm
 门板可选用厚度: ≥15mm
 主要材料: 锌合金
 表面处理: 镍

Open angle: 110°
 Depth of hinge cup: 11.8mm
 Diameter of hinge cup: 35mm
 Range of door thickness: ≥15mm
 Main material: Zinc alloy
 Finish: Nickel plating

订货号 Item number : MK-FBJ-62-54-51

铰杯开孔 Perforation of hinge cup

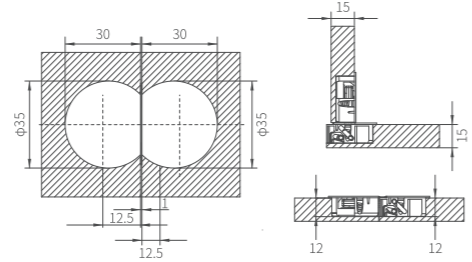
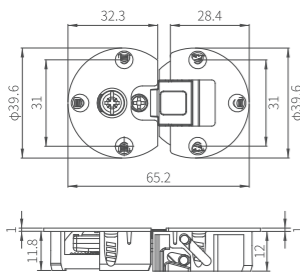

产品详情二维码



KY铰链(一段力液压) KY Hinge(one way soft closing)

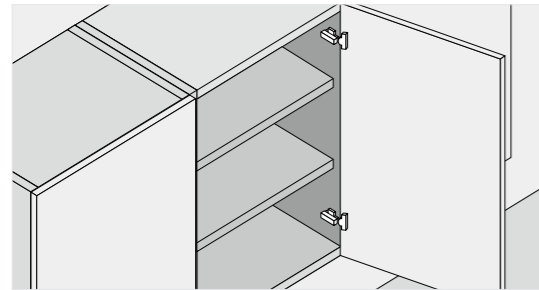

开启角度:105°
 铰杯厚度:11.5mm
 铰杯直径:35mm
 面板(K)尺寸:3-7mm
 主要材料:冷轧钢板
 表面处理:镍

Open angle: 105°
 Depth of hinge cup: 11.5mm
 Diameter of hinge cup: 35mm
 Drilling distance on door(K): 3-7mm
 Main material: Cold rolled steel
 Finish: Nickel plating

铰杯开孔 Perforation of hinge cup

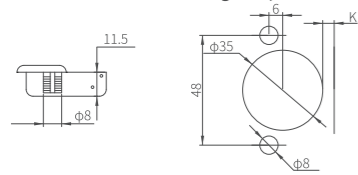

T=侧板厚度
 A=门板与侧板间隙
 H=底座高度
 D=侧板所需盖位
 K=面板外线与铰杯钻孔距离
 L=面板内线/侧边外线距
 S=门板厚度

T=Side panel thickness
 A=Gap between door panel and side panel
 H=Height of mounting plate
 D=Required overlay on the side panel
 K=Distance between outside edge on door panel and drilling holes of hinge cup
 L=Distance between inside edge on door panel and outside edge on side panel
 S=Door panel thickness



直臂(全盖) Full overlay

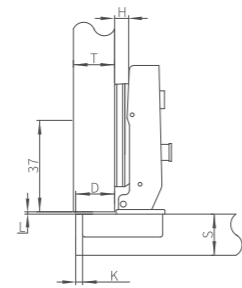

订货号 Item number : MK-KY-01-QG

盖位计算值表
 Calculation table of overlay

D \ H \ K	3	4	5	6	7
0	16	17	18	19	20
2	14	15	16	17	18

$H=13+K-D$



中弯(半盖) Half overlay

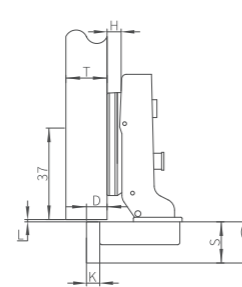

订货号 Item number : MK-KY-01-BG

盖位计算值表
 Calculation table of overlay

D \ H \ K	3	4	5	6	7
0	8	9	10	11	12
2	6	7	8	9	10

$H=5+K-D$



大弯(内嵌) Insert

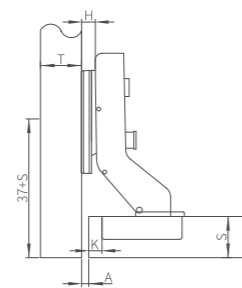

订货号 Item number : MK-KY-01-NG

盖位计算值表
 Calculation table of overlay

A \ H \ K	3	4	5	6	7
0	1	0	-1	-2	-3
2	3	2	1	0	-1

$H=A+K-4$

BS铰链(二段力液压) BS Hinge (two way soft closing)

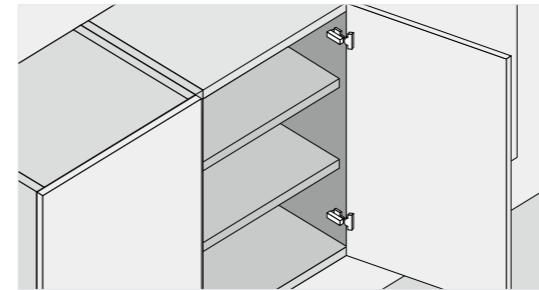

开启角度:105°
 铰杯厚度:11.5mm
 铰杯直径:35mm
 面板(K)尺寸:3-7mm
 主要材料:冷轧钢板
 表面处理:镍

Open angle: 105°
 Depth of hinge cup: 11.5mm
 Diameter of hinge cup: 35mm
 Drilling distance on door(K): 3-7mm
 Main material: Cold rolled steel
 Finish: Nickel plating

铰杯开孔 Perforation of hinge cup

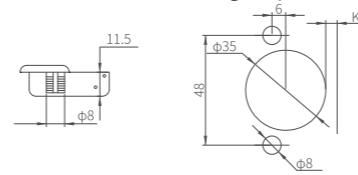

T=侧板厚度
 A=门板与侧板间隙
 H=底座高度
 D=侧板所需盖位
 K=面板外线与铰杯钻孔距离
 L=面板内线/侧边外线距
 S=门板厚度

T=Side panel thickness
 A=Gap between door panel and side panel
 H=Height of mounting plate
 D=Required overlay on the side panel
 K=Distance between outside edge on door panel and drilling holes of hinge cup
 L=Distance between inside edge on door panel and outside edge on side panel
 S=Door panel thickness



直臂(全盖) Full overlay

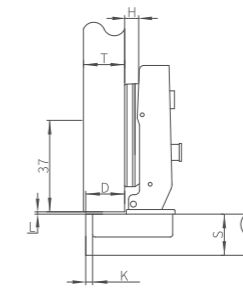

订货号 Item number : MK-BS-02-QG

盖位计算值表
 Calculation table of overlay

D \ H \ K	3	4	5	6	7
0	16	17	18	19	20
2	14	15	16	17	18

$H=13+K-D$



中弯(半盖) Half overlay

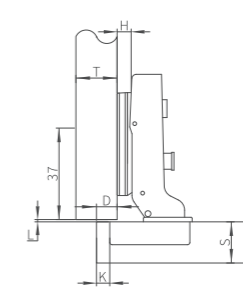

订货号 Item number : MK-BS-02-BG

盖位计算值表
 Calculation table of overlay

D \ H \ K	3	4	5	6	7
0	8	9	10	11	12
2	6	7	8	9	10

$H=5+K-D$



大弯(内嵌) Insert

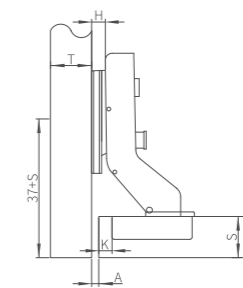

订货号 Item number : MK-BS-02-NG

盖位计算值表
 Calculation table of overlay

A \ H \ K	3	4	5	6	7
0	1	0	-1	-2	-3
2	3	2	1	0	-1

$H=A+K-4$

铝框铰链 Aluminum Profile Hinge

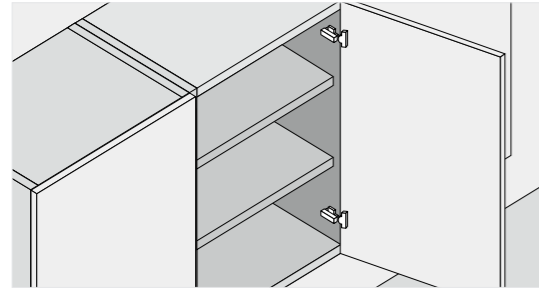

开启角度:105°
铝框铰杯可选尺寸:28mm
铝型材可选用P宽度:
19mm-22mm
主要材料:冷轧钢板
表面处理:枪色、镍



产品详情二维码

Open angle: 105°
Size of hinge cup: 28mm
Applicable aluminum profile width (P):
19mm-22mm
Main material: Cold rolled steel
Finish: Gun-black, Nickel plating

铰杯开孔 Perforation of hinge cup

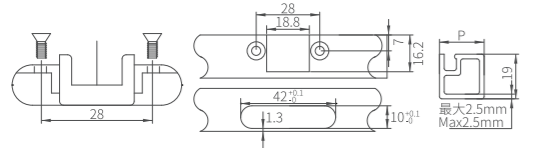

T=侧板厚度
A=门板与侧板间隙
H=底座高度
D=侧板所需盖位

T=Side panel thickness
A=Gap between door panel and side panel
H=Height of mounting plate
D=Required overlay on the side panel



直臂(全盖) Full overlay

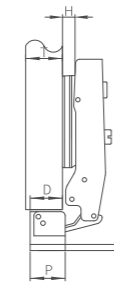

订货号 Item number : MK-LF-01-QG-LK

盖位计算值表
Calculation table of overlay

D \ P	19	20	21	22	23
0	17	18	19	20	21
2	15	16	17	18	19

$H = -2 + P - D$



中弯(半盖) Half overlay

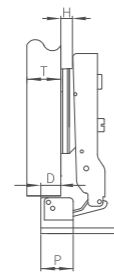

订货号 Item number : MK-LF-01-BG-LK

盖位计算值表
Calculation table of overlay

D \ P	19	20	21	22	23
0	8	9	10	11	12
2	6	7	8	9	10

$H = -11 + P - D$



大弯(内嵌) Insert

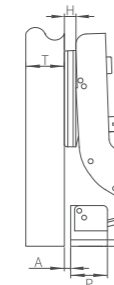

订货号 Item number : MK-LF-01-NQ-LK

盖位计算值表
Calculation table of overlay

A \ P	19	20	21	22	23
0	1	0	-1	-2	-3
2	3	2	1	0	-1

$H = -20 + P + A$

HD三维铰链 HD 3D Hinge

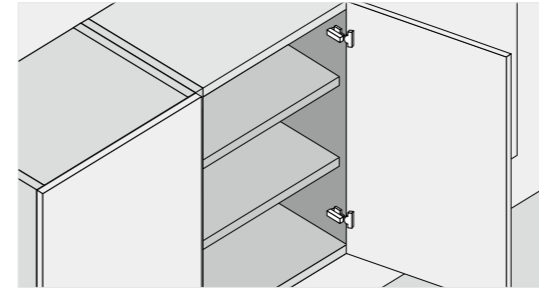

开启角度:105°
铰杯厚度:11.8mm
铰杯直径:35mm
面板(K)尺寸:3-7mm
门板可选用厚度:14-22mm
主要材料:冷轧钢板
表面处理:镍

Open angle: 105°
Depth of hinge cup: 11.8mm
Diameter of hinge cup: 35mm
Drilling distance on door(K): 3-7mm
Range of door thickness: 14-22mm
Main material: Cold rolled steel
Finish: Nickel plating

铰杯开孔 Perforation of hinge cup

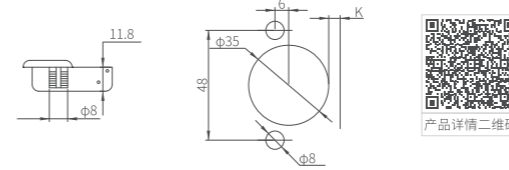

T=侧板厚度
A=门板与侧板间隙
H=底座高度
D=侧板所需盖位
K=面板外线与铰杯钻孔距离
L=面板内线/侧边外线距
S=门板厚度

T=Side panel thickness
A=Gap between door panel and side panel
H=Height of mounting plate
D=Required overlay on the side panel
K=Distance between outside edge on door panel and drilling holes of hinge cup
L=Distance between inside edge on door panel and outside edge on side panel
S=Door panel thickness



直臂(全盖) Full overlay

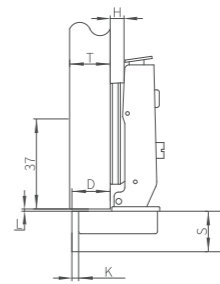

订货号 Item number : MK-HD-01-QG-SW

盖位计算值表
Calculation table of overlay

D \ K	3	4	5	6	7
0	18	19	20	21	22
2	16	17	18	19	20

$H = 14 + K - D$



中弯(半盖) Half overlay

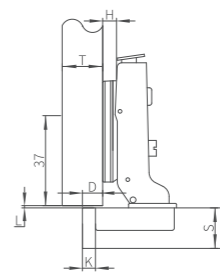

订货号 Item number : MK-HD-01-BG-SW

盖位计算值表
Calculation table of overlay

D \ K	3	4	5	6	7
0	9	10	11	12	13
2	7	8	9	10	11

$H = 5 + K - D$



大弯(内嵌) Insert

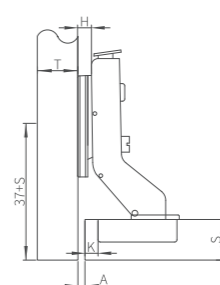

订货号 Item number : MK-HD-01-NQ-SW

盖位计算值表
Calculation table of overlay

A \ K	3	4	5	6	7
0	0	-1	-2	-3	-4
2	2	1	0	-1	-2

$H = A + K - 4$

HD304不锈钢拆卸液压铰链 HD304 Stainless Steel Clip-on Soft Closing Hinge

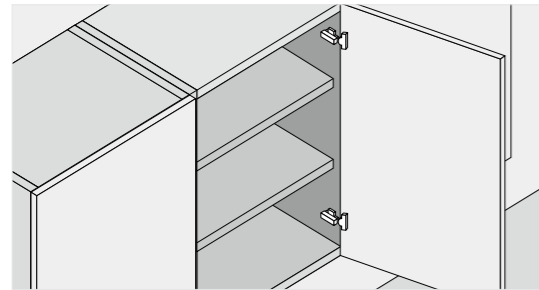

开启角度:105°
 铰杯厚度:11.8mm
 铰杯直径:35mm
 面板(K)尺寸:3-7mm
 主要材料:不锈钢
 表面处理:镍

Open angle: 105°
 Depth of hinge cup: 11.8mm
 Diameter of hinge cup: 35mm
 Drilling distance on door(K): 3-7mm
 Main material: Stainless steel
 Finish: Nickel plating

铰杯开孔 Perforation of hinge cup

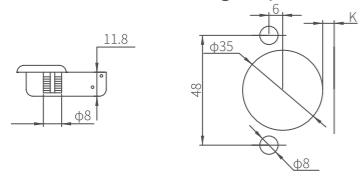

T=侧板厚度
 A=门板与侧板间隙
 H=底座高度
 D=侧板所需盖位
 K=面板外线与铰杯钻孔距离
 L=面板内线/侧边外线距
 S=门板厚度

T=Side panel thickness
 A=Gap between door panel and side panel
 H=Height of mounting plate
 D=Required overlay on the side panel
 K=Distance between outside edge on door panel and drilling holes of hinge cup
 L=Distance between inside edge on door panel and outside edge on side panel
 S=Door panel thickness



直臂(全盖) Full overlay

订货号 Item number : MK-HD-01-QG-CX304

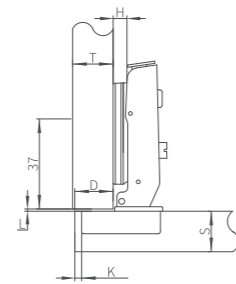

盖位计算值表
 Calculation table of overlay

D \ H \ K	3	4	5	6	7
0	17	18	19	20	21
2	15	16	17	18	19

$H=13+K-D$



中弯(半盖) Half overlay

订货号 Item number : MK-HD-01-BG-CX304

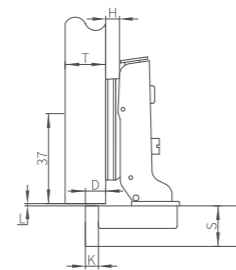

盖位计算值表
 Calculation table of overlay

D \ H \ K	3	4	5	6	7
0	8	9	10	11	12
2	6	7	8	9	10

$H=5+K-D$



大弯(内嵌) Insert

订货号 Item number : MK-HD-01-NQ-CX304

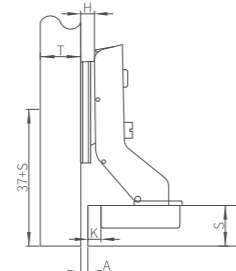

盖位计算值表
 Calculation table of overlay

A \ H \ K	3	4	5	6	7
0	1	0	-1	-2	-3
2	3	2	1	0	-1

$H=A+K-4$

HD35杯短臂液压铰链 HD 35 Cup Short Arm Soft Closing Hinge

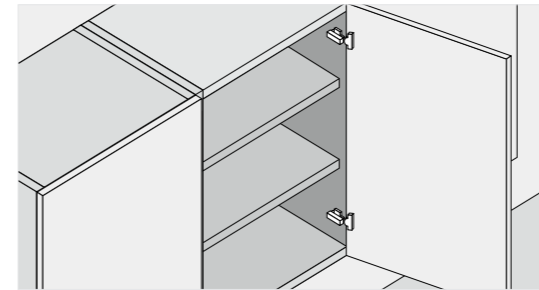

开启角度:110°
 铰杯厚度:11.8mm
 铰杯直径:35mm
 面板(K)尺寸:3-5mm
 门板可选用厚度:14-23mm
 主要材料:冷轧钢板
 表面处理:镍

Open angle: 110°
 Depth of hinge cup: 11.8mm
 Diameter of hinge cup: 35mm
 Drilling distance on door(K): 3-5mm
 Range of door thickness:14-23mm
 Main material: Cold rolled steel
 Finish: Nickel plating

铰杯开孔 Perforation of hinge cup

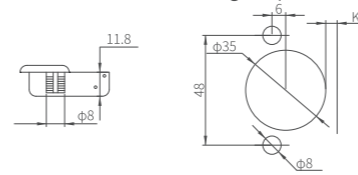

A=门板与侧板间隙
 H=底座高度
 D=侧板所需盖位
 K=面板外线与铰杯钻孔距离

A=Gap between door panel and side panel
 H=Height of mounting plate
 D=Required overlay on the side panel
 K=Distance between outside edge on door panel and drilling holes of hinge cup



直臂(全盖) Full overlay

订货号 Item number : MK-HD-01-QG-FD3

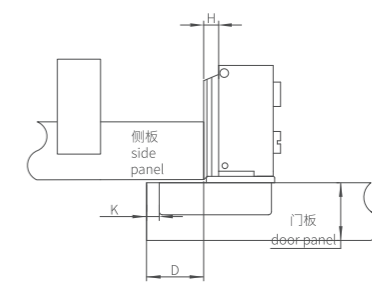

1"



中弯(半盖) Half overlay

订货号 Item number : MK-HD-01-BG-FD3

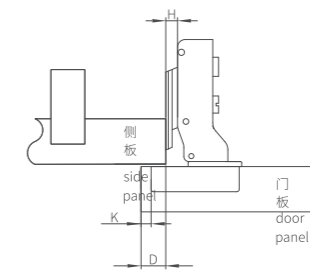

5/8"



大弯(内嵌) Insert

订货号 Item number : MK-HD-01-NQ-FD3

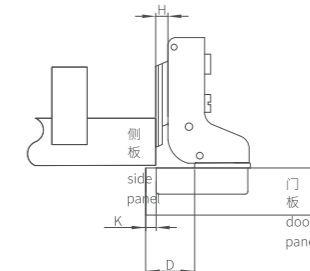

1/4"

HD拆卸液压铰链 HD Clip-on Soft Closing Hinge

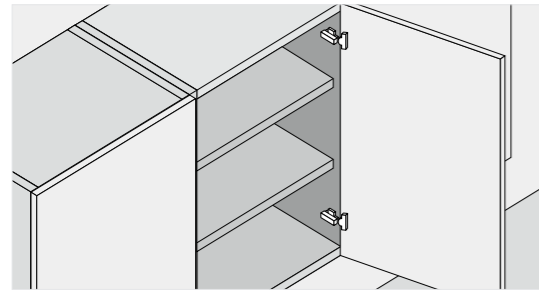

开启角度:105°
 铰杯厚度:11.8mm
 铰杯直径:35mm
 面板(K)尺寸:3-7mm
 主要材料:冷轧钢板
 表面处理:镍

Open angle: 105°
 Depth of hinge cup: 11.8mm
 Diameter of hinge cup: 35mm
 Drilling distance on door(K): 3-7mm
 Main material: Cold rolled steel
 Finish: Nickel plating

铰杯开孔 Perforation of hinge cup

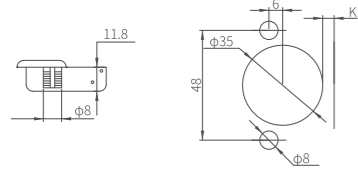

T=侧板厚度
 A=门板与侧板间隙
 H=底座高度
 D=侧板所需盖位
 K=面板外线与铰杯钻孔距离
 L=面板内线/侧边外线距
 S=门板厚度

T=Side panel thickness
 A=Gap between door panel and side panel
 H=Height of mounting plate
 D=Required overlay on the side panel
 K=Distance between outside edge on door panel and drilling holes of hinge cup
 L=Distance between inside edge on door panel and outside edge on side panel
 S=Door panel thickness



直臂(全盖) Full overlay

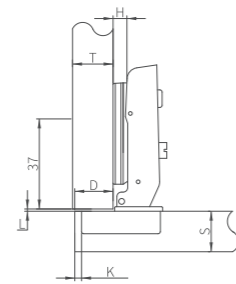

订货号 Item number : MK-HD-01-QG-CX

盖位计算值表
 Calculation table of overlay

D \ H \ K	3	4	5	6	7
0	17	18	19	20	21
2	15	16	17	18	19

$H=13+K-D$

CJ26杯液压铰链 CJ 26 Cup Soft Closing Hinge

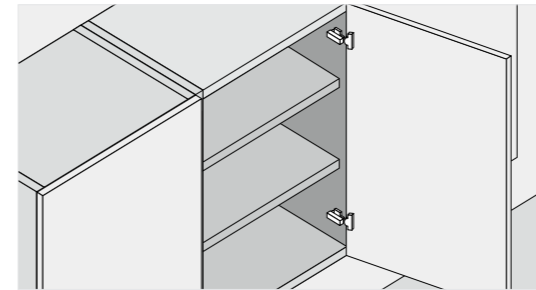

开启角度:105°
 铰杯厚度:10.5mm
 铰杯直径:26mm
 面板(K)尺寸:3-5mm
 门板可选用厚度:14-22mm
 主要材料:冷轧钢板
 表面处理:镍

Open angle: 105°
 Depth of hinge cup: 10.5mm
 Diameter of hinge cup: 26mm
 Drilling distance on door(K): 3-5mm
 Range of door thickness:14-22mm
 Main material: Cold rolled steel
 Finish: Nickel plating

铰杯开孔 Perforation of hinge cup

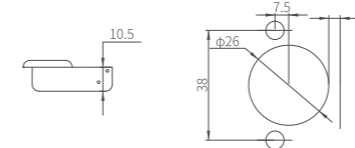

T=侧板厚度
 A=门板与侧板间隙
 H=底座高度
 D=侧板所需盖位
 K=面板外线与铰杯钻孔距离
 L=面板内线/侧边外线距
 S=门板厚度

T=Side panel thickness
 A=Gap between door panel and side panel
 H=Height of mounting plate
 D=Required overlay on the side panel
 K=Distance between outside edge on door panel and drilling holes of hinge cup
 L=Distance between inside edge on door panel and outside edge on side panel
 S=Door panel thickness



直臂(全盖) Full overlay

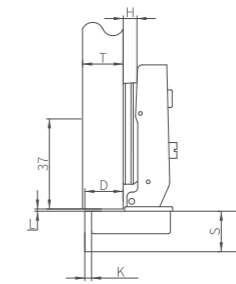

订货号 Item number : MK-CJ-01-QG-26

盖位计算值表
 Calculation table of overlay

D \ H \ K	3	4	5
0	15	16	17
2	13	14	15

$H=12+K-D$



中弯(半盖) Half overlay

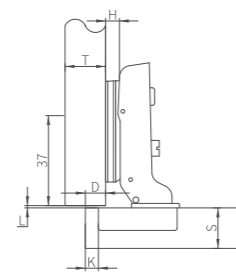

订货号 Item number : MK-HD-01-BG-CX

盖位计算值表
 Calculation table of overlay

D \ H \ K	3	4	5	6	7
0	8	9	10	11	12
2	6	7	8	9	10

$H=5+K-D$



中弯(半盖) Half overlay

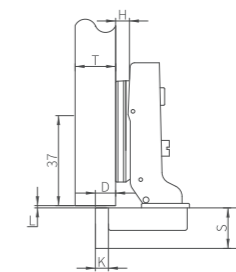

订货号 Item number : MK-CJ-01-BG-26

盖位计算值表
 Calculation table of overlay

D \ H \ K	3	4	5
0	7	8	9
2	4	5	6

$H=3+K-D$



大弯(内嵌) Insert

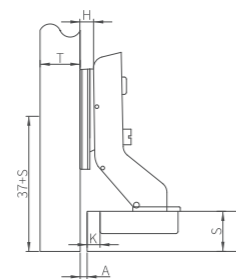

订货号 Item number : MK-HD-01-NQ-CX

盖位计算值表
 Calculation table of overlay

A \ H \ K	3	4	5	6	7
0	1	0	-1	-2	-3
2	3	2	1	0	-1

$H=A+K-4$



大弯(内嵌) Insert

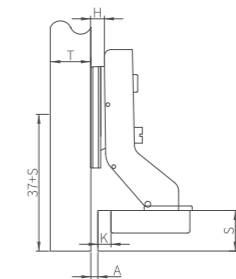

订货号 Item number : MK-CJ-01-NQ-26

盖位计算值表
 Calculation table of overlay

A \ H \ K	3	4	5
0	2	1	0

$H=A+K-4$



MeiKi明希®

3D ADJUSTABLE CONCEALED HINGE SERIES
三维可调暗铰系列

HIDDEN SHAPE SILENT OPENING AND CLOSING
藏形匿迹 无声开合

嵌入式安装, 隐于无形
三维可调节, 精准贴合

Embedded installation, hidden in invisible
3D adjustable, accurate fit

MK-NN-HY150KG-B 三维可调暗铰 MK-NN-HY150KG-B 3D adjustable concealed hinge

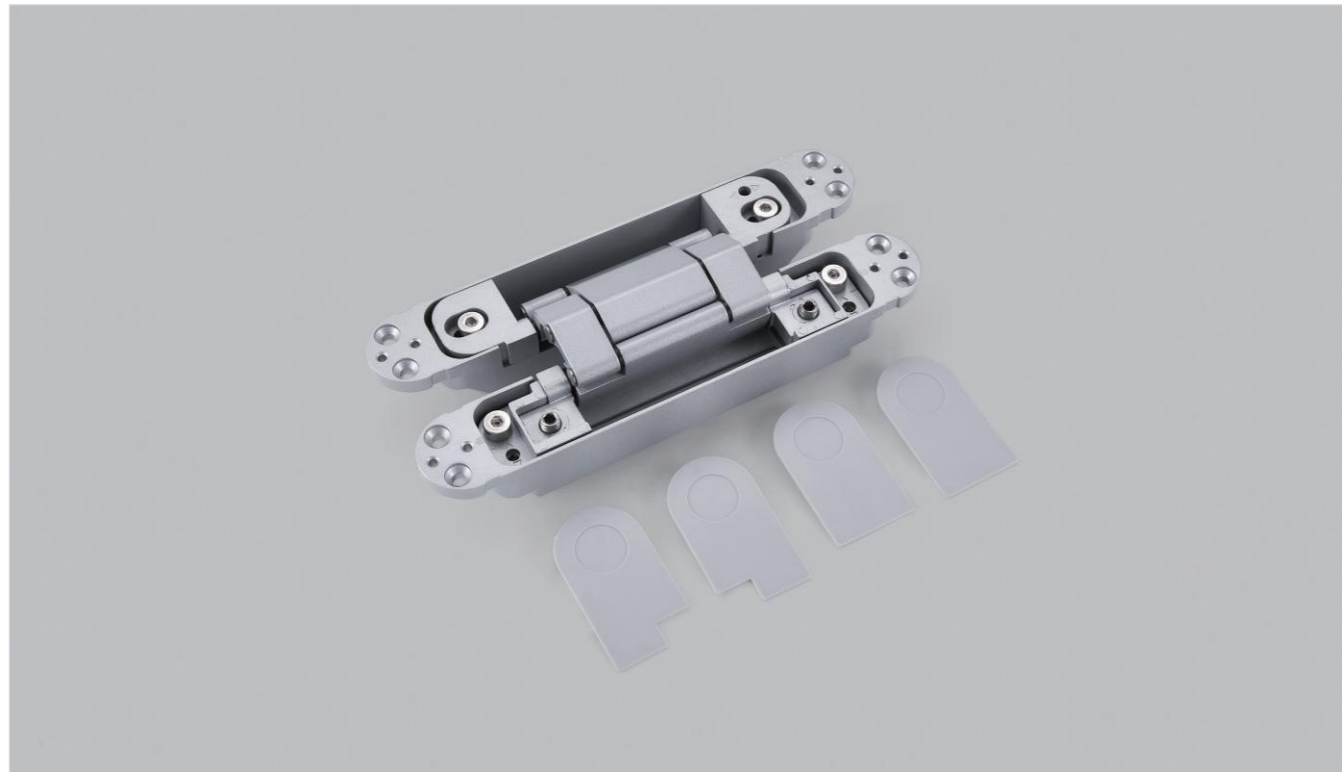

订货号 Item number	MK-NN-HY150KG-B
适用门类 Suitable door type	嵌入式安装 Flush mounted
可调范围 Adjustable range	上下 Vertical +/- 3mm、左右 Horizontal +/- 2.5mm、前后 Depth +/- 1mm
开启角度 Opening angle	180°
最大承重 Max door loading	单扇门2个铰链 2 Hinges per door leaf 150Kg
门扇最小厚度 Min door thickness	45mm
门扇最大宽度 Max door width	1500mm
产品材质 Material	铰链体 Hinge: 锌合金 Zinc alloy; 接合器 Joiner: 铝合金 Aluminium alloy; 主轴 Spindle: 不锈钢/钢 Stainless steel/Steel
表面处理 Finish	珍珠铬 Pearl chrome、镍 Nickel plating、镀铜 Copper plating、喷漆 Spray paint

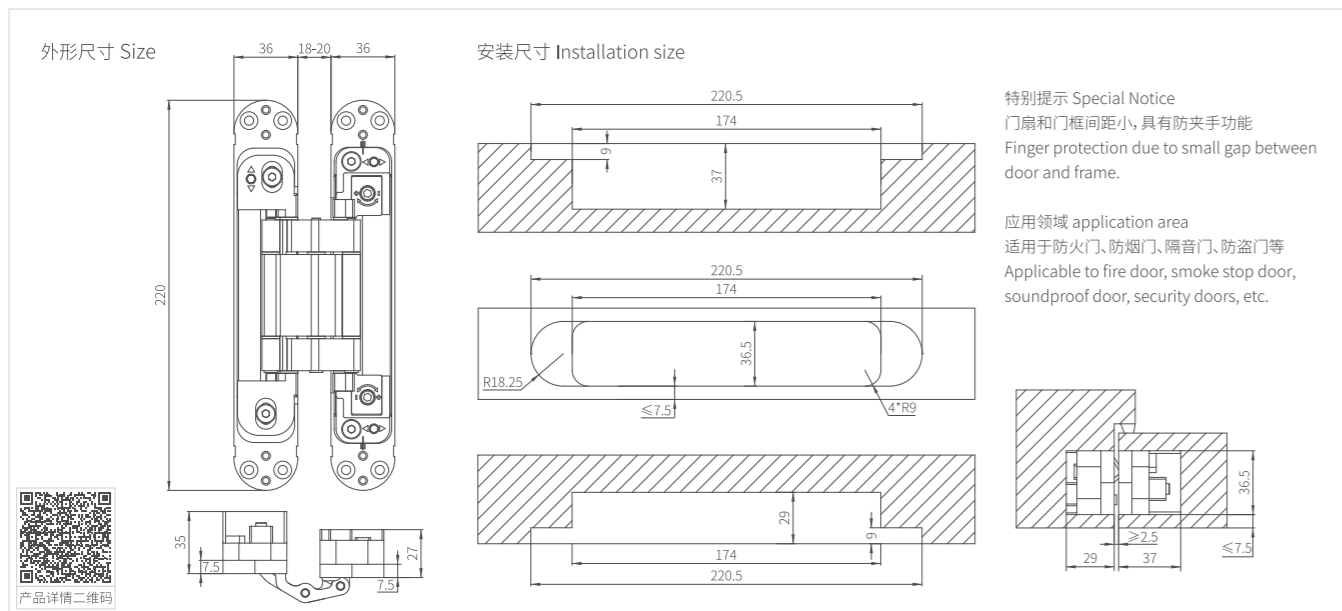

MK-NN-ZCG40 三维可调暗铰 MK-NN-ZCG40 3D adjustable concealed hinge

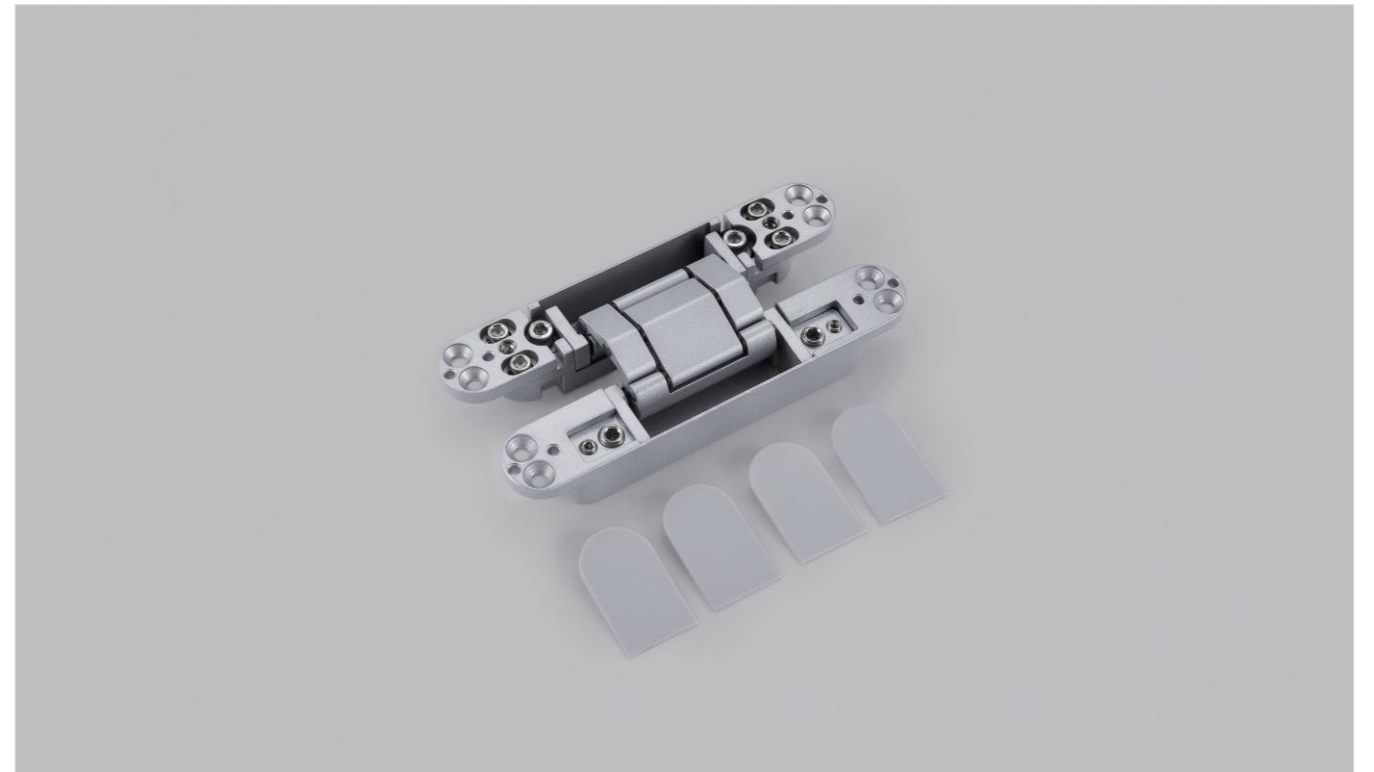

订货号 Item number	MK-NN-ZCG40
适用门类 Suitable door type	嵌入式安装 Flush mounted
可调范围 Adjustable range	上下 Vertical +/- 3mm、左右 Horizontal +/- 2mm、前后 Depth +/- 1mm
开启角度 Opening angle	180°
最大承重 Max door loading	单扇门2个铰链 2 Hinges per door leaf 40Kg
门扇最小厚度 Min door thickness	35mm
门扇最大宽度 Max door width	850mm
产品材质 Material	铰链体 Hinge: 锌合金 Zinc alloy; 接合器 Joiner: 铝合金 Aluminium alloy; 主轴 Spindle: 不锈钢/钢 Stainless steel/Steel
表面处理 Finish	珍珠铬 Pearl chrome、镍 Nickel plating、镀铜 Copper plating、喷漆 Spray paint

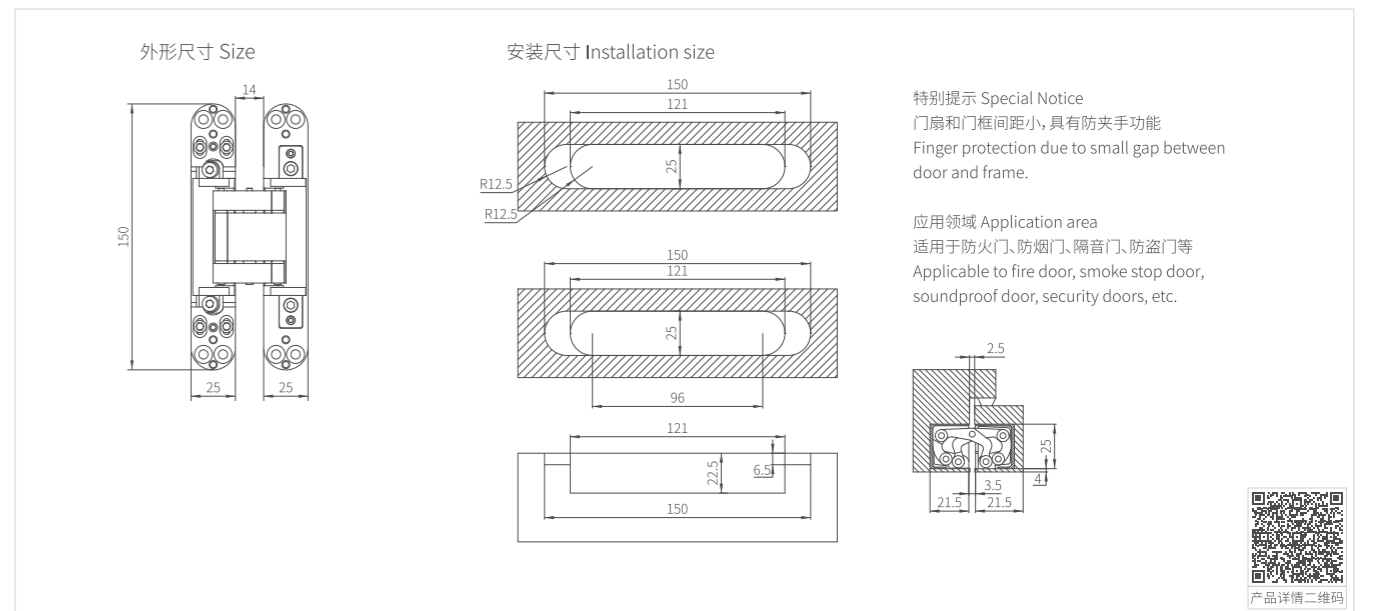

MK-LAMP-HES3D-70 LAMP三维调节暗铰 MK-LAMP-HES3D-70 adjustable concealed hinge



订货号 Item number	MK-LAMP-HES3D-70
适用门厚 Applicable door thickness	19mm以上, 嵌入式安装 Above 19mm, Flush mounted
可调范围 Adjustable range	上下 Vertical +/- 1.5mm、左右 Horizontal +/- 1.5mm、前后 Depth +/- 1mm
开启角度 Opening angle	180°
最大承重 Max door loading	9KG (2个使用)、12KG (3个使用) 9KG (2 PCS), 12KG (3 PCS)
门扇最小高度 Min door Altitude	1200mm
门扇最大宽度 Max door width	600mm
产品材质 Material	锌合金 Zinc alloy
表面处理 Finish	银色 Silver、香槟色 Champagne、黑色 Black

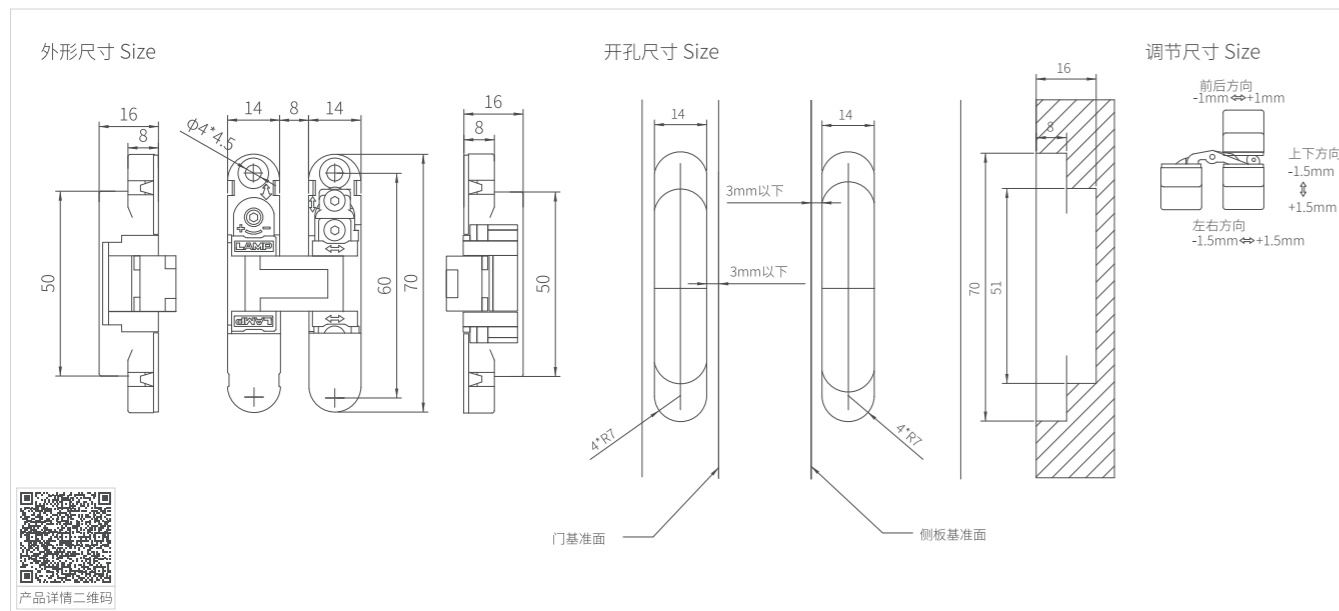



MeiKi明希®

LOCK SERIES
锁具系列

CALM OUTSTANDING GUARD IN THE CORE
沉稳出众 守护于芯

营造一隅私密空间
解锁生活之美
Create a private space
Unlock the beauty of life

MK-XBS-102A16-40 智能密码锁 MK-XBS-102A16-40 Smart password lock



订货号 Item number	MK-XBS-102A16-40
产品材质 Material	锌合金 Zinc alloy, 铁 Iron
表面颜色 Finish	红铜 Pure copper

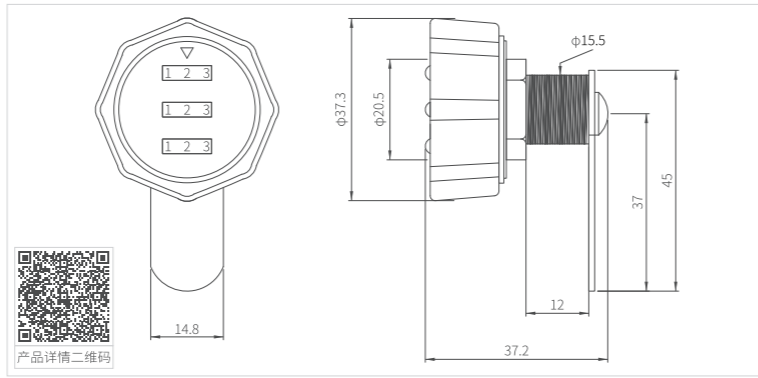

产品详情二维码

MK-XBS-138-1 锌合金智能锁 MK-XBS-138-1 Zinc alloy smart lock



订货号 Item number	MK-XBS-138-1
产品材质 Material	锌合金 Zinc alloy, 铁 Iron
表面颜色 Finish	珍珠铬 Pearl chrome

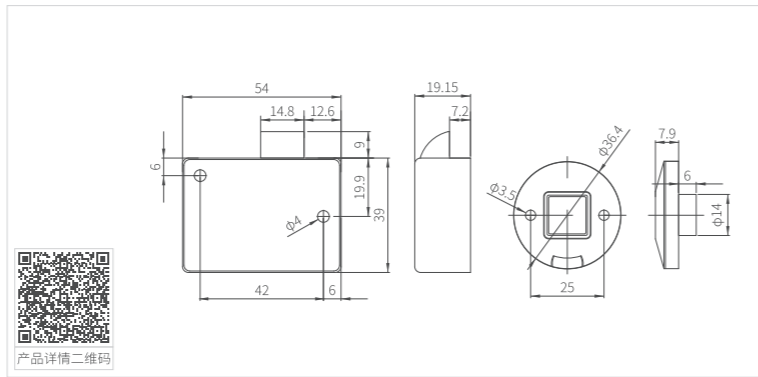

产品详情二维码

MK-XBS-103-1 锌合金智能密码锁 MK-XBS-103-1 Zinc alloy smart password lock



订货号 Item number	MK-XBS-103-1
产品材质 Material	锌合金 Zinc alloy, 铁 Iron
表面颜色 Finish	枪黑 Gun-black

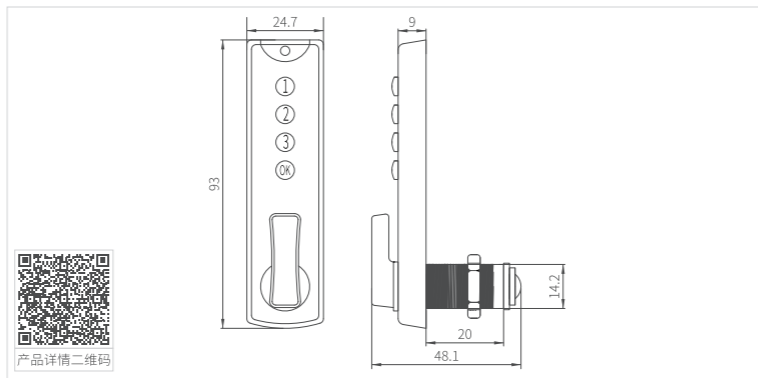

产品详情二维码

MK-XBS-103-2 锌合金智能密码锁 MK-XBS-103-2 Zinc alloy smart password lock



订货号 Item number	MK-XBS-103-2
产品材质 Material	锌合金 Zinc alloy, 铁 Iron
表面颜色 Finish	珍珠铬 Pearl chrome

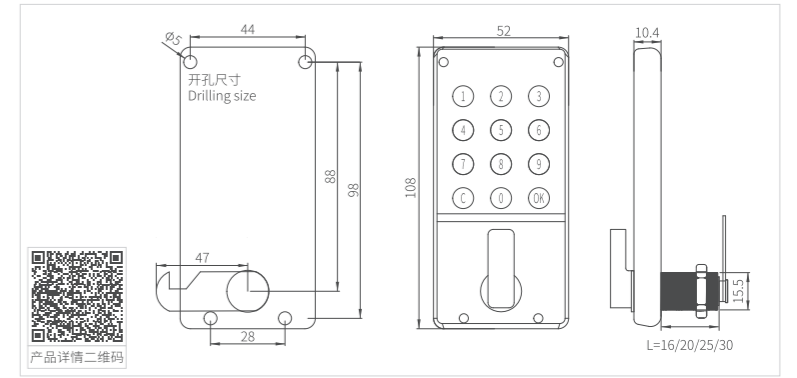

产品详情二维码

MK-XBS-103-3 锌合金智能密码锁 MK-XBS-103-3 Zinc alloy smart password lock



订货号 Item number	MK-XBS-103-3
产品材质 Material	锌合金 Zinc alloy, 铁 Iron
表面颜色 Finish	哑黑 Matte black

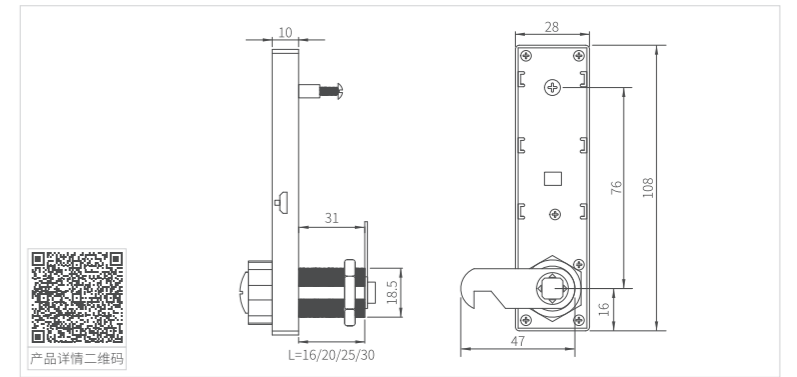

产品详情二维码

MK-XBS-103-4 锌合金智能密码锁 MK-XBS-103-4 Zinc alloy smart password lock



订货号 Item number	MK-XBS-103-4
产品材质 Material	锌合金 Zinc alloy, 铁 Iron
表面颜色 Finish	珍珠镍 Satin nickel

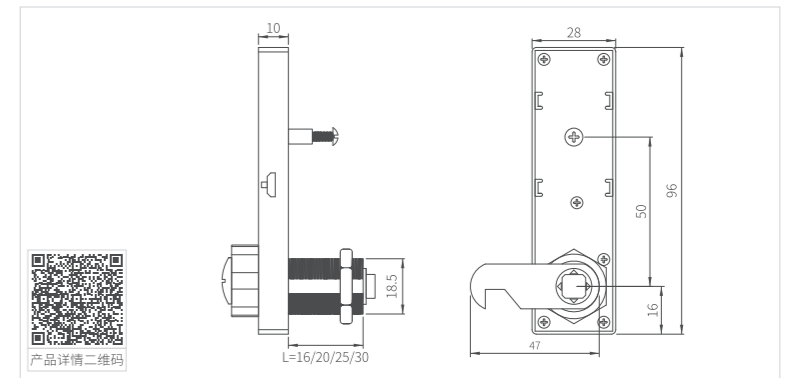

产品详情二维码

MK-CLW-SLS 三联锁 MK-CLW-SLS Three linkage lock



订货号 Item number	MK-CLW-SLS
产品材质 Material	锌合金 Zinc alloy, 铝合金 Aluminium alloy, 铁 Iron
表面颜色 Finish	本色+黑色 Natural color+black

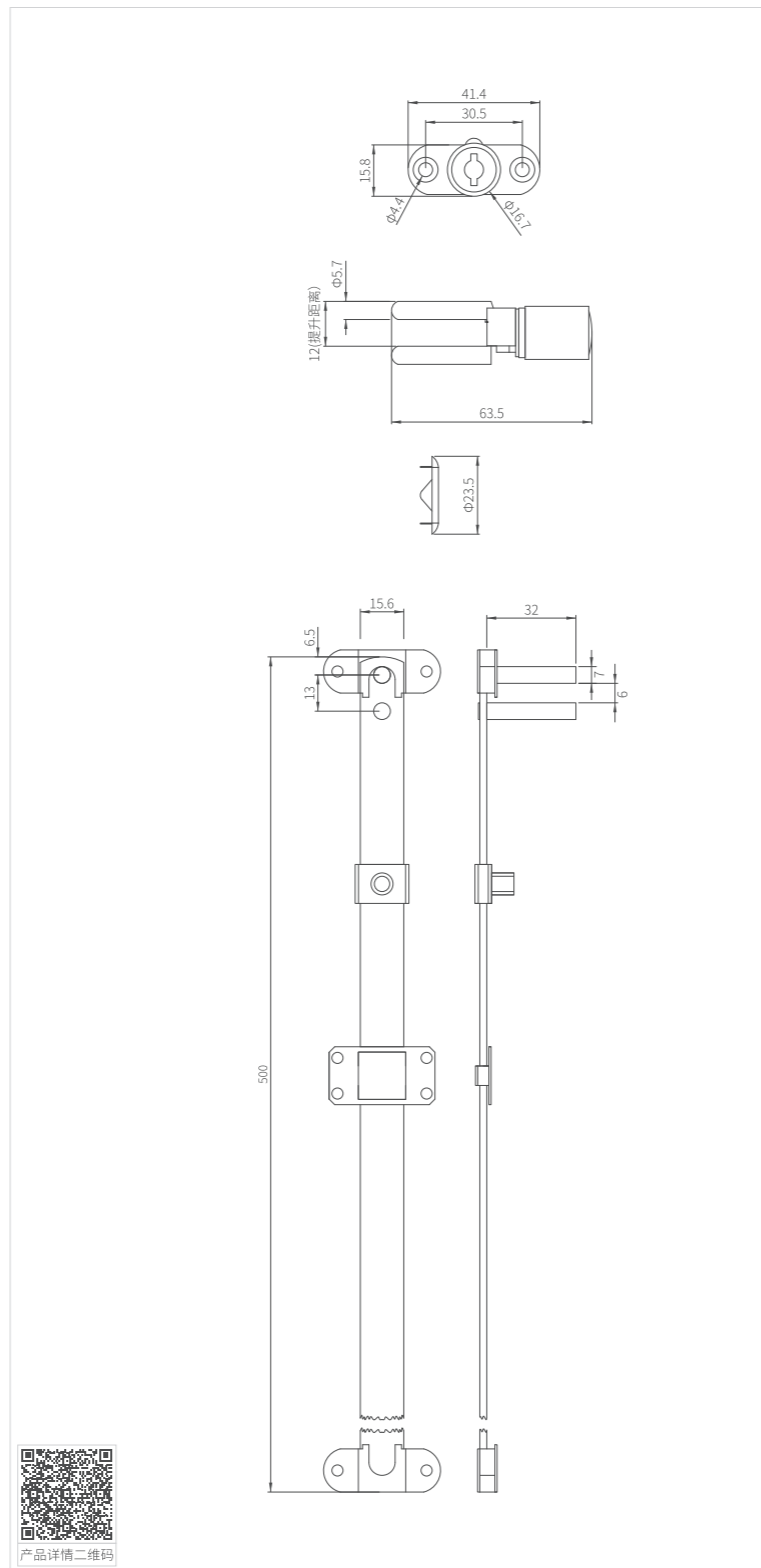

MK-XBS-103-40 锌合金密码锁 (黑色、仿金、古铜、枪色) MK-XBS-103-40 Zinc alloy password lock(Black, Golden, Bronze, Gun-black)



订货号 Item number	MK-XBS-103-40
产品材质 Material	锌合金 Zinc alloy, 铁 Iron
表面颜色 Finish	黑色 Black, 仿金 Golden, 古铜 Bronze, 枪色 Gun-black

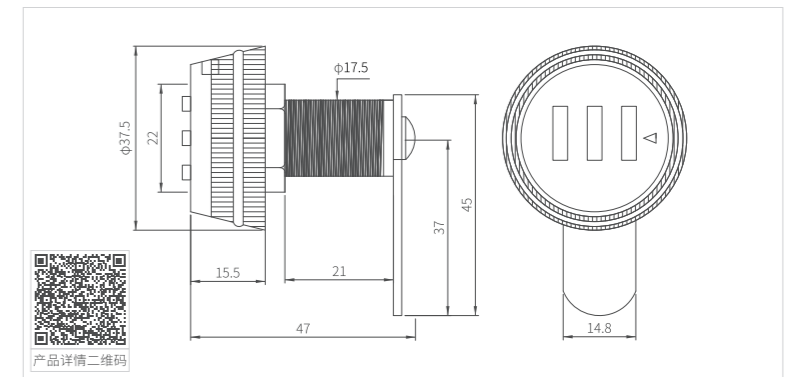

MK-CLW-138-22 抽屉锁 MK-CLW-138-22 Drawer lock



订货号 Item number	MK-CLW-138-22
产品材质 Material	锌合金 Zinc alloy, 铁 Iron
表面颜色 Finish	黑色 Black

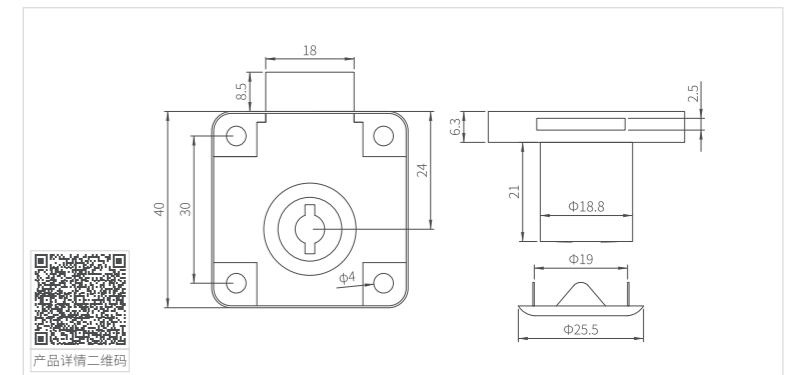

MK-MWD-138 锌合金抽屉锁 MK-MWD-138 Zinc alloy Drawer lock



订货号 Item number	MK-MWD-138
产品材质 Material	锌合金 Zinc alloy, 铁 Iron
表面颜色 Finish	黑色 Black

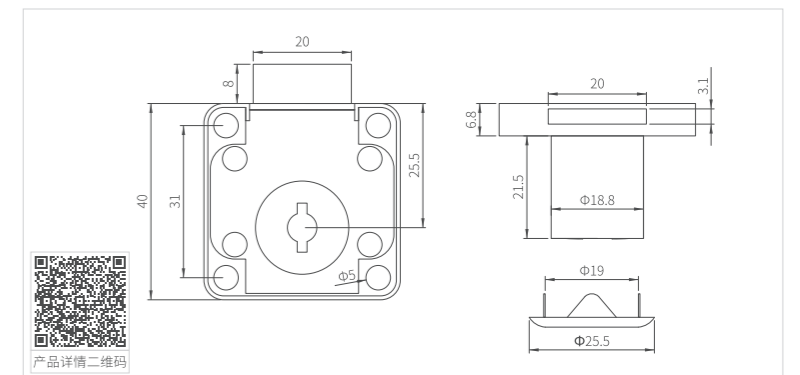



MeiKi明希®

ACCESSORY SERIES
小件系列

SMALL THINGS GO A LONG WAY
小物件 大用途

让生活的质感
流淌于每一处细节
Let life texture
Flow in every detail

MK-BBK-31-01-27 1#背板扣 MK-BBK-31-01-27 1# Plate back holder

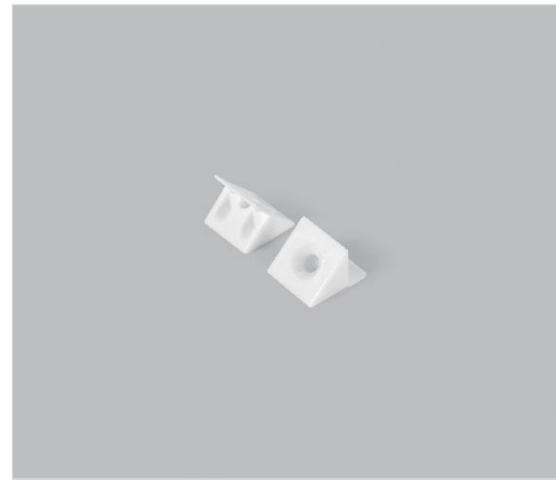

订货号 Item number	MK-BBK-31-01-27
产品材质 Material	塑料 Plastic
表面处理 Finish	白色 White

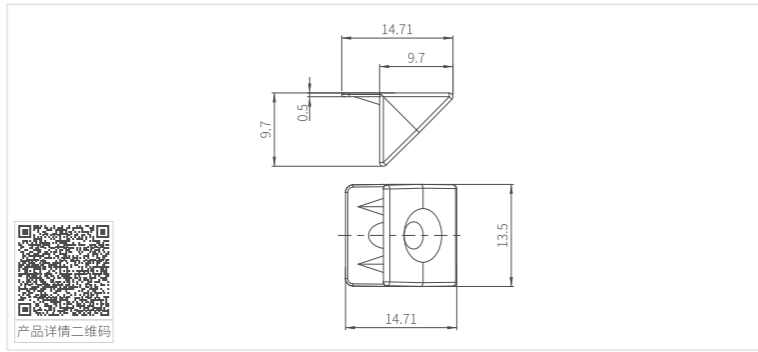

MK-JM-31-01-18 1#小号带盖角码 MK-JM-31-01-18 1# Bracket



订货号 Item number	MK-JM-31-01-18
产品材质 Material	塑料 Plastic
表面处理 Finish	白色 White

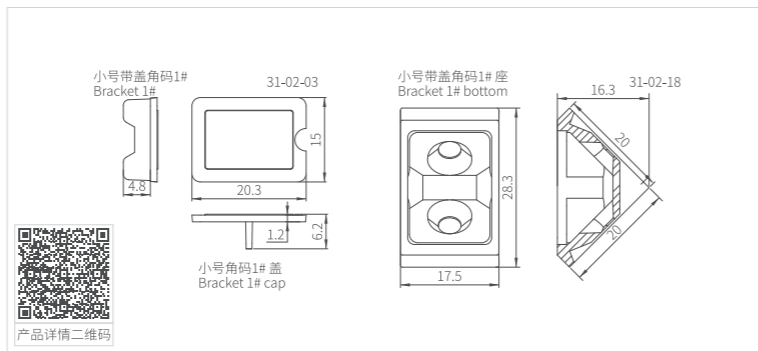

MK-JG-32-01-01 38胶盖 MK-JG-32-01-01 38 Plastic cap



订货号 Item number	MK-JG-32-01-01
产品材质 Material	塑料 Plastic
表面处理 Finish	白色 White

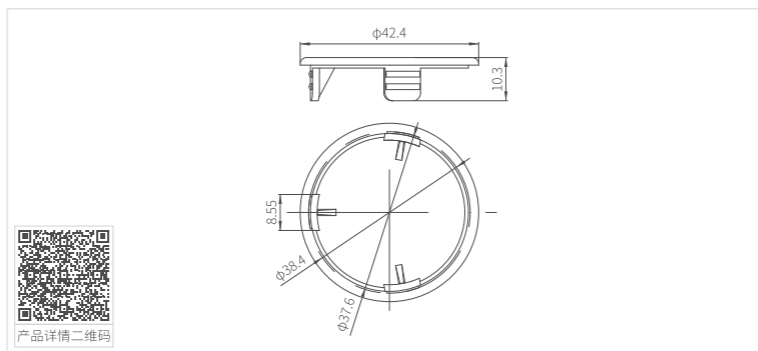

MK-YY-40-02-01 半月牙 MK-YY-40-02-01 Half moon nut



订货号 Item number	MK-YY-40-02-01
产品材质 Material	塑料 Plastic
表面处理 Finish	米黄 Cream-coloured

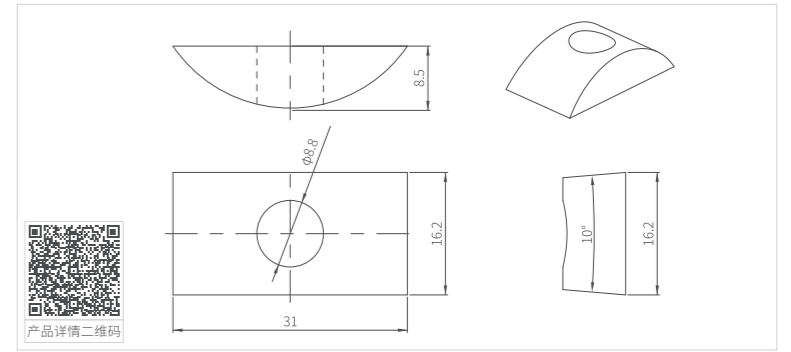

MK-DXL-1C 1寸定向轮 MK-DXL-1C 1 inch directional wheel

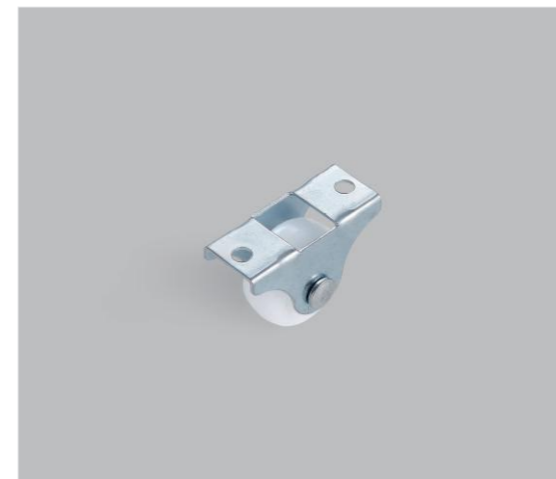

订货号 Item number	MK-DXL-1C
产品材质 Material	铁+塑料 Iron+plastic
表面处理 Finish	白色 White

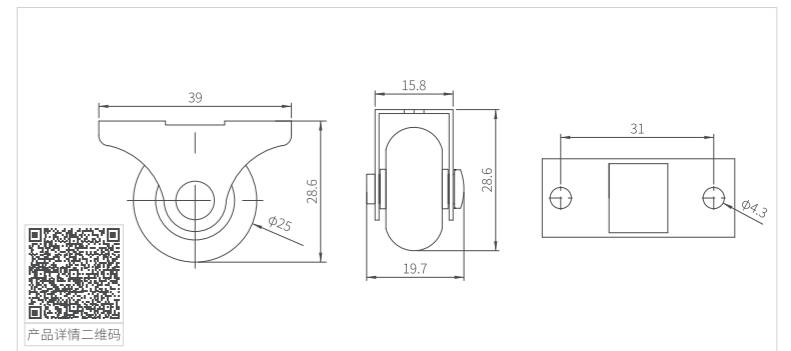

MK-WXL-2C 2寸平板万向轮带刹 MK-WXL-2C 2 inch flat plate universal wheel with brake



订货号 Item number	MK-WXL-2C
产品材质 Material	铁+塑料 Iron+plastic
表面处理 Finish	黑色 Black

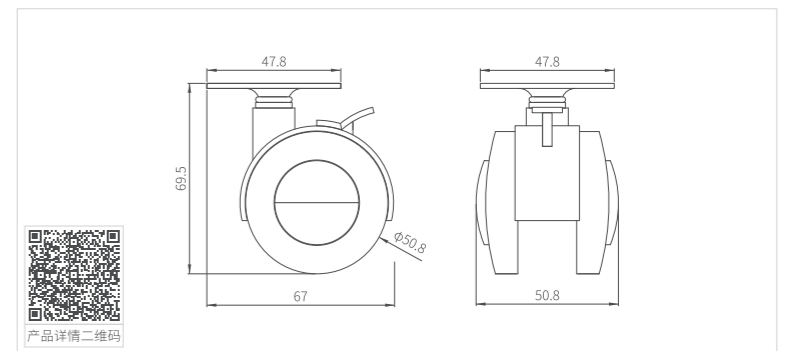

MK-KK-63-57-38 1# 罗马柱卡扣 MK-KK-63-57-38 1# Furniture fixed buckle



订货号 Item number	MK-KK-63-57-38
产品材质 Material	ABS塑料 ABS plastic
表面处理 Finish	黑色 Black

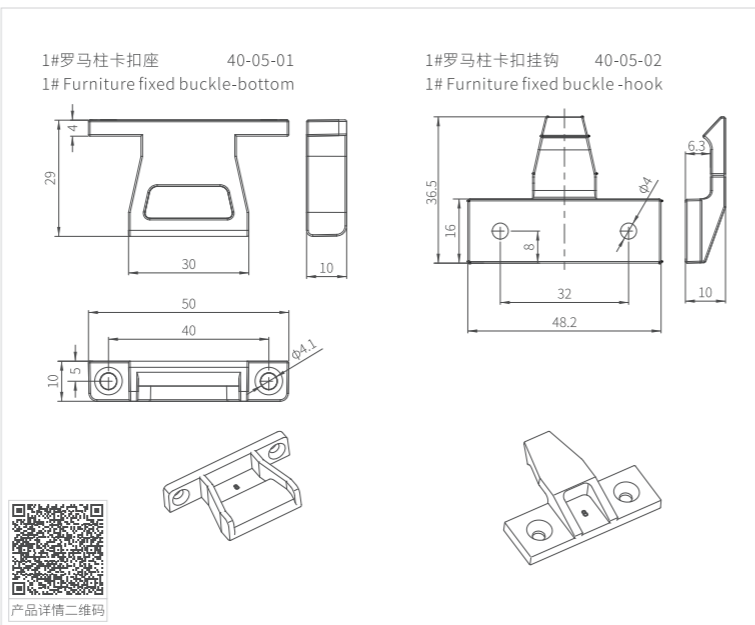

MK-KK-40-05-03 2# 罗马柱卡扣 MK-KK-40-05-03 2# Furniture fixed buckle



订货号 Item number	MK-KK-40-05-03
产品材质 Material	ABS塑料 ABS plastic
表面处理 Finish	黑色 Black

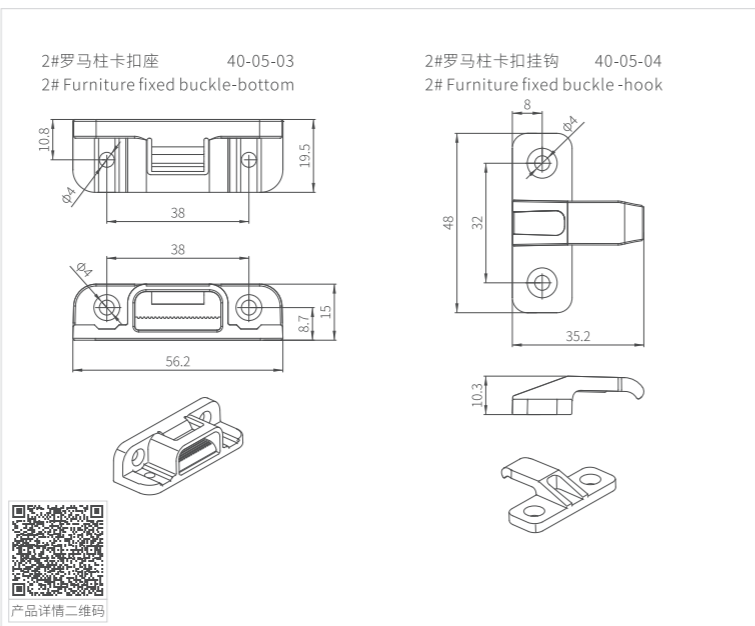

MK-KXJD-1.6 平底空心脚钉 16厘 MK-KXJD-1.6 Furniture glide 16mm



订货号 Item number	MK-KXJD-1.6
产品材质 Material	铁+塑料 Iron+plastic
表面处理 Finish	白色 White

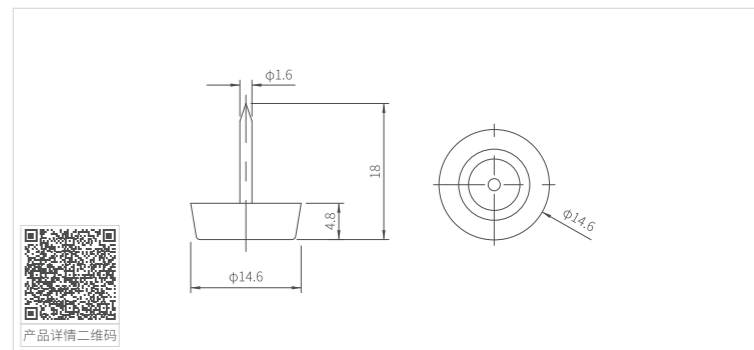

MK-TMJD-16 透明胶垫 MK-TMJD-16 Transparent rubber pad



订货号 Item number	MK-TMJD-16
产品材质 Material	塑料 Plastic
表面处理 Finish	半透明 Transparent

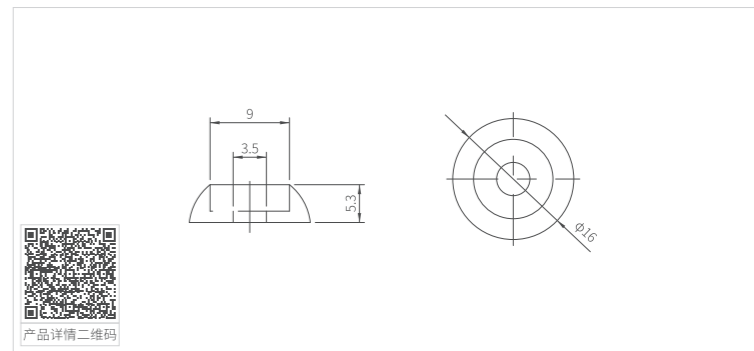

MK-MZD-2.0 毛粘垫 MK-MZD-2.0 Lint pad



订货号 Item number	MK-MZD-2.0
表面处理 Finish	灰色 Gray

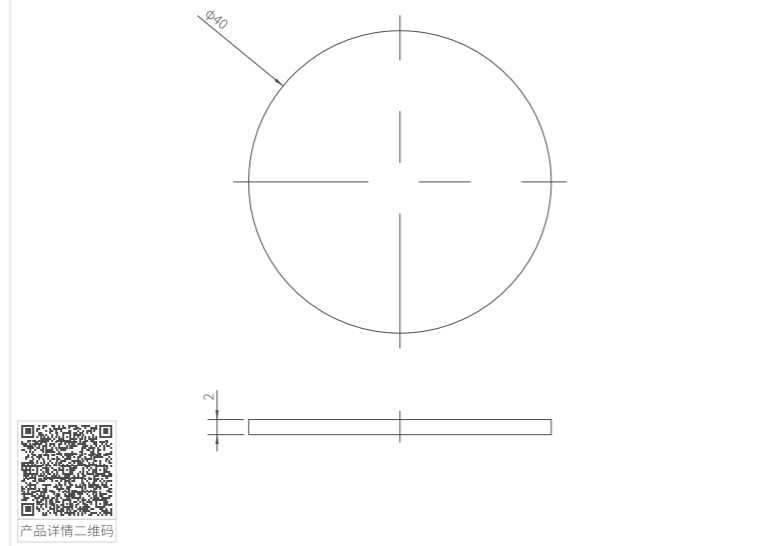
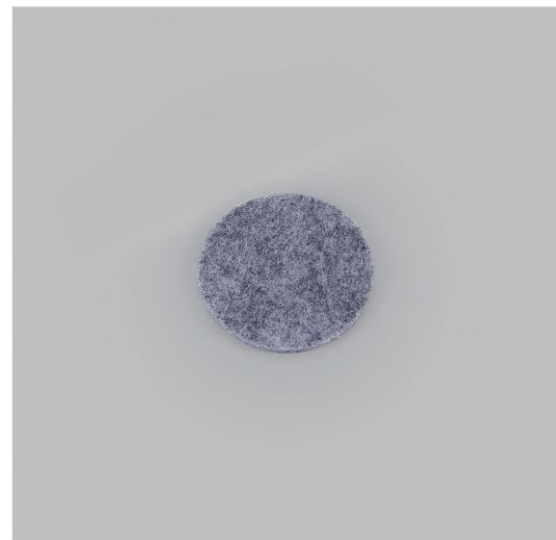
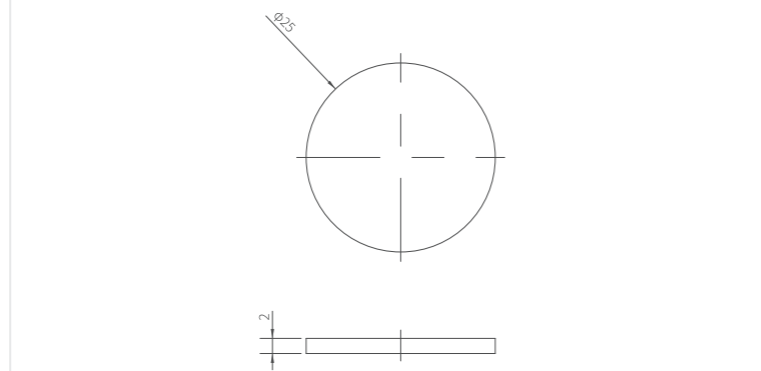
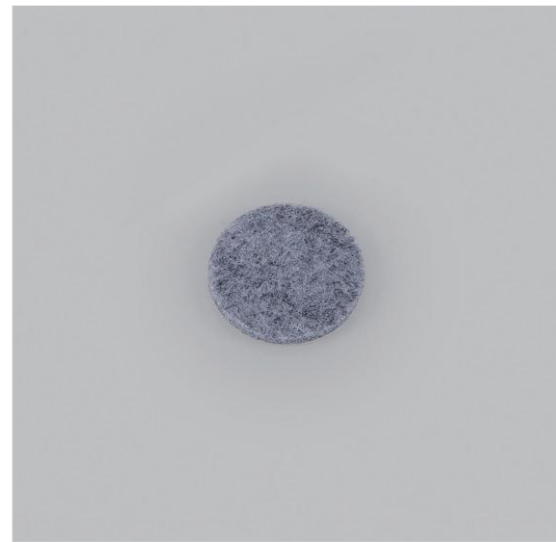
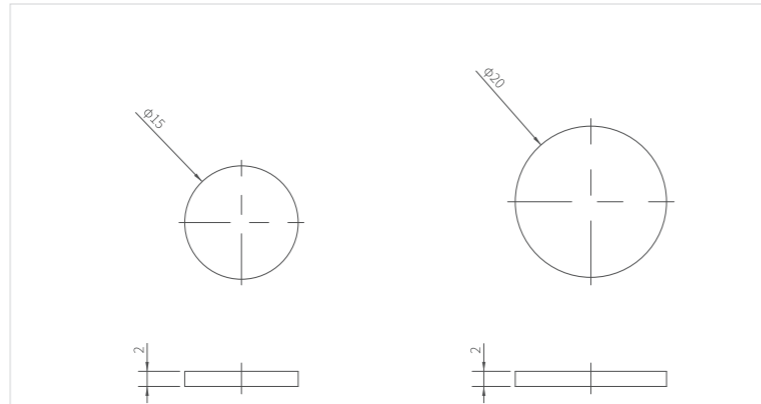

MK-MSZW 直纹木梢 MK-MSZW Wood dowel with vertical stripe



订货号 Item number	MK-MSZW
产品材质 Material	木质 Wood
表面处理 Finish	本色 Natural color

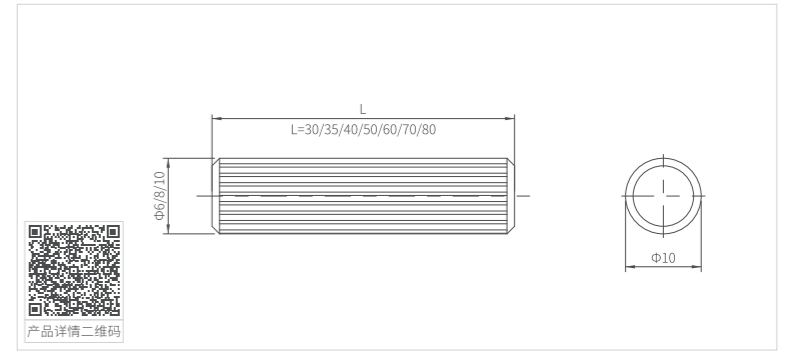

MK-MKXW 斜纹木梢 MK-MKXW Wood dowel with diagonal stripe



订货号 Item number	MK-MKXW
产品材质 Material	木质 Wood
表面处理 Finish	本色 Natural color

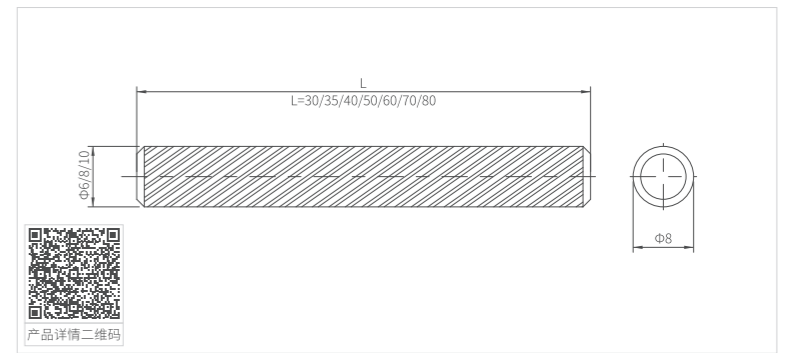

MK-MSXW 斜纹木梢 MK-MSXW Wood dowel with diagonal stripe



订货号 Item number	MK-MSXW
产品材质 Material	木质 Wood
表面处理 Finish	本色 Natural color

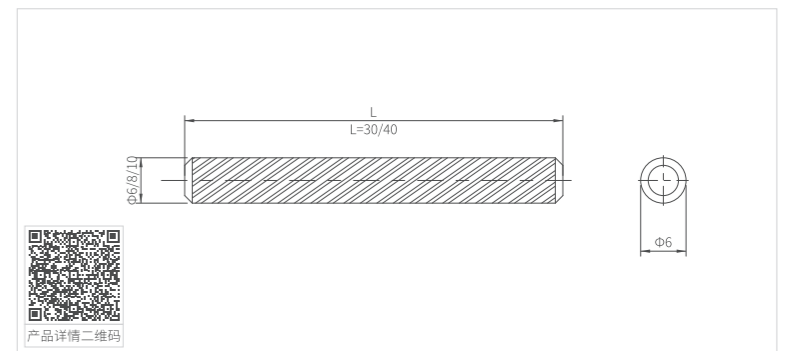

MK-XDL-ZC-10*46 餐桌轴承 MK-XDL-ZC-10*46 Dining table bearing



订货号 Item number	MK-XDL-ZC-10*46
产品材质 Material	碳钢 Carbon steel
表面处理 Finish	蓝白锌 Blue zinc

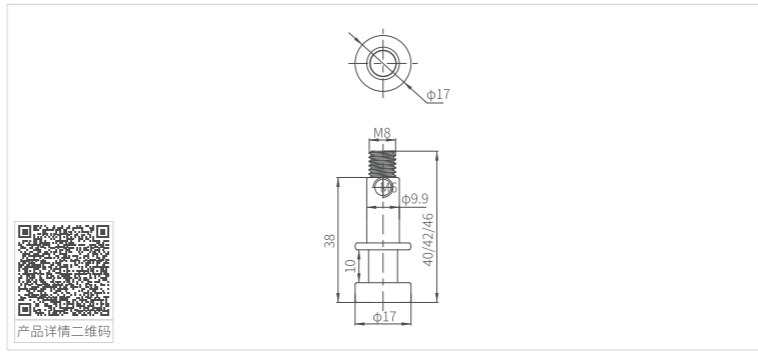

MK-XDL-ZC-10*39 餐桌轴承 MK-XDL-ZC-10*39 Dining table bearing



订货号 Item number	MK-XDL-ZC-10*39
产品材质 Material	碳钢 Carbon steel
表面处理 Finish	蓝白锌 Blue zinc

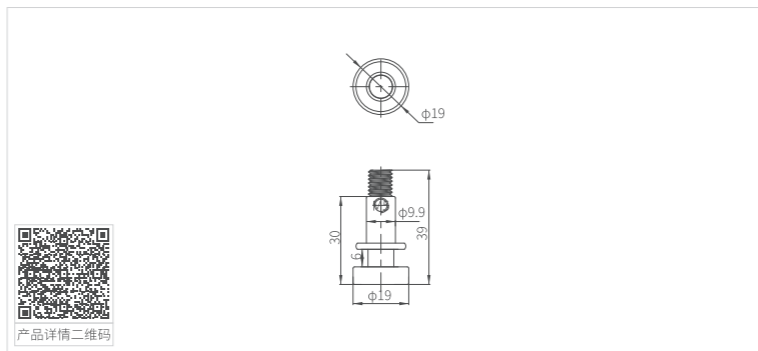



MeiKi明希®

LAZY SUSAN TURNTABLE SERIES
转盘系列

TURN SURPRISE TASTE LIFE
转动惊喜 品味生活

承重强,托起生活百味
稳而顺,畅享美好食光

Strong bearing, holding up life
Steady and smooth, enjoy the good food light

MK-JD-TZP-8C 8寸转盘(铁) MK-JD-TZP-8C 8-inch lazy susan turntable(iron)

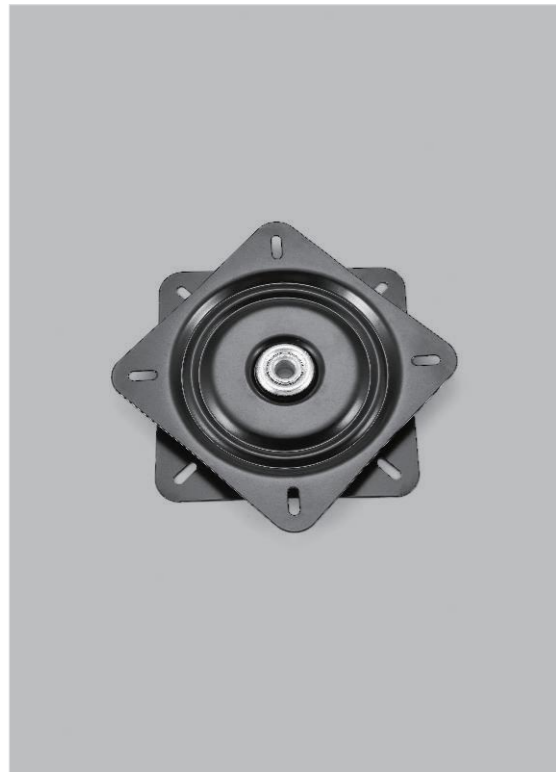

订货号 Item number	MK-JD-TZP-8C
产品材质 Material	冷轧钢 Cold rolled steel
表面处理 Finish	黑色 Black

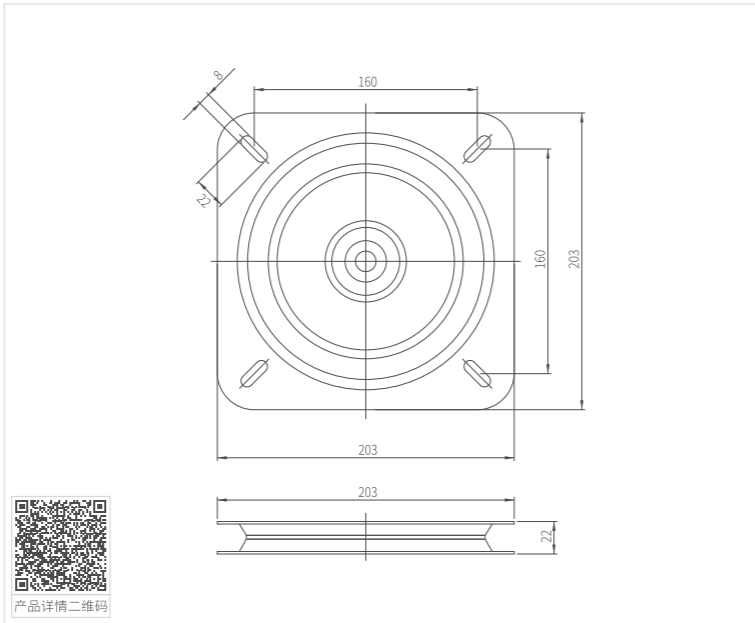

MK-RL-NZP-400C 铝转盘16寸 MK-RL-NZP-400C 16-inch lazy susan turntable(aluminium)

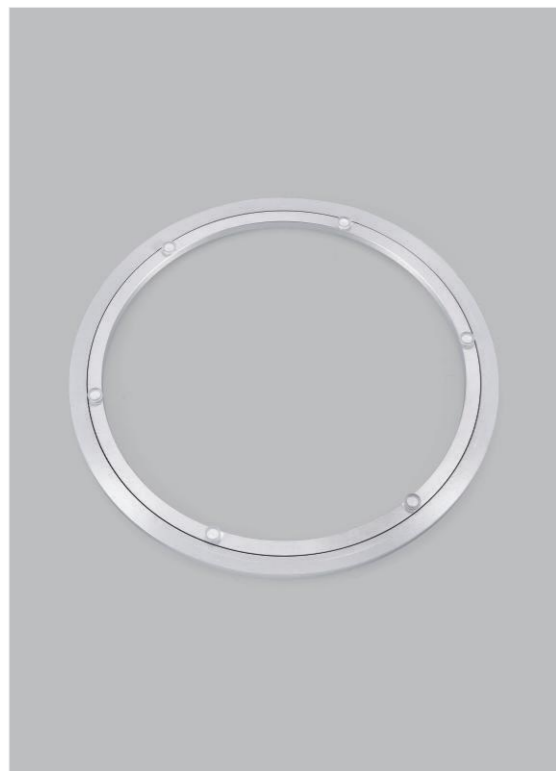

订货号 Item number	MK-RL-NZP-400C
产品材质 Material	铝 Aluminium
表面处理 Finish	本色 Natural color

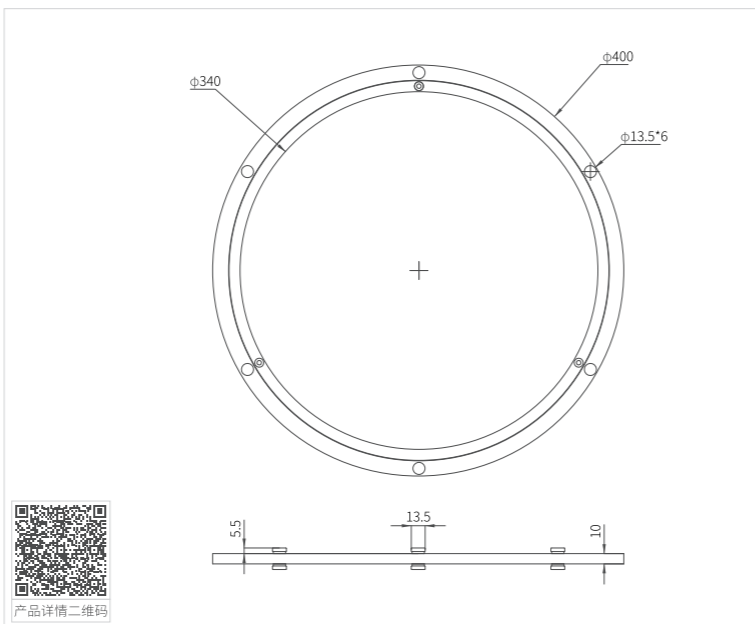

Note:

